

# reducing WAY-207024 dihydrochloride off-target effects in experiments

**Author:** BenchChem Technical Support Team. **Date:** December 2025

## Compound of Interest

Compound Name: WAY-207024 dihydrochloride

Cat. No.: B10768963

[Get Quote](#)

## Technical Support Center: WAY-207024 Dihydrochloride

This technical support center provides troubleshooting guides and frequently asked questions (FAQs) to help researchers, scientists, and drug development professionals mitigate potential off-target effects of **WAY-207024 dihydrochloride** in their experiments.

### Frequently Asked Questions (FAQs)

Q1: What is **WAY-207024 dihydrochloride** and what is its primary mechanism of action?

**WAY-207024 dihydrochloride** is a potent, orally active, non-peptide antagonist of the Gonadotropin-Releasing Hormone (GnRH) receptor.[1][2][3][4] Its primary mechanism of action is to competitively block the GnRH receptor in the anterior pituitary gland. This inhibition prevents the release of luteinizing hormone (LH) and follicle-stimulating hormone (FSH), leading to a reduction in downstream sex hormone production, such as testosterone and estrogen.[5][6]

Q2: What are the known on-target potency values for WAY-207024?

The inhibitory activity of WAY-207024 is typically measured by its half-maximal inhibitory concentration (IC50). The known IC50 values for the GnRH receptor are summarized in the table below.

| Species | IC50 Value (nM) |
|---------|-----------------|
| Human   | 12              |
| Rat     | 71              |

Data sourced from MedKoo Biosciences and Tocris Bioscience.<sup>[2][3]</sup>

Q3: Are there any known specific off-target interactions for WAY-207024?

Currently, there is limited publicly available information detailing a comprehensive off-target profile for **WAY-207024 dihydrochloride**. As with many small molecule inhibitors, there is a potential for interactions with other cellular targets, particularly at higher concentrations. The primary side effects discussed in the literature for non-peptide GnRH antagonists are generally related to the intended hypoestrogenic effects resulting from on-target activity.<sup>[4][5]</sup>

Researchers should therefore empirically determine and validate the specificity of WAY-207024 in their experimental model.

Q4: What general types of off-target effects can be anticipated with small molecule inhibitors like WAY-207024?

While specific off-targets for WAY-207024 are not well-documented, general off-target effects for small molecules can include:

- Interaction with related receptors: Binding to other G-protein coupled receptors (GPCRs) with structural similarities to the GnRH receptor.
- Kinase inhibition: Many small molecules can interact with the ATP-binding pocket of protein kinases.
- Ion channel modulation: Direct or indirect effects on the function of various ion channels.
- Enzyme inhibition: Unintended inhibition of metabolic enzymes or other signaling proteins.
- Chemical reactivity: Some compounds can be chemically reactive, leading to non-specific interactions with cellular components.

# Troubleshooting Guide: Investigating and Mitigating Off-Target Effects

This guide provides a systematic approach to identifying and minimizing potential off-target effects of WAY-207024 in your experiments.

| Issue  | Potential Cause  | Recommended Action  |
|--|--|---|
| <p>Inconsistent or unexpected experimental results.</p>    | <p>Off-target effects of WAY-207024 at the concentration used.</p>                                 | <p>1. Confirm On-Target Engagement: Verify that WAY-207024 is inhibiting the GnRH receptor as expected in your system. See the "On-Target Engagement Assay" protocol below.<br/>                 2. Perform a Dose-Response Curve: Determine the minimal effective concentration of WAY-207024 to minimize the risk of off-target effects at higher concentrations.<br/>                 3. Use a Negative Control: Employ a structurally similar but biologically inactive analog of WAY-207024. If the inactive analog produces the same phenotype, an off-target effect is likely.</p> |
| <p>Observed phenotype is not rescued by GnRH addition.</p> | <p>The phenotype may be due to an off-target effect independent of the GnRH signaling pathway.</p> | <p>1. Genetic Knockdown of the Target: Use siRNA or shRNA to specifically knockdown the GnRH receptor. If this reproduces the phenotype observed with WAY-207024, it confirms the effect is on-target.<br/>                 2. Use an Orthogonal Antagonist: Employ a structurally different GnRH antagonist. If it produces the same phenotype, it strengthens the evidence for an on-target effect.</p>   |

Cellular toxicity or other unexpected phenotypes at high concentrations.

Off-target interactions or non-specific chemical effects.

1. Perform a Cell Viability Assay: Assess the cytotoxicity of WAY-207024 in your cell model to identify a non-toxic working concentration range. 2. In Silico Off-Target Prediction: Use computational tools to predict potential off-target interactions based on the chemical structure of WAY-207024. This can provide a list of candidate off-targets for further investigation. 3. Broad-Spectrum Off-Target Screening: If resources permit, consider a commercial off-target screening service that tests the compound against a panel of common off-target proteins (e.g., kinases, GPCRs, ion channels).<sup>[7][8][9]</sup>

## Experimental Protocols

### Protocol 1: On-Target Engagement Assay - Measurement of Testosterone Suppression (In Vivo)

This protocol is adapted for a rodent model to confirm the biological activity of WAY-207024 on the hypothalamic-pituitary-gonadal axis.

Objective: To confirm that WAY-207024 is effectively antagonizing the GnRH receptor in vivo by measuring the downstream effect on serum testosterone levels.

Materials:

- **WAY-207024 dihydrochloride**

- Vehicle control (e.g., sterile water or as recommended by the manufacturer)
- Adult male rodents (e.g., Sprague-Dawley rats)
- Blood collection supplies
- ELISA kit for testosterone measurement

#### Procedure:

- **Animal Acclimation:** Acclimate animals to the housing conditions for at least one week prior to the experiment.
- **Dosing:** Prepare a solution of WAY-207024 in the appropriate vehicle. Administer the compound to the treatment group via the desired route (e.g., oral gavage). Administer vehicle only to the control group.
- **Blood Collection:** Collect blood samples at predetermined time points post-administration (e.g., 0, 2, 4, 8, 24 hours).
- **Serum Separation:** Allow blood to clot and then centrifuge to separate the serum. Store serum at -80°C until analysis.
- **Testosterone Measurement:** Quantify testosterone levels in the serum samples using a commercial ELISA kit according to the manufacturer's instructions.
- **Data Analysis:** Compare testosterone levels between the WAY-207024-treated group and the vehicle control group. A significant reduction in testosterone levels in the treated group confirms on-target engagement.

## Protocol 2: Negative Control Experiment - Inactive Analog

**Objective:** To differentiate between on-target and off-target effects by using a structurally similar but biologically inactive analog of WAY-207024.

**Materials:**

- **WAY-207024 dihydrochloride**
- Inactive structural analog of WAY-207024 (if available)
- Vehicle control
- Your experimental system (e.g., cell culture)
- Assay to measure your phenotype of interest

Procedure:

- Treatment: Treat your experimental system with equimolar concentrations of:
  - Vehicle control
  - WAY-207024
  - Inactive analog
- Incubation: Incubate for the desired duration of your experiment.
- Phenotypic Analysis: Measure the phenotype of interest using your established assay.
- Data Interpretation:
  - On-target effect: The phenotype is observed only with WAY-207024 and not with the inactive analog or vehicle.
  - Off-target effect: The phenotype is observed with both WAY-207024 and the inactive analog.

## Protocol 3: Genetic Knockdown of GnRH Receptor

Objective: To confirm that the observed phenotype is dependent on the GnRH receptor.

Materials:

- siRNA or shRNA targeting the GnRH receptor

- Non-targeting (scrambled) control siRNA/shRNA
- Transfection reagent
- Your experimental cell line
- WAY-207024
- Assay to measure your phenotype of interest
- Western blot or qPCR reagents to confirm knockdown

#### Procedure:

- **Transfection:** Transfect your cells with either the GnRH receptor-targeting siRNA/shRNA or the non-targeting control.
- **Knockdown Confirmation:** After 48-72 hours, confirm the knockdown of the GnRH receptor at the protein (Western blot) or mRNA (qPCR) level.
- **WAY-207024 Treatment:** Treat the knockdown and control cells with WAY-207024 or vehicle.
- **Phenotypic Analysis:** Measure the phenotype of interest.
- **Data Interpretation:**
  - If the phenotype caused by WAY-207024 is absent or significantly reduced in the GnRH receptor knockdown cells compared to the control cells, this strongly suggests the effect is on-target.
  - If the phenotype persists in the knockdown cells, it is likely an off-target effect.

## Visualizations

### Signaling Pathway



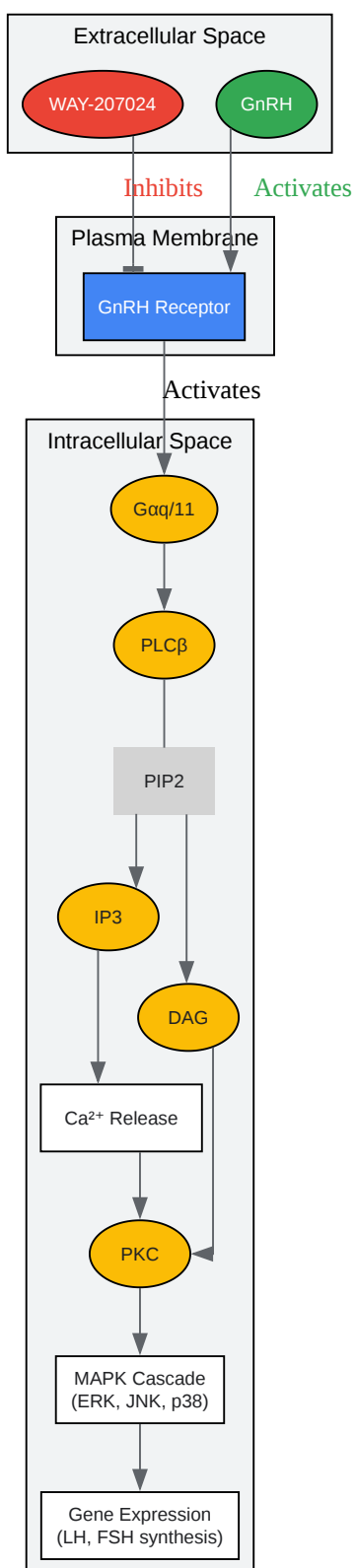

[Click to download full resolution via product page](#)

Caption: Simplified GnRH Receptor Signaling Pathway.

## Experimental Workflow

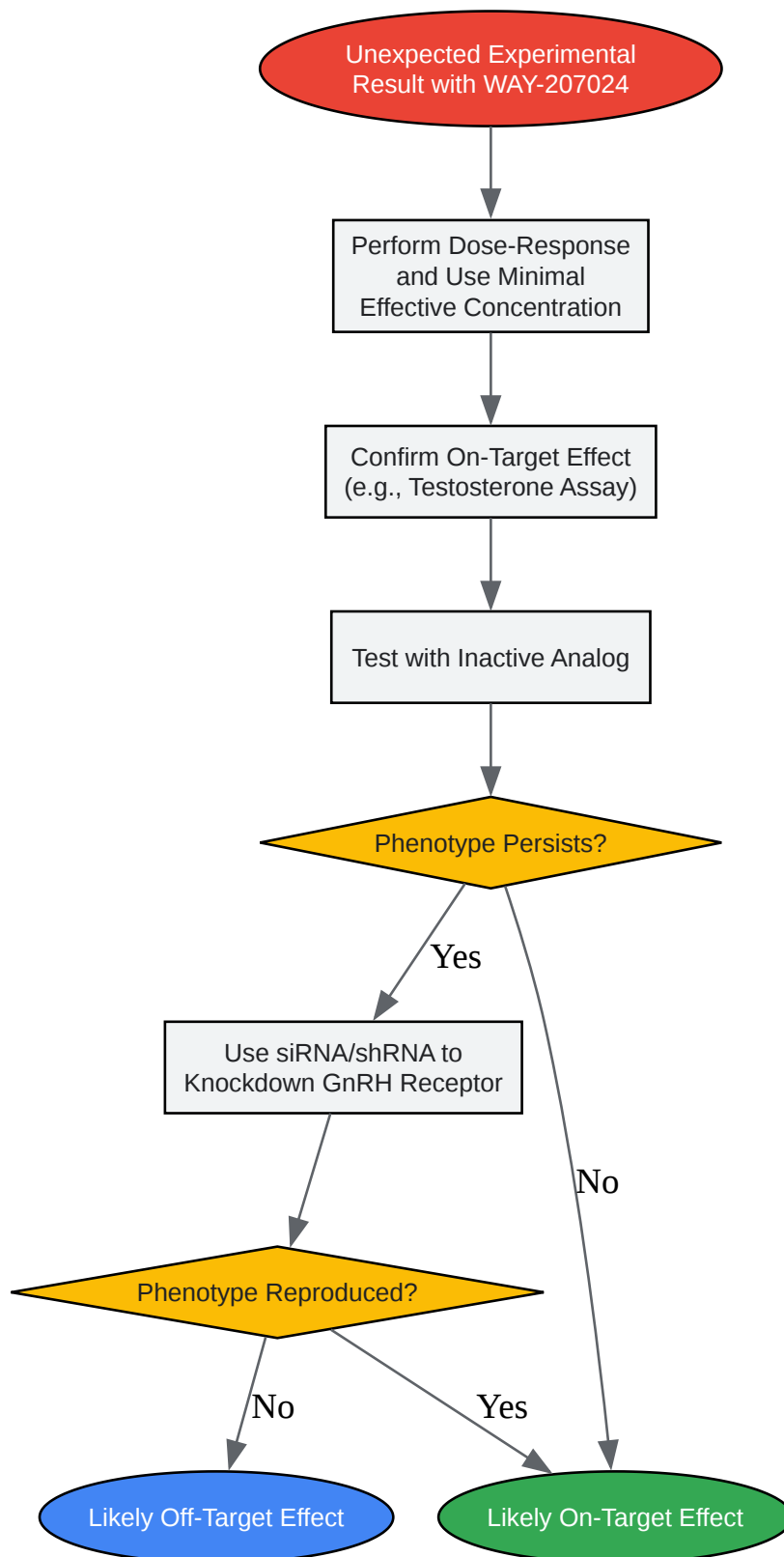

[Click to download full resolution via product page](#)

Caption: Workflow for troubleshooting off-target effects.

## Logical Relationship

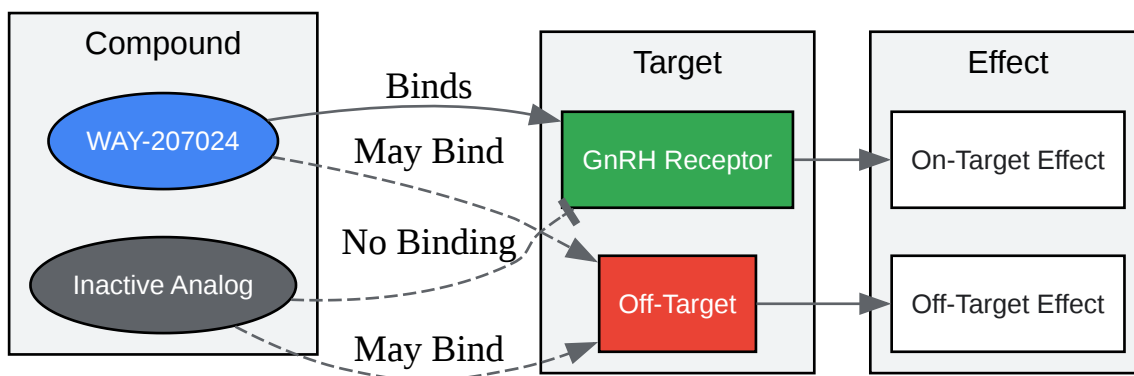

[Click to download full resolution via product page](#)

Caption: Logical relationship of on- and off-target effects.

### Need Custom Synthesis?

BenchChem offers custom synthesis for rare earth carbides and specific isotopic labeling.

Email: [info@benchchem.com](mailto:info@benchchem.com) or [Request Quote Online](#).

## References

- 1. What are the therapeutic candidates targeting GnRHR? [synapse.patsnap.com]
- 2. An integrative epigenome-based strategy for unbiased functional profiling of clinical kinase inhibitors | Molecular Systems Biology [link.springer.com]
- 3. A Probe-Based Target Engagement Assay for Kinases in Live Cells - PMC [pmc.ncbi.nlm.nih.gov]
- 4. Gonadotropin-Releasing Hormone Antagonists—A New Hope in Endometriosis Treatment? - PMC [pmc.ncbi.nlm.nih.gov]
- 5. Current approaches to overcome the side effects of GnRH analogs in the treatment of patients with uterine fibroids - PMC [pmc.ncbi.nlm.nih.gov]
- 6. Recent Development of Non-Peptide GnRH Antagonists - PMC [pmc.ncbi.nlm.nih.gov]

- 7. criver.com [criver.com]
- 8. Off-Target Effects Analysis | Creative Diagnostics [creative-diagnostics.com]
- 9. Off-Target Profiling - Creative Biolabs [creative-biolabs.com]
- To cite this document: BenchChem. [reducing WAY-207024 dihydrochloride off-target effects in experiments]. BenchChem, [2025]. [Online PDF]. Available at: [https://www.benchchem.com/product/b10768963#reducing-way-207024-dihydrochloride-off-target-effects-in-experiments]

---

### Disclaimer & Data Validity:

The information provided in this document is for Research Use Only (RUO) and is strictly not intended for diagnostic or therapeutic procedures. While BenchChem strives to provide accurate protocols, we make no warranties, express or implied, regarding the fitness of this product for every specific experimental setup.

**Technical Support:** The protocols provided are for reference purposes. Unsure if this reagent suits your experiment? [[Contact our Ph.D. Support Team for a compatibility check](#)]

**Need Industrial/Bulk Grade?** [Request Custom Synthesis Quote](#)

## BenchChem

Our mission is to be the trusted global source of essential and advanced chemicals, empowering scientists and researchers to drive progress in science and industry.

### Contact

Address: 3281 E Guasti Rd  
Ontario, CA 91761, United States  
Phone: (601) 213-4426  
Email: [info@benchchem.com](mailto:info@benchchem.com)