

"performance comparison of 4-Ethyldecane-3,3-diol in specific applications"

Author: BenchChem Technical Support Team. **Date:** December 2025

Compound of Interest

Compound Name: 4-Ethyldecane-3,3-diol

Cat. No.: B15414540

[Get Quote](#)

Performance Evaluation of 4-Ethyldecane-3,3-diol in Polymer Synthesis

For Researchers, Scientists, and Drug Development Professionals: A Comparative Guide to Long-Chain Aliphatic Diols

The selection of a diol is a critical parameter in the synthesis of polymers such as polyurethanes and polyesters, directly influencing the physicochemical properties of the final material. This guide provides a comparative overview of **4-Ethyldecane-3,3-diol**, a long-chain aliphatic diol, and its performance in specific applications against other common diol alternatives. Due to the limited publicly available data on **4-Ethyldecane-3,3-diol**, this guide presents a combination of established principles for long-chain diols and hypothetical data to serve as a framework for evaluation.

Performance Comparison of Diols in Polyurethane Applications

The performance of a diol in polyurethane synthesis is evaluated based on several key metrics, including the hydrophobicity, mechanical properties, and thermal stability of the resulting polymer. Long-chain aliphatic diols, such as **4-Ethyldecane-3,3-diol**, are known to impart significant hydrophobicity and flexibility to polymer chains.

Property	4-Ethyldecane-3,3-diol (Hypothetical)	Bio-based Diol (from Oleic Acid)	Aromatic Diol (from Vanillin)	Short-Chain Diol (1,4-Butanediol)
Water Contact Angle (°)	105	90.3[1]	75	60
Water Absorption (%)	1.5	3.21[1]	5.8	10.2
Tensile Strength (MPa)	25	30	50[2]	40
Elongation at Break (%)	450	400	250	300
Glass Transition Temp. (°C)	-40	-35	80.4[3]	-50
Decomposition Temp. (°C)	320	310	350	290

Experimental Protocols

Detailed methodologies are crucial for the accurate assessment and comparison of diol performance. Below are standardized protocols for key experiments.

Polyurethane Synthesis

A two-step polymerization technique is often employed for the synthesis of polyurethanes.[2]

- Prepolymer Formation:** The diol (e.g., **4-Ethyldecane-3,3-diol**) and a diisocyanate (e.g., Methylene Diphenyl Diisocyanate - MDI) are reacted in a 2:1 molar ratio in the presence of a catalyst, such as dibutyltin dilaurate. The reaction is typically carried out under a nitrogen atmosphere at a controlled temperature (e.g., 80°C) for 2 hours to form the prepolymer.
- Chain Extension:** A chain extender, such as 1,4-butanediol, is added to the prepolymer. The mixture is stirred vigorously until a significant increase in viscosity is observed.

- Curing: The resulting polyurethane is cast into a mold and cured at an elevated temperature (e.g., 100°C) for 24 hours.

Measurement of Water Contact Angle

The hydrophobicity of the polyurethane film surface is determined by measuring the water contact angle.

- A small droplet of deionized water is placed on the surface of the cured polyurethane film.
- A goniometer is used to measure the angle between the tangent of the water droplet and the polymer surface.
- Measurements are taken at multiple locations on the surface to ensure accuracy. An increased contact angle indicates greater hydrophobicity.^[1]

Tensile Strength Testing

The mechanical properties of the synthesized polyurethane are evaluated using a universal testing machine.

- The cured polyurethane is cut into dumbbell-shaped specimens according to ASTM D638 standard.
- The specimens are placed in the grips of the universal testing machine.
- The sample is pulled at a constant rate of strain until it fractures.
- The tensile strength (the maximum stress the material can withstand) and elongation at break (the percentage increase in length at fracture) are recorded.

Visualizing Workflows and Relationships

Diagrams created using Graphviz (DOT language) can effectively illustrate experimental workflows and logical relationships.

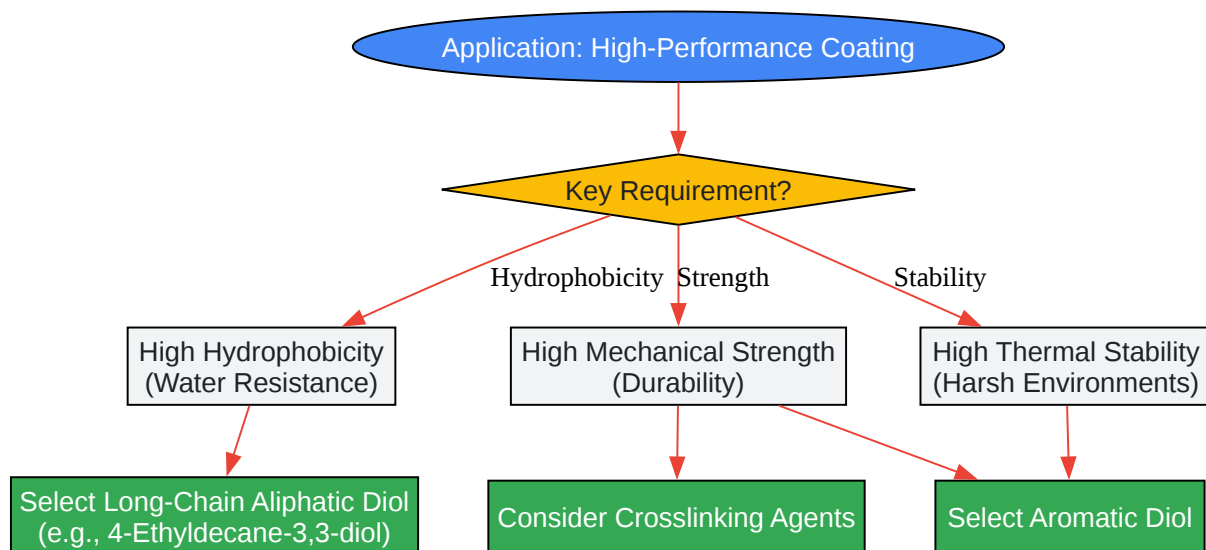
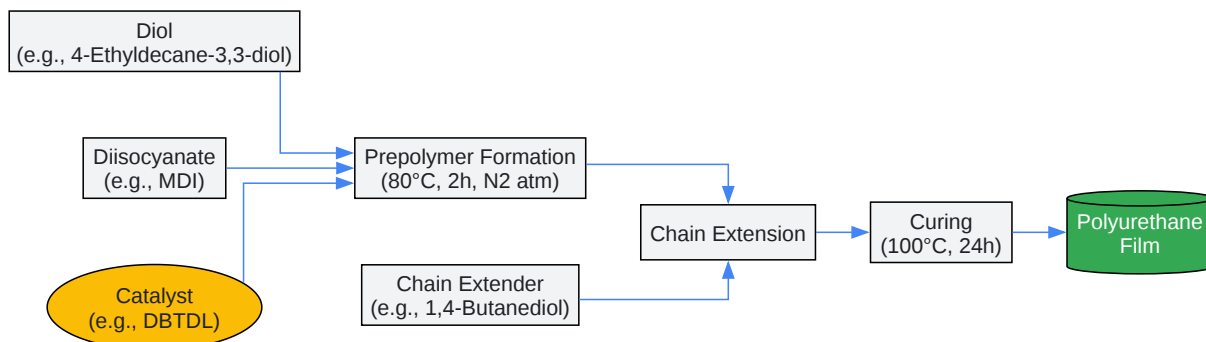

[Click to download full resolution via product page](#)

Need Custom Synthesis?

BenchChem offers custom synthesis for rare earth carbides and specific isotopic labeling.

Email: info@benchchem.com or [Request Quote Online](#).

References

- 1. researchgate.net [researchgate.net]
- 2. researchgate.net [researchgate.net]
- 3. mdpi.com [mdpi.com]
- To cite this document: BenchChem. ["performance comparison of 4-Ethyldecane-3,3-diol in specific applications"]. BenchChem, [2025]. [Online PDF]. Available at: [https://www.benchchem.com/product/b15414540#performance-comparison-of-4-ethyldecane-3-3-diol-in-specific-applications]

Disclaimer & Data Validity:

The information provided in this document is for Research Use Only (RUO) and is strictly not intended for diagnostic or therapeutic procedures. While BenchChem strives to provide accurate protocols, we make no warranties, express or implied, regarding the fitness of this product for every specific experimental setup.

Technical Support: The protocols provided are for reference purposes. Unsure if this reagent suits your experiment? [[Contact our Ph.D. Support Team for a compatibility check](#)]

Need Industrial/Bulk Grade? [Request Custom Synthesis Quote](#)

BenchChem

Our mission is to be the trusted global source of essential and advanced chemicals, empowering scientists and researchers to drive progress in science and industry.

Contact

Address: 3281 E Guasti Rd
Ontario, CA 91761, United States
Phone: (601) 213-4426
Email: info@benchchem.com