

optimizing UV irradiation time for 8-Azido-cADPR experiments

Author: BenchChem Technical Support Team. **Date:** December 2025

Compound of Interest

Compound Name: 8-Azido-cADPR

Cat. No.: B12412492

[Get Quote](#)

Technical Support Center: 8-Azido-cADPR Experiments

This technical support center provides troubleshooting guides and frequently asked questions (FAQs) to assist researchers, scientists, and drug development professionals in optimizing UV irradiation time for **8-Azido-cADPR** (8-N₃-cADPR) photoaffinity labeling experiments.

Frequently Asked Questions (FAQs)

Q1: What is the optimal UV wavelength for activating **8-Azido-cADPR**?

A1: The optimal UV wavelength for activating aryl azides like **8-Azido-cADPR** is typically in the range of 254-265 nm. However, some studies have successfully used longer wavelengths, such as 350 nm, which can sometimes reduce sample damage. It is recommended to consult the manufacturer's specifications for your specific **8-Azido-cADPR** reagent.

Q2: How long should I irradiate my sample?

A2: The ideal irradiation time is a critical parameter that requires optimization. It can range from a few minutes to over 30 minutes.^{[1][2]} Factors influencing the optimal time include UV lamp intensity, the distance of the sample from the UV source, and the concentration of the **8-Azido-cADPR** probe. A time-course experiment is highly recommended to determine the best balance between labeling efficiency and potential sample degradation.

Q3: What are common causes of low or no labeling?

A3: Several factors can contribute to poor labeling efficiency:

- Insufficient UV exposure: The irradiation time may be too short, or the UV lamp intensity may be too low.
- Quenching of the nitrene intermediate: Buffers containing primary amines (e.g., Tris) or reducing agents (e.g., DTT, β -mercaptoethanol) can react with the photogenerated nitrene and prevent labeling of the target protein.[2]
- Low probe concentration: The concentration of **8-Azido-cADPR** may be insufficient to achieve detectable labeling.
- Inactive probe: Ensure the **8-Azido-cADPR** has been stored correctly and has not been prematurely exposed to light.

Q4: How can I be sure the labeling is specific to the cADPR binding site?

A4: To demonstrate specificity, it is crucial to perform competition experiments.[3][4] This involves pre-incubating the sample with an excess of non-photoreactive cADPR before adding **8-Azido-cADPR** and irradiating. A significant reduction in labeling in the presence of the competitor indicates specific binding.

Troubleshooting Guide

Issue	Potential Cause	Recommended Solution
No or weak signal	Insufficient UV irradiation	Increase irradiation time incrementally (e.g., 5, 10, 20 minutes) and/or decrease the distance to the UV source.
Buffer interference	Use buffers without primary amines (e.g., HEPES, PBS) and exclude reducing agents during irradiation.[2]	
Probe concentration too low	Increase the concentration of 8-Azido-cADPR.	
Inactive probe	Use a fresh stock of 8-Azido-cADPR and always protect it from light before the irradiation step.	
High background/non-specific labeling	Excessive UV irradiation	Reduce the irradiation time. Over-irradiation can lead to non-specific crosslinking.
Probe concentration too high	Decrease the concentration of 8-Azido-cADPR.	
Aggregation of probe or protein	Centrifuge the sample before irradiation to remove any aggregates.	
Sample degradation	UV-induced damage	Use a longer wavelength UV source (e.g., 350 nm) if possible, or shorten the irradiation time. Keep the sample on ice during irradiation.[2]
Protease activity	Add protease inhibitors to your sample preparation.	

Experimental Protocols

Protocol 1: Optimization of UV Irradiation Time

This protocol outlines a method to determine the optimal UV irradiation time for your specific experimental setup.

- **Sample Preparation:** Prepare multiple identical samples containing your target protein (e.g., cell lysate, purified protein) and **8-Azido-cADPR** in a suitable buffer (e.g., HEPES or PBS). Include a no-UV control sample that is handled identically but not exposed to UV light.
- **UV Irradiation:**
 - Place the samples on ice at a fixed distance from the UV lamp.
 - Expose each sample to UV light (e.g., 254 nm) for different durations (e.g., 0, 1, 5, 10, 20, 30 minutes).
- **Analysis:**
 - Analyze the samples by SDS-PAGE and subsequent autoradiography (if using a radiolabeled probe) or western blotting with an antibody against the target protein or a tag.
 - The optimal irradiation time is the one that gives the strongest signal for the target protein with the lowest background.

Protocol 2: Competition Assay for Specificity

- **Sample Preparation:** Prepare two sets of samples.
 - **Set A (Competition):** Pre-incubate your protein sample with a 100-fold molar excess of unlabeled cADPR for 15-30 minutes at room temperature. Then, add the **8-Azido-cADPR**.
 - **Set B (Control):** Prepare the sample with **8-Azido-cADPR** without the excess unlabeled cADPR.
- **UV Irradiation:** Irradiate both sets of samples using the optimized time determined in Protocol 1.

- Analysis: Analyze the samples by SDS-PAGE. A significant decrease in the band intensity in Set A compared to Set B indicates specific labeling of the cADPR binding site.

Data Presentation

Table 1: Example Time-Course Experiment Data

Irradiation Time (minutes)	Target Protein Signal Intensity (Arbitrary Units)	Background Signal Intensity (Arbitrary Units)	Signal-to-Noise Ratio
0 (No UV)	0	5	0
1	50	10	5
5	150	25	6
10	250	50	5
20	275	150	1.8
30	280	250	1.1

In this example, 5-10 minutes would be the optimal irradiation time.

Visualizations

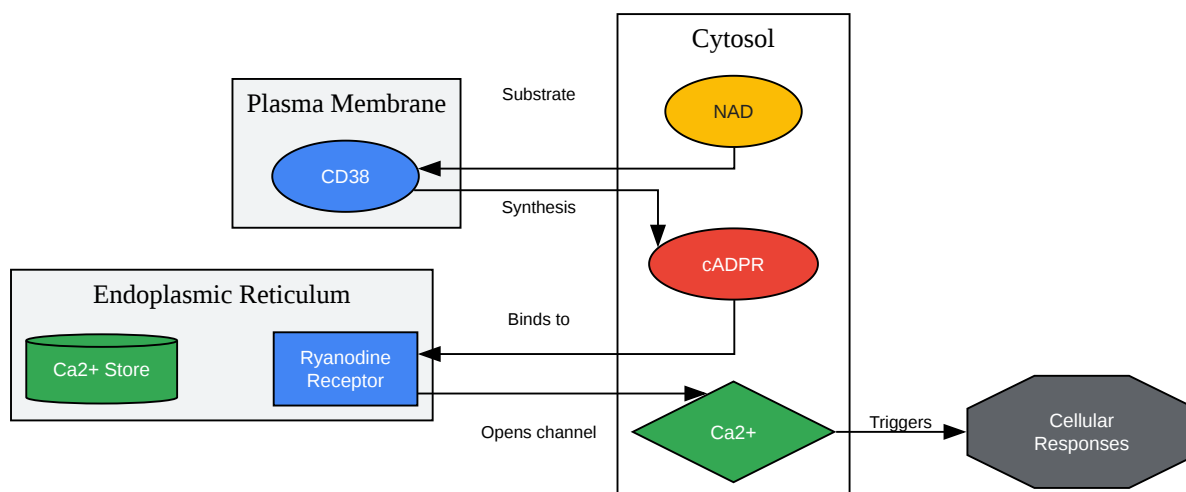

[Click to download full resolution via product page](#)

Caption: cADPR Signaling Pathway.

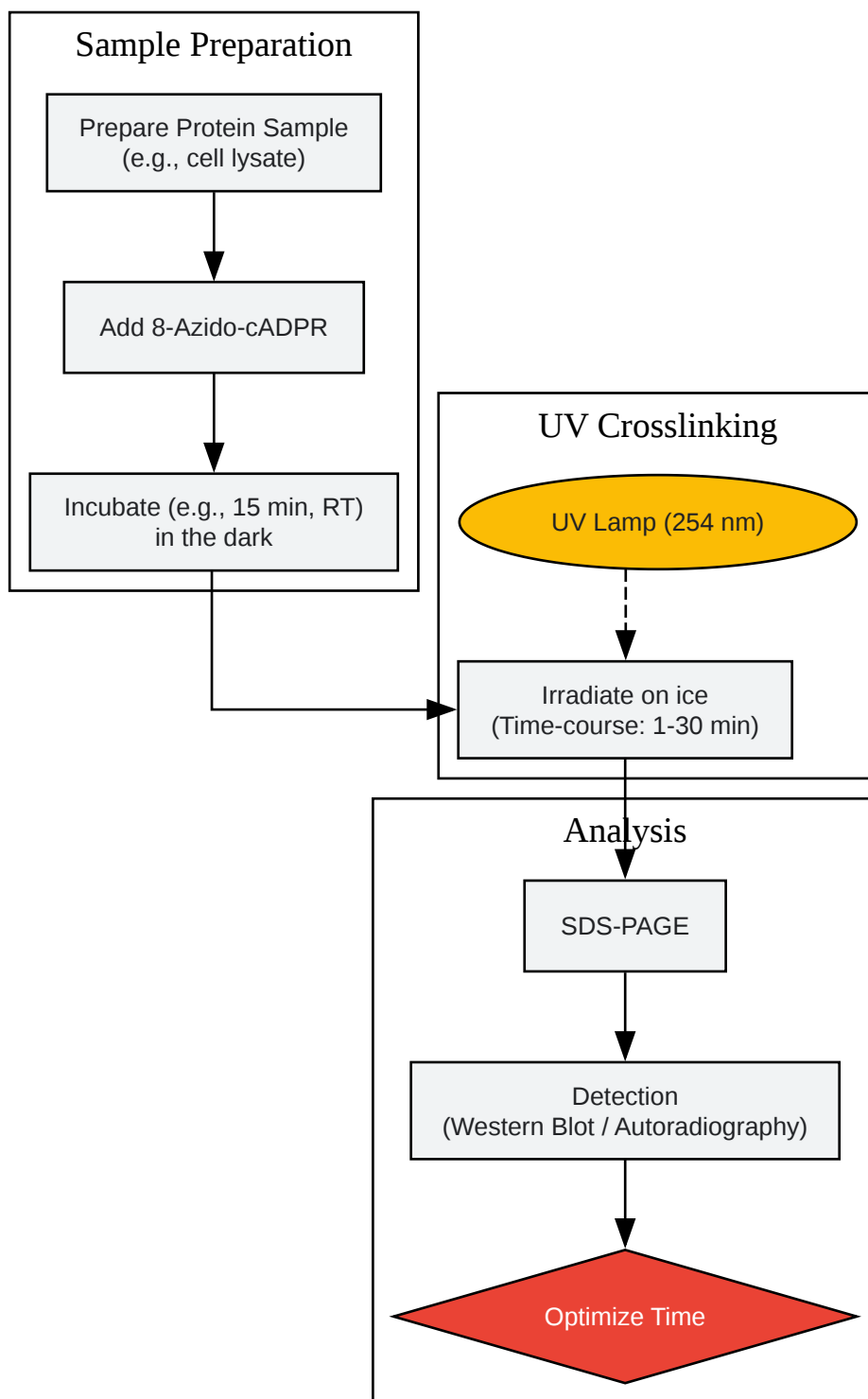

[Click to download full resolution via product page](#)

Caption: Experimental Workflow for UV Crosslinking.

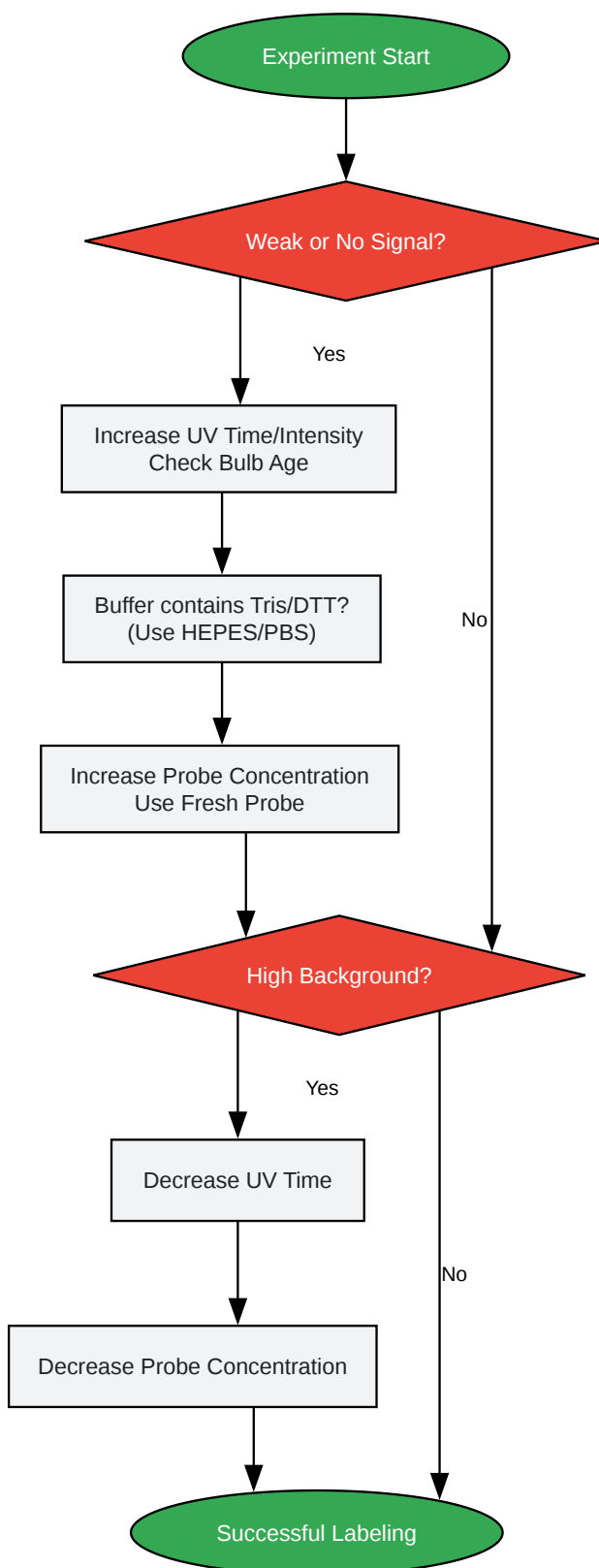

[Click to download full resolution via product page](#)

Caption: Troubleshooting Logic Flowchart.

Need Custom Synthesis?

BenchChem offers custom synthesis for rare earth carbides and specific isotopic labeling.

Email: info@benchchem.com or [Request Quote Online](#).

References

- 1. Photoaffinity labeling of nucleotide binding sites with 8-azidopurine analogs: techniques and applications - PubMed [pubmed.ncbi.nlm.nih.gov]
- 2. Protocol for clickable photoaffinity labeling and quantitative chemical proteomics - PubMed [pubmed.ncbi.nlm.nih.gov]
- 3. Protocol for clickable photoaffinity labeling and quantitative chemical proteomics - PMC [pubmed.ncbi.nlm.nih.gov]
- 4. Utilization of Photoaffinity Labeling to Investigate Binding of Microtubule Stabilizing Agents to P-glycoprotein and β -Tubulin - PMC [pubmed.ncbi.nlm.nih.gov]
- To cite this document: BenchChem. [optimizing UV irradiation time for 8-Azido-cADPR experiments]. BenchChem, [2025]. [Online PDF]. Available at: [<https://www.benchchem.com/product/b12412492#optimizing-uv-irradiation-time-for-8-azido-cadpr-experiments>]

Disclaimer & Data Validity:

The information provided in this document is for Research Use Only (RUO) and is strictly not intended for diagnostic or therapeutic procedures. While BenchChem strives to provide accurate protocols, we make no warranties, express or implied, regarding the fitness of this product for every specific experimental setup.

Technical Support: The protocols provided are for reference purposes. Unsure if this reagent suits your experiment? [[Contact our Ph.D. Support Team for a compatibility check](#)]

Need Industrial/Bulk Grade? [Request Custom Synthesis Quote](#)

BenchChem

Our mission is to be the trusted global source of essential and advanced chemicals, empowering scientists and researchers to drive progress in science and industry.

Contact

Address: 3281 E Guasti Rd

Ontario, CA 91761, United States

Phone: (601) 213-4426

Email: info@benchchem.com