

mitigating potential toxicity of UNC2025 in animal models

Author: BenchChem Technical Support Team. **Date:** December 2025

Compound of Interest

Compound Name: UNC2025

Cat. No.: B10799184

[Get Quote](#)

Technical Support Center: UNC2025 in Animal Models

This technical support center provides guidance for researchers, scientists, and drug development professionals on mitigating the potential toxicity of **UNC2025** in animal models. The information is presented in a question-and-answer format to directly address common issues encountered during in vivo experiments.

Frequently Asked Questions (FAQs)

Q1: What is **UNC2025** and what is its primary mechanism of action?

UNC2025 is a potent, orally bioavailable small molecule inhibitor of MER proto-oncogene tyrosine kinase (MERTK) and Fms-like tyrosine kinase 3 (FLT3).^{[1][2][3][4][5]} Its therapeutic potential has been investigated primarily in the context of acute leukemia.^{[1][6][7][8]} **UNC2025** functions as an ATP-competitive inhibitor, blocking the phosphorylation and activation of MERTK and FLT3, thereby inhibiting downstream pro-survival signaling pathways.^{[1][3][9][10]}

Q2: What are the known toxicities of **UNC2025** in animal models?

The primary toxicities observed with **UNC2025** administration in mice are hematological.^{[1][11]} These include:

- Leukopenia: A significant decrease in the total number of white blood cells (WBCs).^[1]

- Anemia: Characterized by a reduction in red blood cell (RBC) count, hemoglobin concentration, and hematocrit.[1]

These side effects are considered manageable and have not been reported as dose-limiting in preclinical leukemia studies.[1][11] The hematological toxicity is likely attributable to the inhibition of FLT3 in the bone marrow.[11]

Q3: At what dose are toxicities typically observed?

In C57Bl/6 mice, daily administration of 75 mg/kg **UNC2025** for 24 days resulted in significant leukopenia and anemia.[1] However, therapeutic effects in leukemia xenograft models have been observed at doses of 50 mg/kg and 75 mg/kg, with these doses being well-tolerated for extended periods (up to 110-150 days).[1][11]

Troubleshooting Guide

Issue 1: Severe weight loss or signs of distress in treated animals.

- Possible Cause: While **UNC2025** is generally well-tolerated, individual animal responses can vary. Severe weight loss may indicate excessive toxicity.
- Troubleshooting Steps:
 - Monitor Animal Health: Implement a rigorous health monitoring schedule, including daily weight checks and clinical observation for signs of distress (e.g., lethargy, ruffled fur, hunched posture).
 - Dose Reduction: Consider a dose de-escalation study to determine the maximum tolerated dose (MTD) in your specific animal model and strain.
 - Combination Therapy: Explore combining a lower dose of **UNC2025** with other therapeutic agents. For instance, **UNC2025** has been shown to work synergistically with methotrexate, which could allow for a reduction in the **UNC2025** dose and its associated toxicities.[1][6][7]

Issue 2: Unexpected mortality in the treatment group.

- Possible Cause: Off-target effects or severe, unmonitored hematological toxicity.

- Troubleshooting Steps:
 - Hematological Monitoring: Conduct complete blood counts (CBCs) at baseline and regular intervals throughout the study to monitor for the development of severe anemia or leukopenia.
 - Necropsy and Histopathology: If unexpected mortality occurs, perform a thorough necropsy and histopathological analysis of major organs to identify any potential off-target toxicities.
 - Review Dosing Regimen: Ensure the dosing formulation and administration are accurate. **UNC2025** has high oral bioavailability and solubility in saline.[1]

Quantitative Data Summary

Table 1: Hematological Effects of **UNC2025** in C57Bl/6 Mice

Parameter	Vehicle Control	75 mg/kg UNC2025 (24 days)	Percentage Change
White Blood Cells (WBCs) (x10 ³ /μL)	5.37	1.46	-72.8%
Red Blood Cells (RBCs)	Not specified	Significant decrease	~61% reduction
Hemoglobin	Not specified	Significant decrease	~61% reduction
Hematocrit	Not specified	Significant decrease	~65% reduction

Data sourced from studies on C57Bl/6 mice treated for 24 days.[1]

Experimental Protocols

Protocol 1: Monitoring Hematological Toxicity

- Baseline Blood Collection: Prior to the first dose of **UNC2025**, collect a baseline blood sample (e.g., via tail vein or retro-orbital sinus) for a complete blood count (CBC).

- Treatment Administration: Administer **UNC2025** orally at the desired dose and schedule. A common vehicle is saline.[1]
- Interim Blood Collection: Collect blood samples at regular intervals (e.g., weekly) throughout the study.
- CBC Analysis: Analyze blood samples for key hematological parameters, including WBC count, RBC count, hemoglobin, and hematocrit.
- Data Analysis: Compare the hematological parameters of the **UNC2025**-treated group to the vehicle-treated control group to assess the degree of toxicity.

Visualizations

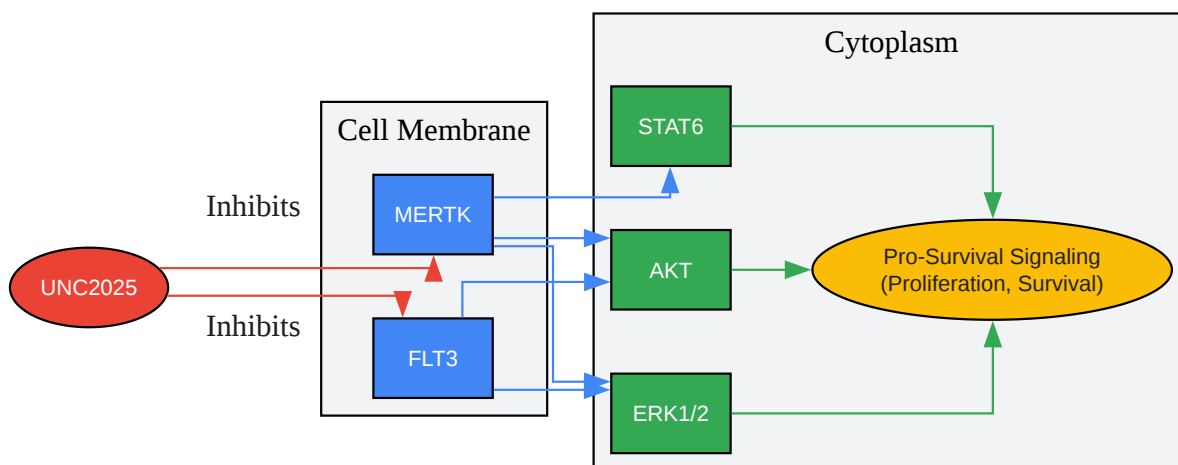

[Click to download full resolution via product page](#)

Caption: **UNC2025** inhibits MERTK and FLT3 signaling pathways.

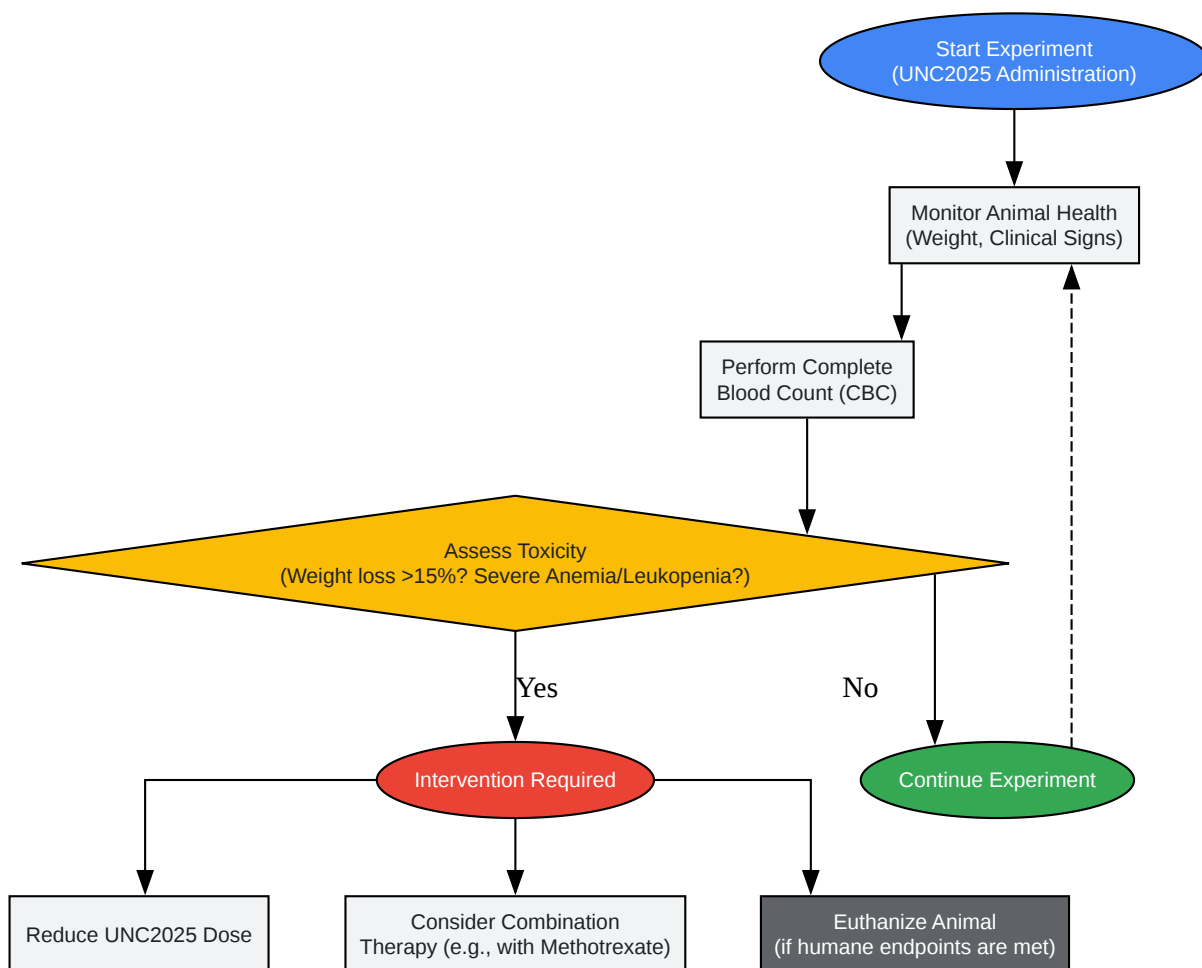

[Click to download full resolution via product page](#)

Need Custom Synthesis?

BenchChem offers custom synthesis for rare earth carbides and specific isotopic labeling.

Email: info@benchchem.com or [Request Quote Online](#).

References

- 1. UNC2025, a MERTK small molecule inhibitor, is therapeutically effective alone and in combination with methotrexate in leukemia models - PMC [pmc.ncbi.nlm.nih.gov]
- 2. researchgate.net [researchgate.net]
- 3. medchemexpress.com [medchemexpress.com]
- 4. selleckchem.com [selleckchem.com]
- 5. selleckchem.com [selleckchem.com]
- 6. ashpublications.org [ashpublications.org]
- 7. Collection - Data from UNC2025, a MERTK Small-Molecule Inhibitor, Is Therapeutically Effective Alone and in Combination with Methotrexate in Leukemia Models - Clinical Cancer Research - Figshare [aacr.figshare.com]
- 8. UNC2025, a MERTK Small-Molecule Inhibitor, Is Therapeutically Effective Alone and in Combination with Methotrexate in Leukemia Models - PubMed [pubmed.ncbi.nlm.nih.gov]
- 9. pubs.acs.org [pubs.acs.org]
- 10. UNC2025, a Potent and Orally Bioavailable MER/FLT3 Dual Inhibitor - PMC [pmc.ncbi.nlm.nih.gov]
- 11. The small molecule MERTK inhibitor UNC2025 decreases platelet activation and prevents thrombosis - PMC [pmc.ncbi.nlm.nih.gov]
- To cite this document: BenchChem. [mitigating potential toxicity of UNC2025 in animal models]. BenchChem, [2025]. [Online PDF]. Available at: [https://www.benchchem.com/product/b10799184#mitigating-potential-toxicity-of-unc2025-in-animal-models]

Disclaimer & Data Validity:

The information provided in this document is for Research Use Only (RUO) and is strictly not intended for diagnostic or therapeutic procedures. While BenchChem strives to provide accurate protocols, we make no warranties, express or implied, regarding the fitness of this product for every specific experimental setup.

Technical Support: The protocols provided are for reference purposes. Unsure if this reagent suits your experiment? [[Contact our Ph.D. Support Team for a compatibility check](#)]

Need Industrial/Bulk Grade? [Request Custom Synthesis Quote](#)

BenchChem

Our mission is to be the trusted global source of essential and advanced chemicals, empowering scientists and researchers to drive progress in science and industry.

Contact

Address: 3281 E Guasti Rd

Ontario, CA 91761, United States

Phone: (601) 213-4426

Email: info@benchchem.com