

interpreting unexpected results in W-54011 experiments

Author: BenchChem Technical Support Team. **Date:** December 2025

Compound of Interest

Compound Name: W-54011

Cat. No.: B15623039

[Get Quote](#)

Technical Support Center: W-54011 Experiments

This technical support center provides troubleshooting guides and frequently asked questions (FAQs) to help researchers interpret unexpected results in experiments involving the hypothetical MEK1/2 inhibitor, **W-54011**.

Frequently Asked Questions (FAQs)

Q1: We observe a decrease in cell viability with **W-54011** in our primary screen, but the effect is weaker than expected. What could be the reason?

A1: A weaker-than-expected effect of **W-54011** on cell viability could be due to several factors:

- **Intrinsic Resistance:** The cell line used may possess intrinsic resistance to MEK inhibitors. This can be caused by pre-existing mutations in genes upstream or downstream of MEK in the MAPK pathway, or activation of compensatory signaling pathways.^{[1][2][3]}
- **Suboptimal Compound Concentration or Treatment Duration:** The concentration of **W-54011** used may be too low, or the treatment duration may be too short to induce a significant biological response. It is crucial to perform a dose-response and time-course experiment to determine the optimal conditions.
- **Cell Culture Conditions:** Factors such as cell density, serum concentration in the media, and passage number can influence the cellular response to drug treatment. Ensure consistency

in these parameters across experiments.

- **Compound Stability:** Ensure that the **W-54011** stock solution is stable and has been stored correctly. Degradation of the compound will lead to reduced activity.

Q2: After an initial strong response to **W-54011**, our cells develop resistance and resume proliferation. What is the likely mechanism?

A2: This phenomenon is known as acquired resistance and is a common observation with targeted therapies like MEK inhibitors. Potential mechanisms include:

- **Reactivation of the MAPK Pathway:** Cells can develop secondary mutations in components of the MAPK pathway, such as MEK1/2 itself or upstream activators like RAS or RAF, that render the inhibitor less effective.^{[2][3]} Amplification of the BRAF gene is another possibility.^[2]
- **Activation of Bypass Pathways:** Cancer cells can adapt by upregulating alternative signaling pathways to maintain proliferation and survival, thereby bypassing the need for MEK signaling. The PI3K/AKT/mTOR pathway is a common bypass route.^{[4][5]}
- **Phenotype Switching:** Tumor cells may undergo processes like the epithelial-mesenchymal transition (EMT), which can confer drug resistance.^[4]

Q3: We are observing paradoxical activation of ERK phosphorylation at certain concentrations of **W-54011**. Is this a known phenomenon?

A3: Yes, paradoxical activation of the MAPK pathway has been reported with some RAF and MEK inhibitors. This can occur in cells with wild-type BRAF and certain RAS mutations. Some MEK1/2 inhibitors can increase the interaction between MEK1/2 and C-Raf, leading to increased MEK phosphorylation and subsequent ERK activation.^[2] This effect is typically observed at low concentrations of the inhibitor.

Q4: Are there any known off-target effects of MEK inhibitors that could explain unexpected phenotypes in our experiments?

A4: While **W-54011** is a hypothetical compound, real-world MEK inhibitors can have off-target effects. For example, some older MEK inhibitors like U0126 and PD98059 have been reported

to affect AMPK activity and mitochondrial respiration.[6] Other off-target effects can include interference with calcium homeostasis.[7][6] It is crucial to use highly selective inhibitors and include appropriate controls to distinguish on-target from off-target effects.

Troubleshooting Guides

Issue 1: High Background Signal in Western Blot for Phospho-ERK

Possible Cause	Troubleshooting Step
Antibody Specificity	Validate the phospho-ERK antibody using positive and negative controls (e.g., cells stimulated with a growth factor vs. serum-starved cells).
Blocking Inefficiency	Increase the blocking time or try a different blocking agent (e.g., 5% BSA in TBST instead of non-fat dry milk).
Antibody Concentration	Titrate the primary and secondary antibody concentrations to find the optimal signal-to-noise ratio.
Washing Steps	Increase the number and duration of washing steps with TBST to remove non-specific antibody binding.

Issue 2: Inconsistent IC50 Values for W-54011 Across Experiments

Possible Cause	Troubleshooting Step
Cell Passage Number	Use cells within a consistent and narrow passage number range for all experiments, as cell characteristics can change over time in culture.
Inconsistent Seeding Density	Ensure precise and consistent cell seeding density for all wells in the assay plate.
Assay Reagent Variability	Prepare fresh assay reagents for each experiment and ensure they are properly stored.
Edge Effects in Assay Plates	Avoid using the outer wells of microplates, which are more prone to evaporation and temperature fluctuations. Fill these wells with sterile PBS.

Data Presentation

Table 1: Dose-Response of W-54011 on Cell Viability in Different Cancer Cell Lines

Cell Line	BRAF Status	KRAS Status	W-54011 IC50 (nM)
HT-29	V600E	WT	15
A549	WT	G12S	250
HCT116	WT	G13D	180
SK-MEL-28	V600E	WT	10

This table presents hypothetical IC50 values for **W-54011** in various cancer cell lines, illustrating the differential sensitivity based on their mutational status.

Table 2: Effect of W-54011 on MAPK Pathway Phosphorylation

Treatment	p-MEK (Ser217/221) (% of Control)	p-ERK1/2 (Thr202/Tyr204) (% of Control)
Vehicle Control	100	100
W-54011 (10 nM)	110	45
W-54011 (100 nM)	125	15
W-54011 (1 μ M)	130	5

This table shows hypothetical data from a Western blot analysis, demonstrating the paradoxical increase in MEK phosphorylation and the expected dose-dependent decrease in ERK phosphorylation upon treatment with **W-54011**.

Experimental Protocols

Protocol 1: Cell Viability Assay (MTS Assay)

- Cell Seeding: Seed cells in a 96-well plate at a density of 5,000 cells/well in 100 μ L of complete growth medium. Incubate for 24 hours at 37°C and 5% CO₂.
- Compound Treatment: Prepare a serial dilution of **W-54011** in complete growth medium. Remove the old medium from the wells and add 100 μ L of the compound dilutions. Include a vehicle control (e.g., 0.1% DMSO).
- Incubation: Incubate the plate for 72 hours at 37°C and 5% CO₂.
- MTS Reagent Addition: Add 20 μ L of MTS reagent to each well.
- Incubation: Incubate the plate for 2-4 hours at 37°C and 5% CO₂, protected from light.
- Absorbance Reading: Measure the absorbance at 490 nm using a microplate reader.
- Data Analysis: Calculate the percentage of cell viability relative to the vehicle control and determine the IC₅₀ value using a non-linear regression curve fit.

Protocol 2: Western Blotting for MAPK Pathway Proteins

- Cell Lysis: Treat cells with **W-54011** at the desired concentrations and time points. Wash the cells with ice-cold PBS and lyse them in RIPA buffer supplemented with protease and phosphatase inhibitors.
- Protein Quantification: Determine the protein concentration of the lysates using a BCA protein assay.
- SDS-PAGE: Denature 20-30 µg of protein from each sample by boiling in Laemmli buffer. Separate the proteins on a 10% SDS-polyacrylamide gel.
- Protein Transfer: Transfer the separated proteins to a PVDF membrane.
- Blocking: Block the membrane with 5% non-fat dry milk or BSA in TBST for 1 hour at room temperature.
- Primary Antibody Incubation: Incubate the membrane with primary antibodies against p-MEK, MEK, p-ERK, ERK, and a loading control (e.g., GAPDH or β-actin) overnight at 4°C.
- Washing: Wash the membrane three times with TBST for 10 minutes each.
- Secondary Antibody Incubation: Incubate the membrane with the appropriate HRP-conjugated secondary antibody for 1 hour at room temperature.
- Washing: Wash the membrane three times with TBST for 10 minutes each.
- Detection: Visualize the protein bands using an enhanced chemiluminescence (ECL) substrate and an imaging system.
- Densitometry Analysis: Quantify the band intensities using image analysis software and normalize to the loading control.

Visualizations

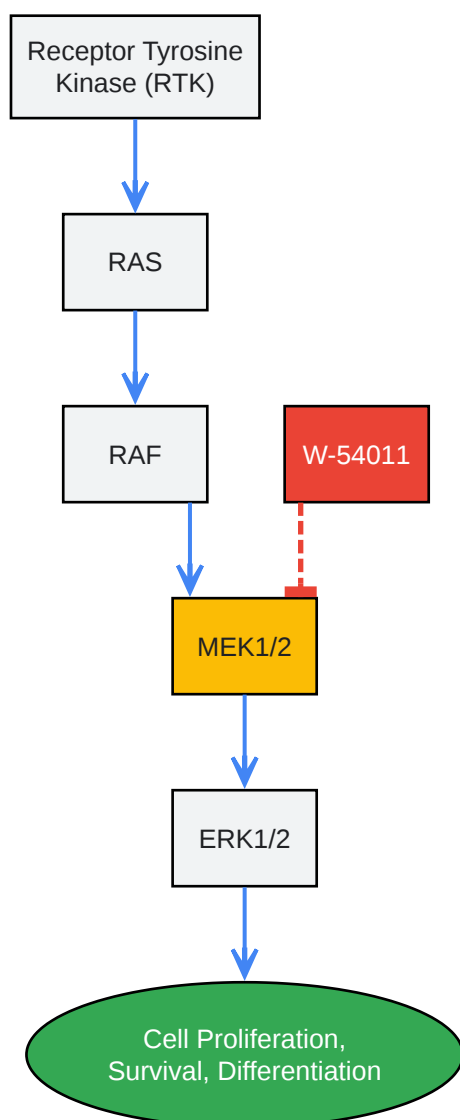

[Click to download full resolution via product page](#)

Caption: The MAPK signaling pathway and the inhibitory action of **W-54011** on MEK1/2.

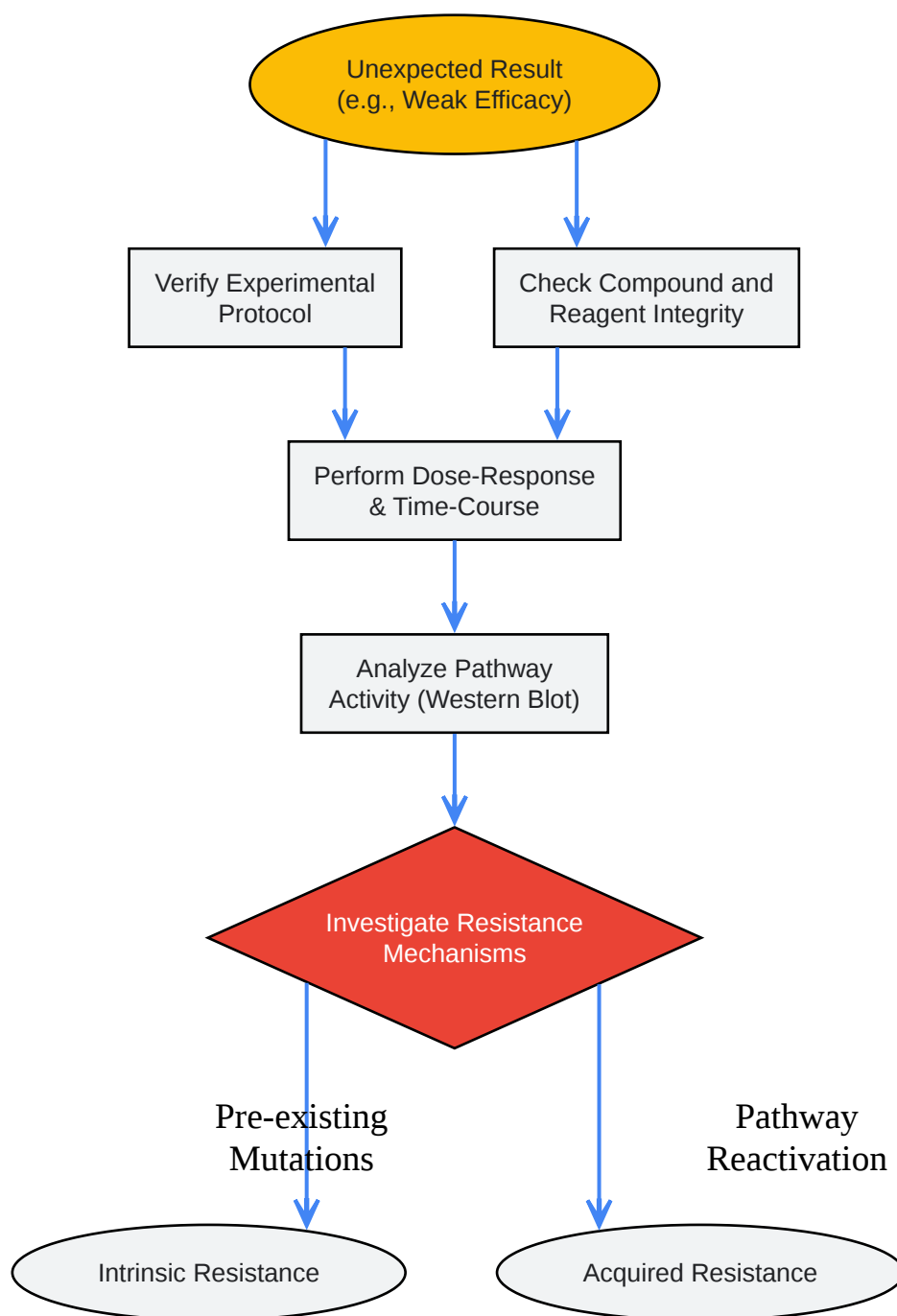

[Click to download full resolution via product page](#)

Need Custom Synthesis?

BenchChem offers custom synthesis for rare earth carbides and specific isotopic labeling.

Email: info@benchchem.com or [Request Quote Online](#).

References

- 1. mdanderson.elsevierpure.com [mdanderson.elsevierpure.com]
- 2. MEK1/2 Inhibitors: Molecular Activity and Resistance Mechanisms - PMC [[pmc.ncbi.nlm.nih.gov](https://pubmed.ncbi.nlm.nih.gov/)]
- 3. mdpi.com [mdpi.com]
- 4. aacrjournals.org [aacrjournals.org]
- 5. Mechanisms of resistance to BRAF and MEK inhibitors and clinical update of US Food and Drug Administration-approved targeted therapy in advanced melanoma - PMC [[pmc.ncbi.nlm.nih.gov](https://pubmed.ncbi.nlm.nih.gov/)]
- 6. Off-target effects of MEK inhibitors - PMC [[pmc.ncbi.nlm.nih.gov](https://pubmed.ncbi.nlm.nih.gov/)]
- 7. pubs.acs.org [pubs.acs.org]
- To cite this document: BenchChem. [interpreting unexpected results in W-54011 experiments]. BenchChem, [2025]. [Online PDF]. Available at: [<https://www.benchchem.com/product/b15623039#interpreting-unexpected-results-in-w-54011-experiments>]

Disclaimer & Data Validity:

The information provided in this document is for Research Use Only (RUO) and is strictly not intended for diagnostic or therapeutic procedures. While BenchChem strives to provide accurate protocols, we make no warranties, express or implied, regarding the fitness of this product for every specific experimental setup.

Technical Support: The protocols provided are for reference purposes. Unsure if this reagent suits your experiment? [[Contact our Ph.D. Support Team for a compatibility check](#)]

Need Industrial/Bulk Grade? [Request Custom Synthesis Quote](#)

BenchChem

Our mission is to be the trusted global source of essential and advanced chemicals, empowering scientists and researchers to drive progress in science and industry.

Contact

Address: 3281 E Guasti Rd

Ontario, CA 91761, United States

Phone: (601) 213-4426

Email: info@benchchem.com