

# interpreting unexpected data from DS28120313 experiments

**Author:** BenchChem Technical Support Team. **Date:** December 2025

## Compound of Interest

Compound Name: DS28120313

Cat. No.: B15610518

[Get Quote](#)

## Technical Support Center: DS28120313 Experiments

This technical support center provides troubleshooting guidance and frequently asked questions (FAQs) for researchers using **DS28120313**, a potent inhibitor of hepcidin production. [1] This guide is intended for researchers, scientists, and drug development professionals to interpret unexpected data and refine their experimental approaches.

### Frequently Asked Questions (FAQs)

Q1: What is the primary mechanism of action for **DS28120313**?

A1: **DS28120313** is an orally active small molecule that inhibits the production of hepcidin. [1] Hepcidin is the central regulatory hormone of systemic iron homeostasis. [2][3][4] By inhibiting hepcidin, **DS28120313** is expected to increase iron availability in the circulation.

Q2: Which signaling pathways are most relevant to the action of **DS28120313**?

A2: The primary signaling pathways regulating hepcidin production, and therefore relevant to the effects of **DS28120313**, are the Bone Morphogenetic Protein (BMP)/SMAD pathway and the Janus Kinase (JAK)/Signal Transducer and Activator of Transcription (STAT) pathway, which is activated by inflammatory cytokines like Interleukin-6 (IL-6). [3][4][5] The BMP-SMAD pathway is considered the core axis of hepcidin control. [6]

Q3: What are the expected downstream effects of **DS28120313** treatment?

A3: By inhibiting hepcidin production, **DS28120313** is expected to lead to an increase in the expression and stability of ferroportin, the only known cellular iron exporter.[3][4] This should result in increased iron export from enterocytes, macrophages, and hepatocytes into the plasma, leading to elevated serum iron levels.

Q4: What are the standard assays to measure the effectiveness of **DS28120313**?

A4: The effectiveness of **DS28120313** can be assessed by measuring:

- Hepcidin levels: Serum or plasma hepcidin can be measured using immunoassays (e.g., ELISA) or mass spectrometry-based methods.[7][8]
- Serum iron parameters: A standard iron panel including serum iron, total iron-binding capacity (TIBC), transferrin saturation, and ferritin should be evaluated.[9]
- Gene expression: Quantitative PCR (qPCR) to measure the mRNA levels of HAMP (the gene encoding hepcidin) in liver tissue or cultured hepatocytes.

## Troubleshooting Unexpected Experimental Results

### Scenario 1: No significant decrease in hepcidin levels after **DS28120313** treatment.

Potential Cause	Troubleshooting Steps
Inadequate Drug Concentration or Bioavailability	Verify the dose and administration route. For in vivo studies, perform pharmacokinetic analysis to confirm drug exposure. For in vitro studies, ensure the correct concentration is used and that the compound is soluble in the culture medium.
High Inflammatory State	If the experimental model involves inflammation (e.g., LPS or IL-6 stimulation), the inflammatory stimulus may be overriding the inhibitory effect of DS28120313. <sup>[3][10]</sup> Consider increasing the dose of DS28120313 or modulating the inflammatory stimulus.
Assay-related Issues	Ensure the hepcidin assay is validated for your sample type (e.g., human, mouse, rat). Different isoforms of hepcidin exist, and assay specificity can vary. <sup>[8]</sup> Consider using a mass spectrometry-based method for higher specificity. <sup>[7]</sup>
Cell Line Unresponsiveness	If using a cell line, confirm that it expresses the necessary components of the hepcidin regulatory pathways (e.g., BMP receptors, SMADs).

## Scenario 2: Unexpected changes in iron parameters despite a decrease in hepcidin.

Potential Cause	Troubleshooting Steps
Delayed or Compensatory Response	The physiological response to decreased hepcidin may be delayed. Consider extending the time course of the experiment to observe changes in serum iron and other parameters.
Underlying Iron Deficiency or Overload	The baseline iron status of the animal model or cell culture conditions can significantly impact the response to hepcidin inhibition. <sup>[11]</sup> Ensure that the baseline iron status is well-characterized and controlled.
Off-Target Effects	While DS28120313 is designed to be a specific hepcidin inhibitor, off-target effects cannot be entirely ruled out and are a common cause of unexpected drug efficacy. <sup>[12]</sup> Consider performing transcriptomic or proteomic analysis to identify potential off-target pathways affected by the compound.

## Scenario 3: High variability in experimental replicates.

Potential Cause	Troubleshooting Steps
Inconsistent Dosing or Sample Collection	Standardize the timing of drug administration and sample collection. Hepcidin levels can exhibit circadian oscillations. <sup>[11]</sup>
Variations in Animal Models	Ensure that the age, sex, and genetic background of the animals are consistent across experimental groups.
Dietary Iron Content	The iron content of the animal chow can influence baseline hepcidin levels and the response to treatment. Use a standardized diet with a known iron concentration.

## Experimental Protocols

## Measurement of Hepcidin mRNA in Liver Tissue by qPCR

- Tissue Homogenization: Homogenize 20-30 mg of liver tissue in a suitable lysis buffer (e.g., TRIzol) using a bead mill or rotor-stator homogenizer.
- RNA Extraction: Extract total RNA using a column-based kit or phenol-chloroform extraction. Assess RNA quality and quantity using a spectrophotometer (e.g., NanoDrop) and agarose gel electrophoresis.
- cDNA Synthesis: Reverse transcribe 1-2  $\mu\text{g}$  of total RNA into cDNA using a high-capacity cDNA reverse transcription kit with random primers.
- qPCR: Perform qPCR using a validated primer set for the HAMP gene and a stable housekeeping gene (e.g., GAPDH, Actb). The reaction mixture should include cDNA template, forward and reverse primers, and a suitable SYBR Green or TaqMan master mix.
- Data Analysis: Calculate the relative expression of HAMP mRNA using the  $\Delta\Delta\text{Ct}$  method, normalizing to the housekeeping gene and comparing treated samples to a vehicle control group.

## Visualizing Key Pathways and Workflows

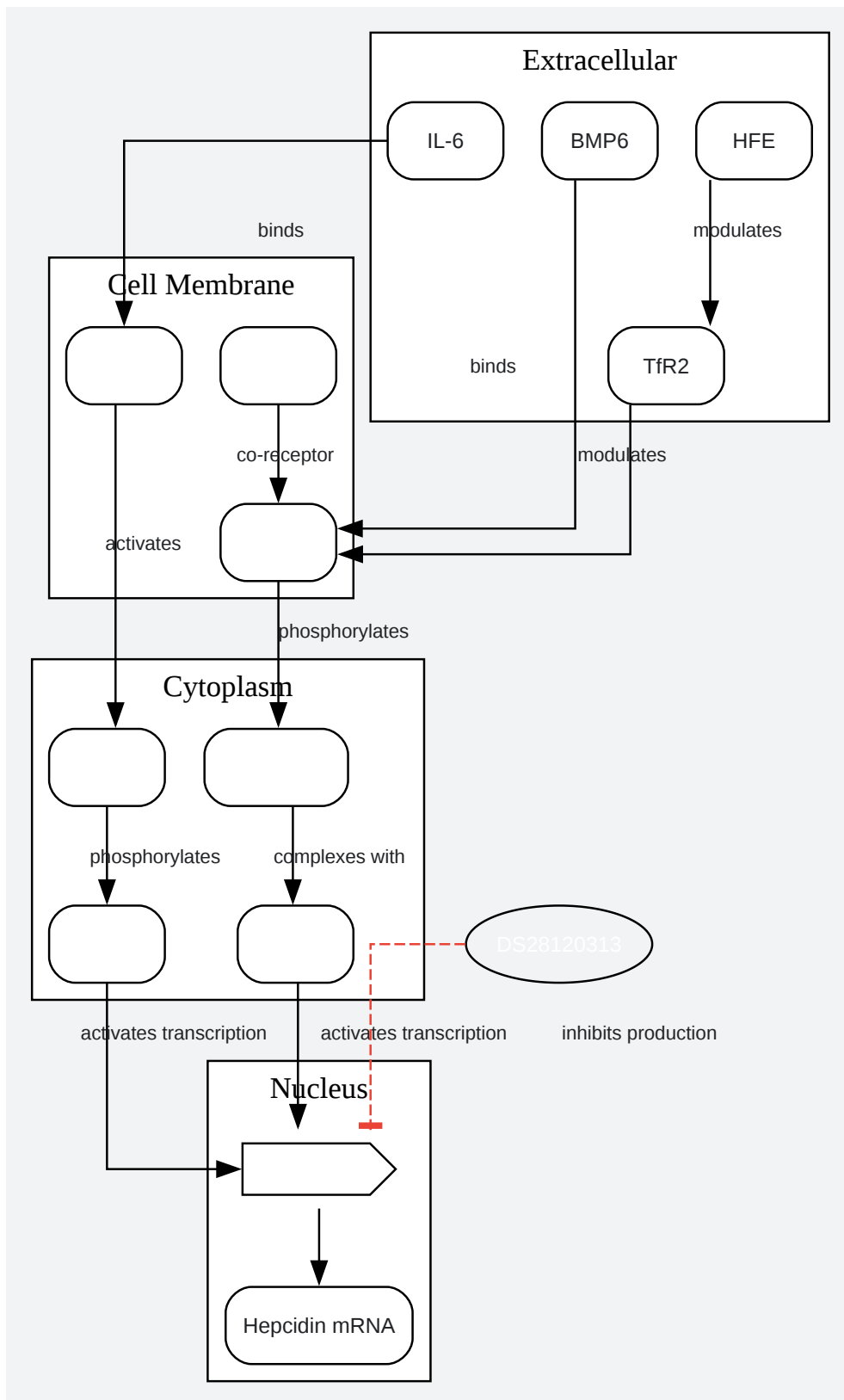

[Click to download full resolution via product page](#)

Caption: Hepcidin Regulation Signaling Pathway.

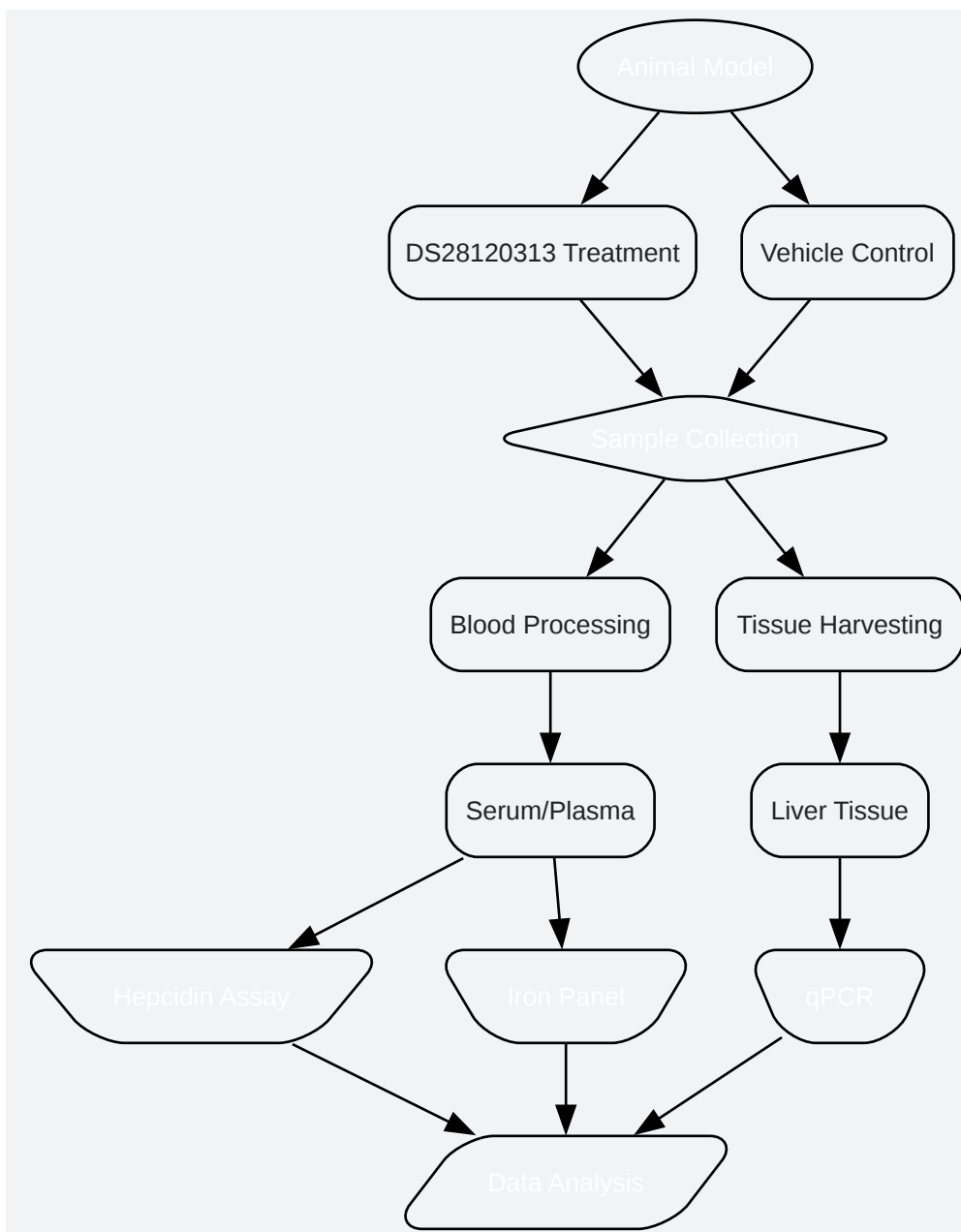

[Click to download full resolution via product page](#)

Caption: In Vivo Experimental Workflow.

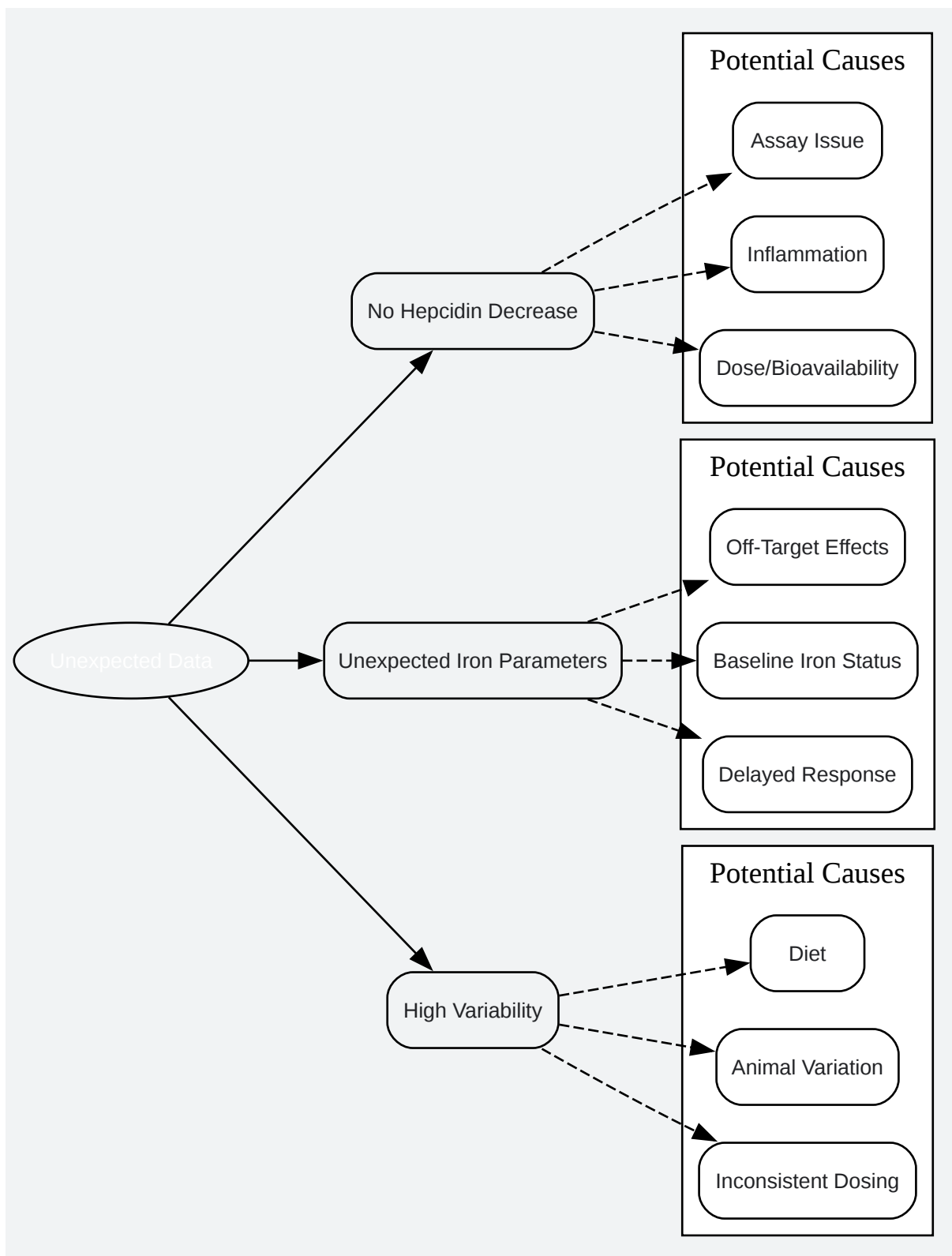

[Click to download full resolution via product page](#)

Caption: Troubleshooting Logic Flow.



### Need Custom Synthesis?

BenchChem offers custom synthesis for rare earth carbides and specific isotopic labeling.

Email: [info@benchchem.com](mailto:info@benchchem.com) or [Request Quote Online](#).

## References

- 1. Discovery of DS28120313 as a potent orally active hepcidin production inhibitor: Design and optimization of novel 4,6-disubstituted indazole derivatives - PubMed [pubmed.ncbi.nlm.nih.gov]
- 2. Signaling pathways regulating hepcidin - PubMed [pubmed.ncbi.nlm.nih.gov]
- 3. Hepcidin: regulation of the master iron regulator - PMC [pmc.ncbi.nlm.nih.gov]
- 4. JCI - Hepcidin regulation: ironing out the details [jci.org]
- 5. Interacting signals in the control of hepcidin expression - PubMed [pubmed.ncbi.nlm.nih.gov]
- 6. ashpublications.org [ashpublications.org]
- 7. scispace.com [scispace.com]
- 8. Hepcidin in the diagnosis of iron disorders - PMC [pmc.ncbi.nlm.nih.gov]
- 9. Physiology, Hepcidin - StatPearls - NCBI Bookshelf [ncbi.nlm.nih.gov]
- 10. To induce or not to induce: the fight over hepcidin regulation - PMC [pmc.ncbi.nlm.nih.gov]
- 11. Iron metabolism and iron disorders revisited in the hepcidin era | Haematologica [haematologica.org]
- 12. Off-target toxicity is a common mechanism of action of cancer drugs undergoing clinical trials - PMC [pmc.ncbi.nlm.nih.gov]
- To cite this document: BenchChem. [interpreting unexpected data from DS28120313 experiments]. BenchChem, [2025]. [Online PDF]. Available at: [https://www.benchchem.com/product/b15610518#interpreting-unexpected-data-from-ds28120313-experiments]

---

### Disclaimer & Data Validity:

The information provided in this document is for Research Use Only (RUO) and is strictly not intended for diagnostic or therapeutic procedures. While BenchChem strives to provide accurate protocols, we make no warranties, express or implied, regarding the fitness of this product for every specific experimental setup.

**Technical Support:** The protocols provided are for reference purposes. Unsure if this reagent suits your experiment? [[Contact our Ph.D. Support Team for a compatibility check](#)]

**Need Industrial/Bulk Grade?** [Request Custom Synthesis Quote](#)

## BenchChem

Our mission is to be the trusted global source of essential and advanced chemicals, empowering scientists and researchers to drive progress in science and industry.

### Contact

Address: 3281 E Guasti Rd  
Ontario, CA 91761, United States  
Phone: (601) 213-4426  
Email: [info@benchchem.com](mailto:info@benchchem.com)