

# improving HPLC method sensitivity for low-level atrazine detection

**Author:** BenchChem Technical Support Team. **Date:** December 2025

## Compound of Interest

Compound Name: Atrazine

Cat. No.: B1667683

[Get Quote](#)

## Technical Support Center: Enhancing Atrazine Detection with HPLC

This technical support center provides troubleshooting guidance and frequently asked questions to assist researchers, scientists, and drug development professionals in improving the sensitivity of High-Performance Liquid Chromatography (HPLC) methods for the detection of low-level **atrazine**.

### Frequently Asked Questions (FAQs)

Q1: What is the most critical first step to improve the sensitivity of my HPLC method for **atrazine**?

A1: The most critical first step is often sample preparation. Techniques like Solid-Phase Extraction (SPE) or liquid-liquid extraction can concentrate the **atrazine** in your sample before it is injected into the HPLC system.<sup>[1][2]</sup> Using an SPE cartridge, such as a C18 cartridge, allows for the enrichment of **atrazine** from a large volume of a dilute sample, which significantly improves detection limits.<sup>[1]</sup>

Q2: Which HPLC column is best suited for low-level **atrazine** analysis?

A2: Reversed-phase columns such as C18, C8, or octadecylsilane (ODS) are commonly used for **atrazine** analysis.<sup>[3]</sup> For enhanced sensitivity and peak shape, columns packed with

superficially porous particles (SPP) or core-shell particles, like Ascentis® Express C18, are an excellent choice.[4][5] These columns provide higher efficiency, leading to narrower and taller peaks, which improves the signal-to-noise ratio without a significant increase in backpressure. [4] Decreasing the column's internal diameter (ID) can also increase sensitivity by reducing sample dilution on the column.[4]

Q3: What mobile phase composition is recommended for sensitive **atrazine** detection?

A3: A common mobile phase for **atrazine** analysis is a mixture of methanol and water or acetonitrile and water.[3][6] For example, a methanol-water ratio of 60:40 (v/v) has been used effectively.[6][7] Using high-purity, HPLC or LC-MS grade solvents is crucial to minimize baseline noise, especially when detecting at low UV wavelengths (e.g., below 220 nm).[4][8] Acetonitrile is often preferred over methanol for detection at low wavelengths due to its lower UV cutoff.[8]

Q4: Which detector offers the best sensitivity for **atrazine**?

A4: While a UV detector set at around 220-230 nm is commonly used, coupling the HPLC system with a Mass Spectrometer (MS) provides significantly higher sensitivity and selectivity. [2][3][6] Other sensitive detectors include fluorescence and electrochemical detectors.[2] For UV detection, a diode array detector (DAD) can also be beneficial.[3]

Q5: How can I reduce baseline noise to improve my limit of detection (LOD)?

A5: Reducing baseline noise is key to improving sensitivity.[9] This can be achieved by:

- Using high-purity solvents and additives (HPLC or MS grade).[8]
- Ensuring proper degassing of the mobile phase to remove dissolved gases.[10][11]
- Regularly cleaning the detector flow cell.[11][12]
- Maintaining a stable column temperature using a column oven.[11]
- Using mobile phase buffers that have low UV absorbance at your detection wavelength, such as phosphate buffers over acetate buffers for low UV detection.[9]

## Troubleshooting Guide

Q1: My chromatogram shows a noisy baseline. What are the likely causes and how can I fix it?

A1: A noisy baseline can stem from several sources. Start by systematically checking the mobile phase for freshness and proper degassing.<sup>[12][13]</sup> Contaminated or old solvents can introduce noise.<sup>[12]</sup> Inspect the detector and flow cell; a dirty flow cell or a failing lamp can be a major contributor.<sup>[11][12]</sup> Also, ensure there are no leaks in the system, particularly between the column and the detector, and that the pump is functioning correctly without introducing pressure fluctuations.<sup>[10][11]</sup>

Q2: I am observing peak tailing for my **atrazine** standard. What should I do?

A2: Peak tailing can be caused by interactions between the analyte and active sites on the stationary phase or by issues with the sample solvent. Ensure your sample is dissolved in a solvent compatible with the mobile phase. Consider adjusting the mobile phase pH. For basic compounds like **atrazine**, a slightly acidic mobile phase can improve peak shape. Also, check if the column is contaminated or degraded; flushing with a strong solvent or replacing the column might be necessary.

Q3: My retention times are shifting from one injection to the next. How can I stabilize them?

A3: Retention time drift is often related to the mobile phase, column, or pump.<sup>[11][14]</sup>

- Mobile Phase: Ensure the mobile phase composition is consistent and freshly prepared. For gradient methods, check that the mixer is working correctly.<sup>[11]</sup>
- Column: The column must be properly equilibrated before analysis. Insufficient equilibration time can lead to shifting retention times.<sup>[11]</sup> Also, ensure the column temperature is stable by using a column oven.<sup>[11]</sup>
- Pump: Check the HPLC pump for consistent flow rates and look for any leaks in the system.<sup>[14]</sup>

Q4: I am not achieving the required low limit of detection (LOD). What parameters can I adjust?

A4: To lower your LOD, you can either increase the signal intensity or decrease the baseline noise.[4]

- Increase Signal:
  - Increase the injection volume, but be mindful of potential peak shape distortion.[9]
  - Use a column with a smaller internal diameter (ID) to reduce on-column dilution.[4]
  - Employ a column with smaller particles or core-shell technology to increase efficiency and peak height.[4]
  - Optimize the mobile phase to ensure sharp, symmetrical peaks.
- Decrease Noise:
  - Use high-purity solvents and additives.[8]
  - Ensure the mobile phase is thoroughly degassed.[10]
  - Clean and maintain the detector regularly.[10]

Q5: My system pressure is fluctuating. What is the cause and how can I resolve it?

A5: Pressure fluctuations are commonly caused by air bubbles in the pump or leaks in the system.[10][12] Start by purging the pump to remove any trapped air.[13] Check all fittings for leaks. Other causes can include faulty check valves in the pump or clogged filters/frits, which may need cleaning or replacement.[12][13]

## Data Summary Tables

Table 1: Comparison of HPLC Columns for **Atrazine** Analysis

Column Type	Particle Type	Dimensions (L x ID, Particle Size)	Advantages	Reference
Agilent TC-C18(2)	Fully Porous Silica	150 mm x 4.6 mm, 5 µm	Good peak symmetry and reproducibility.	[1]
Ascentis® Express C18	Superficially Porous	10 cm x 3.0 mm, 2.7 µm	High efficiency, narrower peaks, increased sensitivity.	[4]
Standard C18	Fully Porous Silica	N/A	Widely available and commonly used.	[6][7]

Table 2: HPLC Method Parameters for **Atrazine** Detection

Parameter	Method 1	Method 2	Method 3
Column	C18	Agilent TC-C18(2)	Ascentis® Express C18
Mobile Phase	Methanol:Water (60:40, v/v)	Methanol:Water (55:45, v/v)	A: 20 mM ammonium acetate; B: Acetonitrile (Gradient)
Flow Rate	1.0 mL/min	N/A	0.6 mL/min
Detector	UV @ 230 nm	UV	UV @ 240 nm
Injection Volume	20 µL	N/A	5 µL
Column Temp.	N/A	N/A	46 °C
Reference	[6]	[1]	[5]

## Detailed Experimental Protocols

## Protocol 1: Sample Preparation using Solid-Phase Extraction (SPE)

This protocol is adapted for concentrating **atrazine** from water samples.<sup>[1]</sup>

- **Cartridge Conditioning:** Condition an AccuBond C18 SPE cartridge by washing it with 5 mL of methanol followed by 5 mL of reagent water. Ensure the cartridge does not go dry after the water wash.
- **Sample Loading:** Pass a known volume of the water sample (e.g., 500 mL) through the conditioned SPE cartridge at a flow rate of approximately 10 mL/min.
- **Cartridge Washing:** Wash the cartridge with 5 mL of reagent water to remove any interfering polar compounds.
- **Analyte Elution:** Elute the retained **atrazine** from the cartridge with a small volume of methanol (e.g., 2 x 1 mL).
- **Concentration:** Evaporate the methanol eluate to dryness under a gentle stream of nitrogen.
- **Reconstitution:** Reconstitute the residue in a small, precise volume (e.g., 200 µL) of the HPLC mobile phase. The sample is now ready for injection.

## Protocol 2: HPLC Analysis of Atrazine

This protocol provides a general methodology for the analysis of **atrazine** using a C18 column.

<sup>[6]</sup>

- **System Preparation:**
  - Prepare the mobile phase: Methanol:Water (60:40, v/v). Filter and degas the mobile phase before use.
  - Install a C18 analytical column.
  - Equilibrate the system by pumping the mobile phase at a flow rate of 1.0 mL/min until a stable baseline is achieved.

- Standard Preparation:
  - Prepare a stock solution of **atrazine** in methanol (e.g., 100 µg/mL).
  - Create a series of calibration standards by diluting the stock solution with the mobile phase to achieve concentrations in the desired range (e.g., 0.1 to 2.0 µg/mL).
- Chromatographic Analysis:
  - Set the UV detector to a wavelength of 230 nm.
  - Inject 20 µL of each standard and sample solution.
  - Record the chromatograms and integrate the peak area for **atrazine**.
- Quantification:
  - Construct a calibration curve by plotting the peak area versus the concentration of the **atrazine** standards.
  - Determine the concentration of **atrazine** in the samples by interpolating their peak areas from the calibration curve.

## Mandatory Visualizations

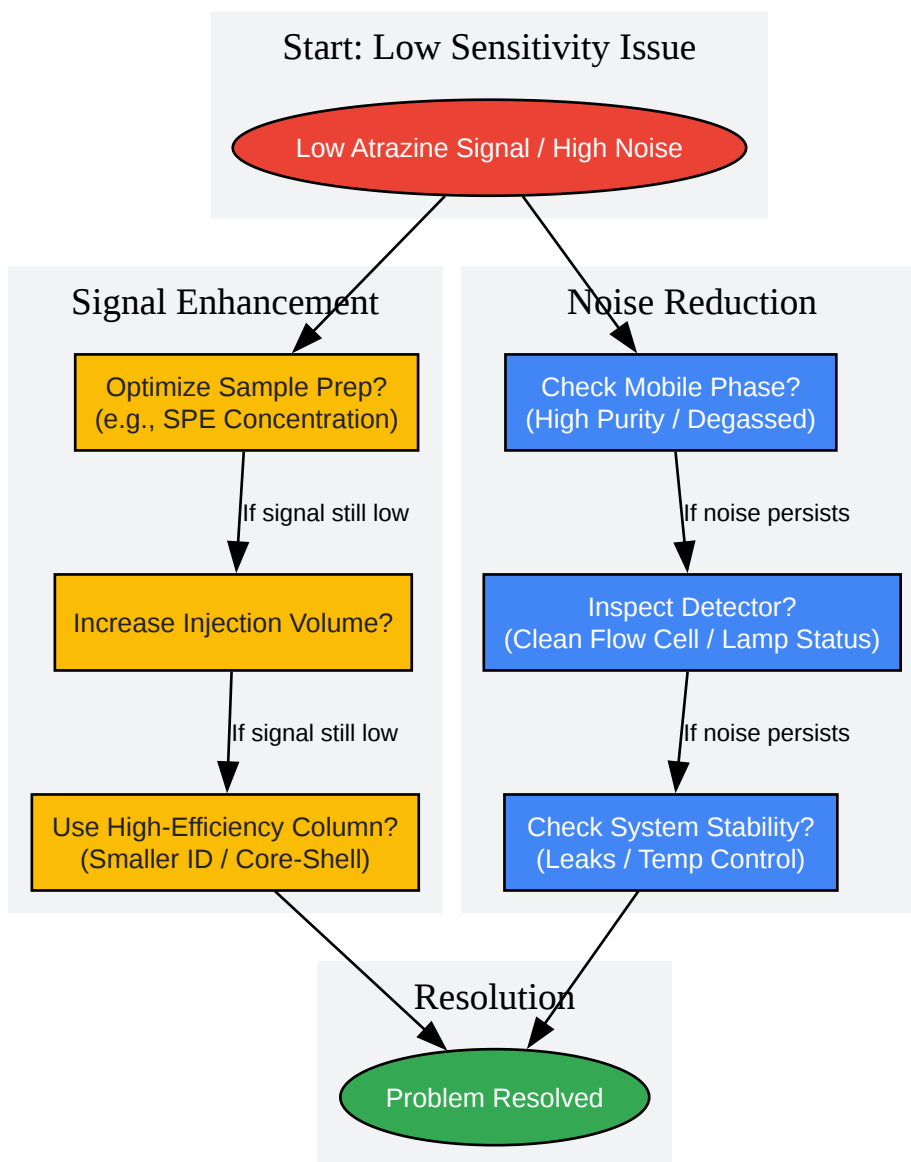

[Click to download full resolution via product page](#)

Caption: Troubleshooting workflow for low HPLC sensitivity.



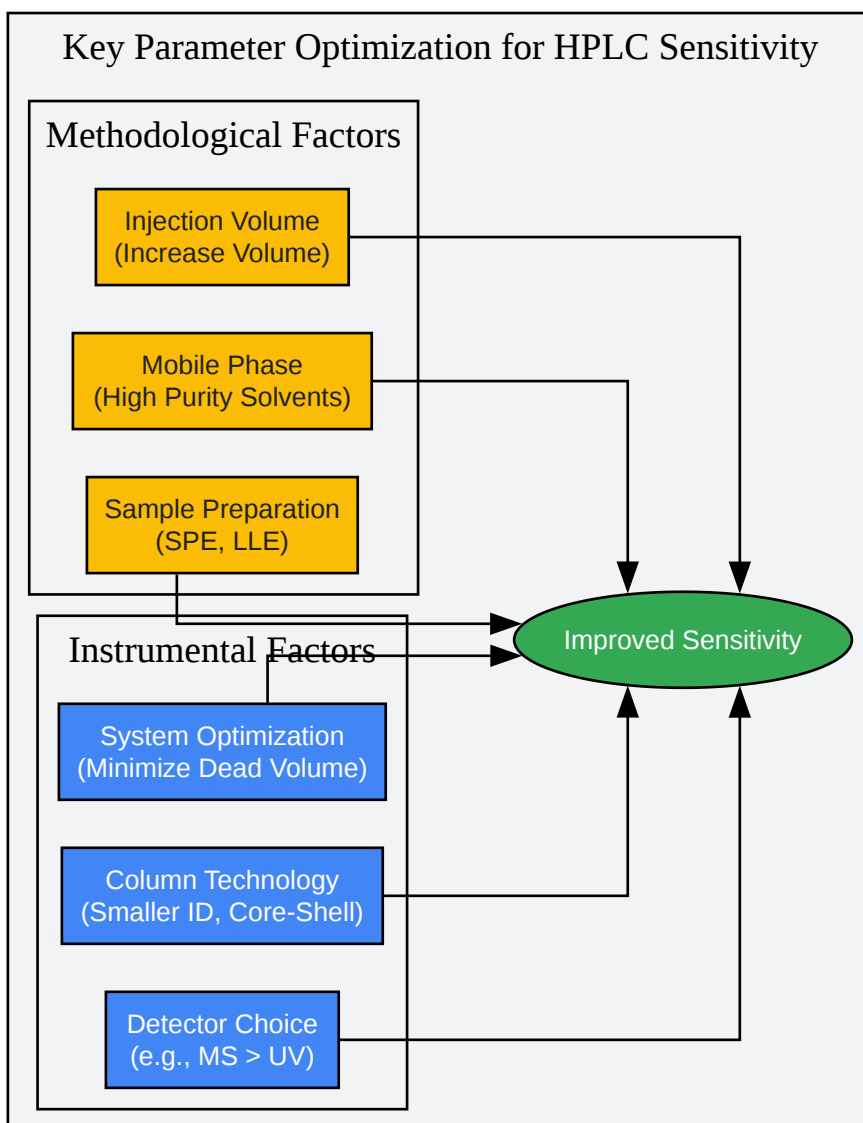

[Click to download full resolution via product page](#)

Caption: Key parameters for HPLC sensitivity optimization.

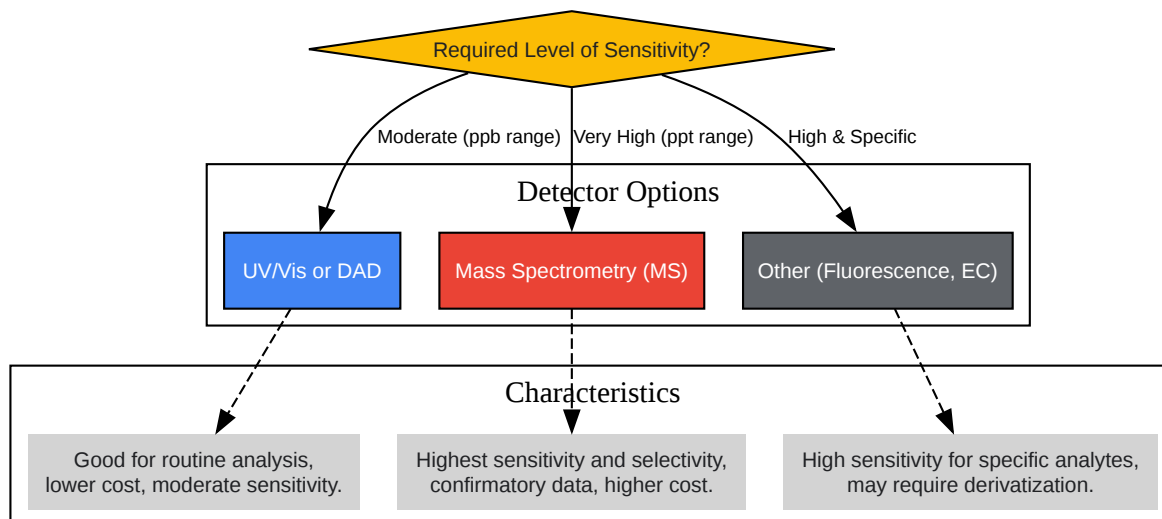

[Click to download full resolution via product page](#)

Caption: Decision tree for selecting an HPLC detector.

### *Need Custom Synthesis?*

*BenchChem offers custom synthesis for rare earth carbides and specific isotopic labeling.*

*Email: [info@benchchem.com](mailto:info@benchchem.com) or [Request Quote Online](#).*

## References

- 1. [agilent.com](http://agilent.com) [[agilent.com](http://agilent.com)]
- 2. How to Achieve Low LOD in HPLC—Key Methods [[eureka.patnap.com](http://eureka.patnap.com)]
- 3. [atsdr.cdc.gov](http://atsdr.cdc.gov) [[atsdr.cdc.gov](http://atsdr.cdc.gov)]
- 4. HPLC Tips & Tricks: Increase Your HPLC/UHPLC Method Sensitivity [[sigmaaldrich.com](http://sigmaaldrich.com)]
- 5. Sigma-Aldrich [[sigmaaldrich.com](http://sigmaaldrich.com)]
- 6. [tandfonline.com](http://tandfonline.com) [[tandfonline.com](http://tandfonline.com)]
- 7. [researchgate.net](http://researchgate.net) [[researchgate.net](http://researchgate.net)]
- 8. [chromatographyonline.com](http://chromatographyonline.com) [[chromatographyonline.com](http://chromatographyonline.com)]

- 9. How to use analytical columns | Technical Information | GL Sciences [glsciences.com]
- 10. Advanced Guide to HPLC Troubleshooting: solve 7 common issues like a pro! [pharmacores.com]
- 11. HPLC Troubleshooting Guide [scioninstruments.com]
- 12. mastelf.com [mastelf.com]
- 13. ijprajournal.com [ijprajournal.com]
- 14. Troubleshooting Common HPLC Issues | Labcompare.com [labcompare.com]
- To cite this document: BenchChem. [improving HPLC method sensitivity for low-level atrazine detection]. BenchChem, [2025]. [Online PDF]. Available at: [https://www.benchchem.com/product/b1667683#improving-hplc-method-sensitivity-for-low-level-atrazine-detection]

---

#### Disclaimer & Data Validity:

The information provided in this document is for Research Use Only (RUO) and is strictly not intended for diagnostic or therapeutic procedures. While BenchChem strives to provide accurate protocols, we make no warranties, express or implied, regarding the fitness of this product for every specific experimental setup.

**Technical Support:** The protocols provided are for reference purposes. Unsure if this reagent suits your experiment? [[Contact our Ph.D. Support Team for a compatibility check](#)]

**Need Industrial/Bulk Grade?** [Request Custom Synthesis Quote](#)

## BenchChem

Our mission is to be the trusted global source of essential and advanced chemicals, empowering scientists and researchers to drive progress in science and industry.

#### Contact

Address: 3281 E Guasti Rd

Ontario, CA 91761, United States

Phone: (601) 213-4426

Email: [info@benchchem.com](mailto:info@benchchem.com)