

# how to improve the efficiency of in-gel digestion for mass spectrometry

**Author:** BenchChem Technical Support Team. **Date:** December 2025

## Compound of Interest

Compound Name: Protein Kinase C Substrate

Cat. No.: B12398245

[Get Quote](#)

## Technical Support Center: In-Gel Digestion for Mass Spectrometry

Welcome to the Technical Support Center for in-gel digestion workflows for mass spectrometry analysis. This guide is designed for researchers, scientists, and drug development professionals to provide troubleshooting assistance and answers to frequently asked questions, ensuring more efficient and reliable experimental outcomes.

### Troubleshooting Guide

This section addresses specific issues that may arise during the in-gel digestion process, offering potential causes and solutions in a question-and-answer format.

Question: Why is my protein digestion incomplete, resulting in low peptide recovery?

Answer: Incomplete digestion is a common issue that can be attributed to several factors:

- **Insufficient Enzyme Activity:** Ensure the trypsin or other protease is fresh and has been stored correctly. Prepare the enzyme solution just before use. Consider increasing the incubation time or the enzyme-to-substrate ratio.<sup>[1][2]</sup> For particularly resistant proteins, a two-step digestion using Lys-C followed by trypsin can be effective, as Lys-C remains active in denaturing conditions.<sup>[1]</sup>

- **Poor Enzyme Penetration:** The enzyme's access to the protein within the gel matrix is crucial. Cut the gel pieces as small as possible (e.g., 1 mm cubes) to increase the surface area for diffusion.[3][4] Dehydration of the gel pieces with acetonitrile followed by rehydration with the enzyme solution can facilitate enzyme uptake.[3]
- **Suboptimal Digestion Conditions:** Maintain the optimal pH for your enzyme (around pH 8 for trypsin) using a suitable buffer like ammonium bicarbonate.[5] The recommended incubation temperature for trypsin is 37°C.[6][7]

Question: I am observing a high number of missed cleavages in my mass spectrometry data. What could be the cause?

Answer: A high number of missed cleavages indicates that the protease is not efficiently cutting at all potential cleavage sites. This can be due to:

- **Insufficient Digestion Time:** Overnight incubation (12-16 hours) is standard for trypsin digestion.[7] For complex samples or highly stable proteins, extending the digestion time may be necessary.
- **Protein Folding:** Inadequate reduction and alkylation can leave disulfide bonds intact, preventing the protein from fully unfolding and restricting enzyme access to cleavage sites. [8][9] Ensure that the reduction and alkylation steps are performed thoroughly.
- **Enzyme Quality:** Use a high-quality, mass spectrometry-grade trypsin to ensure high specific activity. A combination of Trypsin and Lys-C can also help to reduce missed cleavages.[1]

Question: My peptide extraction seems inefficient, leading to low signal intensity in the mass spectrometer. How can I improve it?

Answer: Efficiently extracting the digested peptides from the gel matrix is critical for good mass spectrometry results. To improve peptide extraction:

- **Use an Effective Extraction Solution:** A common and effective extraction solution is a mixture of acetonitrile (ACN) and an acid, such as formic acid (FA) or trifluoroacetic acid (TFA).[3] A typical solution is 50-60% ACN with 1-5% FA or TFA.[3]

- **Perform Multiple Extractions:** A single extraction is often insufficient. Perform at least two to three rounds of extraction to maximize peptide recovery.[10] Pool the supernatants from each extraction step.[11]
- **Agitate the Gel Pieces:** During extraction, agitate the gel pieces to facilitate the diffusion of peptides out of the gel. This can be done by vortexing or sonicating in a water bath.[12]
- **Consider Peptide Properties:** The physicochemical properties of the peptides, such as size and hydrophobicity, can affect extraction efficiency. Adjusting the composition and pH of the extraction solvent can improve the solubility of specific peptides.[10] For larger peptides, freezing the gel pieces in deionized water before extraction can help to disrupt the gel matrix. [10]

Question: I am seeing significant keratin contamination in my samples. How can I minimize this?

Answer: Keratin is a common contaminant originating from skin, hair, and dust. To minimize keratin contamination:

- **Maintain a Clean Workspace:** Work in a clean environment, such as a laminar flow hood.[13]
- **Use Clean Labware:** Use clean, dedicated containers and tools for gel handling and staining. [14] Wear gloves at all times.[13][15]
- **Handle Gels Carefully:** Avoid touching the gel with bare hands. Keep the gel covered during staining and destaining.[14]
- **Use High-Purity Reagents:** Use fresh, high-purity reagents and solvents to avoid introducing contaminants.[14]

## Frequently Asked Questions (FAQs)

This section provides answers to common questions about the in-gel digestion protocol.

What is the purpose of the destaining step? The destaining step is essential to remove the protein stain (e.g., Coomassie Brilliant Blue or silver stain) from the gel. These stains can

interfere with mass spectrometry analysis.[8] A common destaining solution is a mixture of ammonium bicarbonate and acetonitrile.[8]

Why are reduction and alkylation necessary? Reduction and alkylation are performed to break the disulfide bonds within the protein and then permanently modify the resulting free cysteine residues. This process unfolds the protein, making it more accessible to the digestive enzyme and improving the efficiency of digestion.[8][9]

What are the most common enzymes used for in-gel digestion? Trypsin is the most widely used protease for in-gel digestion because it is highly specific, cleaving at the C-terminal side of lysine and arginine residues, which generates peptides of an ideal size for mass spectrometry analysis.[1][3]

Can I use surfactants to improve digestion? Yes, mass spectrometry-compatible surfactants can aid in protein solubilization and denaturation, which can shorten digestion times and increase peptide recovery, especially for hydrophobic proteins.[3][11] It is crucial to use surfactants that do not interfere with downstream mass spectrometry analysis.[11]

How should I store my digested peptide samples? After extraction and drying, the peptide samples should be reconstituted in a solution suitable for mass spectrometry, such as 0.1% TFA in water.[7] For short-term storage, keep the samples at -20°C. For long-term storage, -80°C is recommended.

## Experimental Workflow

The following diagram illustrates the key steps in a typical in-gel digestion workflow.

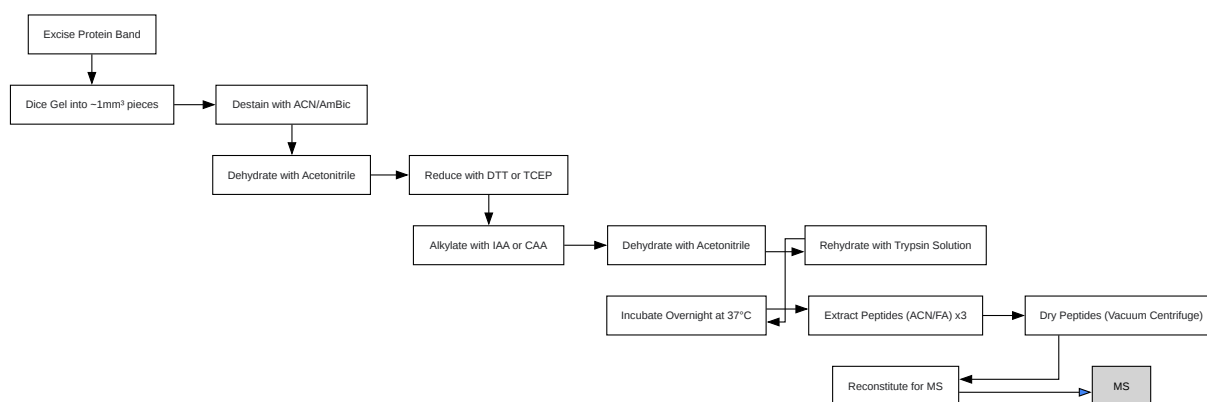

[Click to download full resolution via product page](#)

Caption: In-gel digestion workflow for mass spectrometry.

## Quantitative Data Summary

Recent studies have shown that optimizing the in-gel digestion protocol can significantly improve protein and peptide identification. The following table summarizes a comparison of different methods.

Method	Key Optimization	Improvement in Peptide Identification	Improvement in Protein Identification
Updated Protocol	Simultaneous reduction and alkylation at a higher temperature with Tris(2-carboxyethyl)phosphine (TCEP) and chloroacetamide (CAA), followed by digestion in a HEPES buffer.[6]	Significant Increase	Significant Increase
Surfactant-Assisted Digestion	Addition of a mass spectrometry-compatible surfactant (e.g., ProteaseMAX™) during digestion.[11]	1.5-2 fold increase in recovery	20-30% increase in sequence coverage
In-situ Alkylation	Alkylation of proteins with acrylamide during SDS-PAGE, eliminating the need for separate reduction and alkylation steps post-electrophoresis. [16]	Increased sequence coverage	Not specified

## Detailed Experimental Protocols

### Standard In-Gel Digestion Protocol

This protocol is a widely used method for the in-gel digestion of proteins.

- **Excise and Dice:** Using a clean scalpel, excise the protein band of interest from the gel. Dice the gel band into small pieces (approximately 1 mm<sup>3</sup>).[\[4\]](#)
- **Destain:** Transfer the gel pieces to a microcentrifuge tube. Add enough destaining solution (e.g., 50% acetonitrile in 50 mM ammonium bicarbonate) to cover the gel pieces.[\[6\]](#) Vortex and incubate at room temperature for 15-30 minutes.[\[6\]](#) Repeat until the gel pieces are colorless.[\[15\]](#)
- **Dehydrate:** Remove the destaining solution and add 100% acetonitrile to shrink the gel pieces. Incubate for 5-10 minutes, then remove the acetonitrile and dry the gel pieces in a vacuum centrifuge.[\[15\]](#)
- **Reduction:** Rehydrate the gel pieces in a reduction buffer (e.g., 10 mM DTT in 100 mM ammonium bicarbonate) and incubate at 56°C for 30-60 minutes.[\[6\]](#)[\[17\]](#)
- **Alkylation:** Cool the tube to room temperature and remove the DTT solution. Add an alkylation buffer (e.g., 55 mM iodoacetamide in 100 mM ammonium bicarbonate) and incubate in the dark at room temperature for 20-45 minutes.[\[6\]](#)[\[17\]](#)
- **Wash and Dehydrate:** Remove the alkylation solution and wash the gel pieces with 50 mM ammonium bicarbonate, followed by dehydration with 100% acetonitrile. Dry the gel pieces completely in a vacuum centrifuge.[\[15\]](#)
- **Digestion:** Rehydrate the gel pieces on ice with a minimal volume of trypsin solution (e.g., 10-20 ng/μL in 50 mM ammonium bicarbonate).[\[6\]](#)[\[18\]](#) Once the solution is absorbed, add enough 50 mM ammonium bicarbonate to cover the gel pieces and incubate overnight at 37°C.[\[6\]](#)[\[18\]](#)
- **Peptide Extraction:** Add a small volume of 1% TFA or 5% formic acid to stop the digestion. Transfer the supernatant to a new tube. Add an extraction buffer (e.g., 60% acetonitrile, 1% TFA) to the gel pieces and sonicate or vortex for 10-30 minutes.[\[12\]](#) Collect the supernatant and repeat the extraction at least once more. Pool all supernatants.
- **Drying and Reconstitution:** Dry the pooled extracts in a vacuum centrifuge.[\[11\]](#)[\[15\]](#) Reconstitute the dried peptides in a small volume of 0.1% TFA for mass spectrometry analysis.

## Surfactant-Assisted In-Gel Digestion Protocol

This protocol incorporates a mass spectrometry-compatible surfactant to enhance digestion efficiency.

- Excise, Dice, Destain, Dehydrate, Reduce, and Alkylate: Follow steps 1-6 of the Standard In-Gel Digestion Protocol.
- Digestion with Surfactant: Rehydrate the dried gel pieces in a solution containing trypsin and a mass spectrometry-compatible surfactant (e.g., 0.01% ProteaseMAX™ in 50 mM ammonium bicarbonate).[11] Incubate at 50°C for 1 hour.[11]
- Peptide Extraction: After digestion, add 2.5% TFA and mix vigorously for 15 minutes.[11] Transfer the supernatant to a new tube. Perform a second extraction with 70% ACN/5% TFA. [11] Pool the extracts.
- Drying and Reconstitution: Dry the pooled extracts and reconstitute as described in the standard protocol.

### *Need Custom Synthesis?*

*BenchChem offers custom synthesis for rare earth carbides and specific isotopic labeling.*

*Email: [info@benchchem.com](mailto:info@benchchem.com) or [Request Quote Online](#).*

## References

- 1. Protease Digestion for Mass Spectrometry | Protein Digest Protocols [promega.jp]
- 2. agilent.com [agilent.com]
- 3. Introduce to Protein Digestion—In-Gel or In-Solution - Creative Proteomics [creative-proteomics.com]
- 4. Tutorial: In-gel digestion | Proteomics and Mass Spectrometry Core Facility [sites.psu.edu]
- 5. In-gel digestion | Proteomics and Mass Spectrometry Core Facility [sites.psu.edu]
- 6. Updates of the In-Gel Digestion Method for Protein Analysis by Mass Spectrometry - PMC [pmc.ncbi.nlm.nih.gov]
- 7. nccs.res.in [nccs.res.in]



- 8. In-gel digestion - Wikipedia [en.wikipedia.org]
- 9. researchgate.net [researchgate.net]
- 10. Extracting large peptides from gel after digestion | Proteomics and Mass Spectrometry Core Facility [sites.psu.edu]
- 11. mass-spec.stanford.edu [mass-spec.stanford.edu]
- 12. Protocols: In-Gel Digestion & Mass Spectrometry for ID - Creative Proteomics [creative-proteomics.com]
- 13. UWPR [proteomicsresource.washington.edu]
- 14. In-gel digestion samples | Tissue Imaging, Metabolomics and Proteomics Lab | Washington State University [labs.wsu.edu]
- 15. Preparation of Proteins and Peptides for Mass Spectrometry Analysis in a Bottom-Up Proteomics Workflow - PMC [pmc.ncbi.nlm.nih.gov]
- 16. Improvement of Automatic In-Gel Digestion by in Situ Alkylation of Proteins - PMC [pmc.ncbi.nlm.nih.gov]
- 17. Procedure for Reduction and Alkylation | Proteomics Facility - Carver College of Medicine | The University of Iowa [proteomics.medicine.uiowa.edu]
- 18. UCSF Mass Spectrometry Facility - Protocols In-Gel Digestion [msf.ucsf.edu]
- To cite this document: BenchChem. [how to improve the efficiency of in-gel digestion for mass spectrometry]. BenchChem, [2025]. [Online PDF]. Available at: [https://www.benchchem.com/product/b12398245#how-to-improve-the-efficiency-of-in-gel-digestion-for-mass-spectrometry]

---

### Disclaimer & Data Validity:

The information provided in this document is for Research Use Only (RUO) and is strictly not intended for diagnostic or therapeutic procedures. While BenchChem strives to provide accurate protocols, we make no warranties, express or implied, regarding the fitness of this product for every specific experimental setup.

**Technical Support:** The protocols provided are for reference purposes. Unsure if this reagent suits your experiment? [[Contact our Ph.D. Support Team for a compatibility check](#)]

**Need Industrial/Bulk Grade?** [Request Custom Synthesis Quote](#)

# BenchChem

Our mission is to be the trusted global source of essential and advanced chemicals, empowering scientists and researchers to drive progress in science and industry.

## Contact

Address: 3281 E Guasti Rd

Ontario, CA 91761, United States

Phone: (601) 213-4426

Email: [info@benchchem.com](mailto:info@benchchem.com)