

addressing batch-to-batch variability of synthetic Ageliferin

Author: BenchChem Technical Support Team. **Date:** December 2025

Compound of Interest

Compound Name: Ageliferin

Cat. No.: B1246841

[Get Quote](#)

Technical Support Center: Synthetic Ageliferin

This technical support center provides troubleshooting guidance and frequently asked questions (FAQs) for researchers, scientists, and drug development professionals working with synthetic **Ageliferin**. Our goal is to help you address potential issues, particularly batch-to-batch variability, to ensure the consistency and reliability of your experimental results.

Frequently Asked Questions (FAQs)

Q1: We are observing variable results in our biological assays with different batches of synthetic **Ageliferin**. What could be the cause?

A1: Batch-to-batch variability in synthetic **Ageliferin** can stem from several factors related to the chemical synthesis and purification process. These may include:

- **Purity Profile:** The presence of unreacted starting materials, intermediates, or side products can significantly alter the biological activity. Even small percentages of impurities can have agonistic or antagonistic effects.
- **Isomeric Content:** **Ageliferin** has multiple stereocenters, and different synthetic routes can produce varying ratios of diastereomers.^[1] Some isomers may be more biologically active than others.

- Residual Solvents and Salts: The purification process, often involving preparative HPLC with trifluoroacetic acid (TFA), can result in the final product being a salt (e.g., TFA salt).[1] The nature and amount of the counter-ion can influence the compound's solubility, stability, and ultimately its activity.
- Degradation: **Ageliferin** and its intermediates can be susceptible to degradation, such as oxidation, if not handled and stored properly.[1]

Q2: How can we assess the quality and consistency of our synthetic **Ageliferin** batches?

A2: A comprehensive analytical characterization is crucial for ensuring the quality and consistency of each batch. We recommend a panel of analytical tests to compare different batches.

Parameter	Recommended Analytical Method	Purpose
Identity	^1H NMR, ^{13}C NMR, High-Resolution Mass Spectrometry (HRMS)	Confirms the chemical structure of Ageliferin.
Purity	HPLC-UV, LC-MS/MS	Quantifies the percentage of Ageliferin and detects impurities.
Isomeric Ratio	Chiral HPLC, ^1H NMR	Determines the ratio of different stereoisomers.
Residual Solvents	Gas Chromatography (GC)	Quantifies any remaining solvents from the synthesis and purification.
Counter-ion Content	Ion Chromatography, NMR	Determines the amount of salt (e.g., TFA) present.

Illustrative Batch Comparison Data

Batch ID	Purity (HPLC, %)	Major Impurity (%)	Isomer Ratio (A:B)	Residual TFA (%)	Biological Activity (IC50, μM)
AG-2024-01	98.5	0.8	95:5	1.2	5.2
AG-2024-02	95.2	3.1	90:10	1.5	8.9
AG-2024-03	99.1	0.5	96:4	0.8	4.8

This table is for illustrative purposes only. Actual values may vary.

Q3: What are the best practices for handling and storing synthetic **Ageliferin** to minimize degradation?

A3: To ensure the stability and integrity of synthetic **Ageliferin**, follow these guidelines:

- **Storage:** Store in a tightly sealed vial, preferably under an inert atmosphere (e.g., argon or nitrogen), at -20°C or below.
- **Light and Air:** Protect from light and exposure to air to prevent photo-degradation and oxidation.
- **Dissolution:** Prepare solutions fresh for each experiment. If stock solutions are necessary, store them in small aliquots at -80°C to minimize freeze-thaw cycles. The choice of solvent can also impact stability; consult the literature for appropriate solvents.

Troubleshooting Guides

Problem 1: Low Yield or Incomplete Reaction During Synthesis

- **Possible Cause:** Impure reagents or solvents, incorrect reaction temperature, or insufficient mixing.
- **Troubleshooting Steps:**
 - Ensure all reagents and solvents are of high purity and anhydrous where necessary.

- Carefully monitor and control the reaction temperature at each step.
- Use appropriate stirring methods to ensure a homogenous reaction mixture.
- Consider that some intermediates in **Ageliferin** synthesis are prone to air oxidation, which can lower yields.[\[1\]](#)

Problem 2: Inconsistent Biological Activity Despite High Purity by HPLC

- Possible Cause: Presence of co-eluting impurities or biologically active isomers that are not resolved by your current HPLC method. The nature of the salt form (e.g., acetate vs. TFA salt) can also affect biological assays.[\[1\]](#)
- Troubleshooting Steps:
 - Develop an orthogonal HPLC method (e.g., different column, mobile phase) to screen for hidden impurities.
 - Use LC-MS/MS to identify the mass of any minor peaks.
 - Employ chiral HPLC to determine the isomeric composition of each batch.
 - If possible, standardize the salt form of **Ageliferin** across all batches.

Experimental Protocols

Protocol 1: High-Performance Liquid Chromatography (HPLC) for Purity Analysis

This protocol provides a general method for assessing the purity of synthetic **Ageliferin**. Method optimization may be required based on your specific instrumentation and the impurity profile of your material.

- Instrumentation: HPLC system with a UV detector.
- Column: C18 reverse-phase column (e.g., 4.6 x 150 mm, 5 μ m).
- Mobile Phase A: 0.1% Trifluoroacetic acid (TFA) in water.

- Mobile Phase B: 0.1% Trifluoroacetic acid (TFA) in acetonitrile.
- Gradient:
 - 0-5 min: 5% B
 - 5-25 min: 5% to 95% B
 - 25-30 min: 95% B
 - 30-35 min: 95% to 5% B
 - 35-40 min: 5% B
- Flow Rate: 1.0 mL/min.
- Detection: UV at 254 nm and 280 nm.
- Injection Volume: 10 μ L.
- Sample Preparation: Dissolve **Ageliferin** in a suitable solvent (e.g., methanol, DMSO) to a final concentration of 1 mg/mL.

Signaling Pathways and Experimental Workflows

Ageliferin's Biological Activity

Ageliferin is known for its antiviral and antimicrobial activities.^[1] While the precise molecular mechanisms are still under investigation, the diagrams below illustrate potential modes of action consistent with these biological effects.

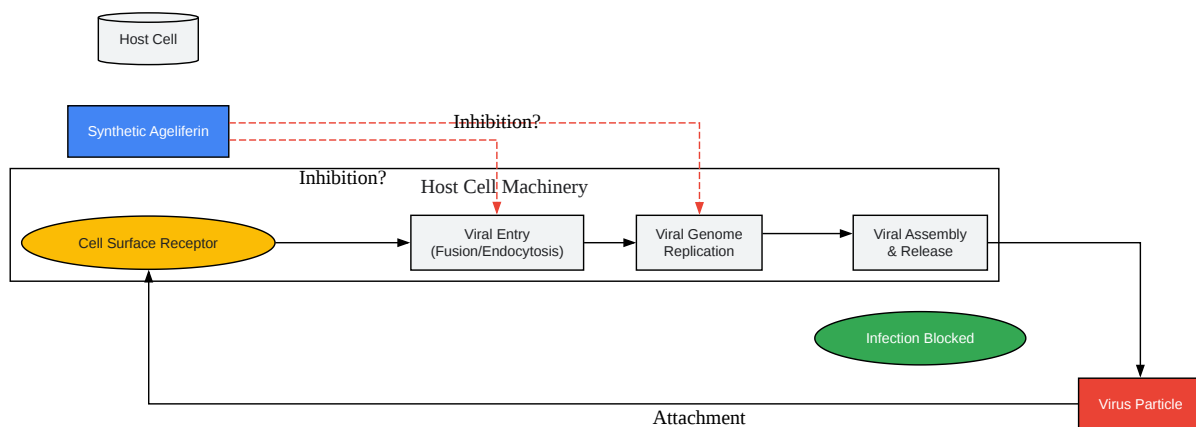

[Click to download full resolution via product page](#)

Caption: Potential antiviral mechanisms of action for **Ageliferin**.

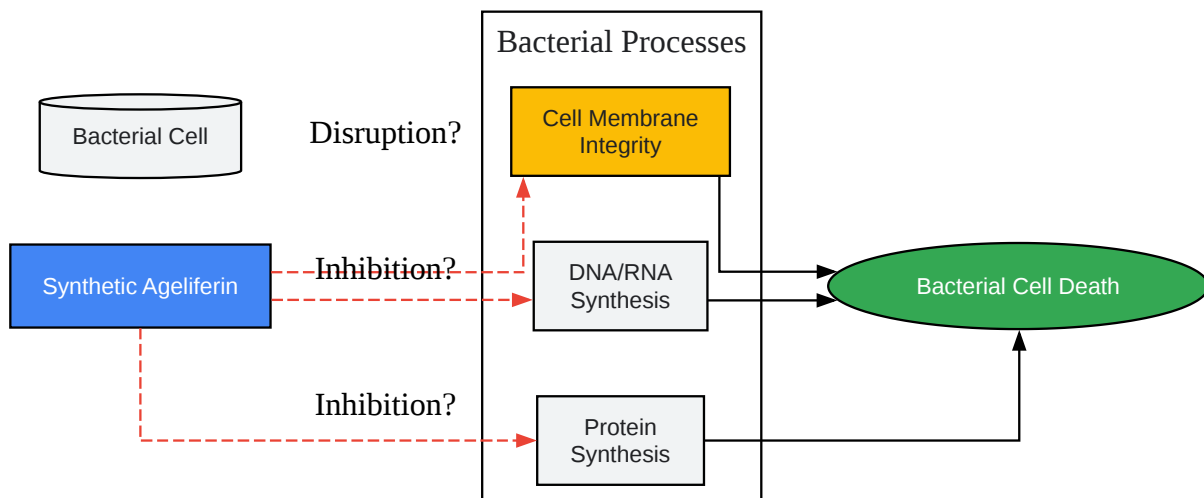

[Click to download full resolution via product page](#)

Caption: Potential antimicrobial mechanisms of action for **Ageliferin**.

Workflow for Investigating Batch-to-Batch Variability

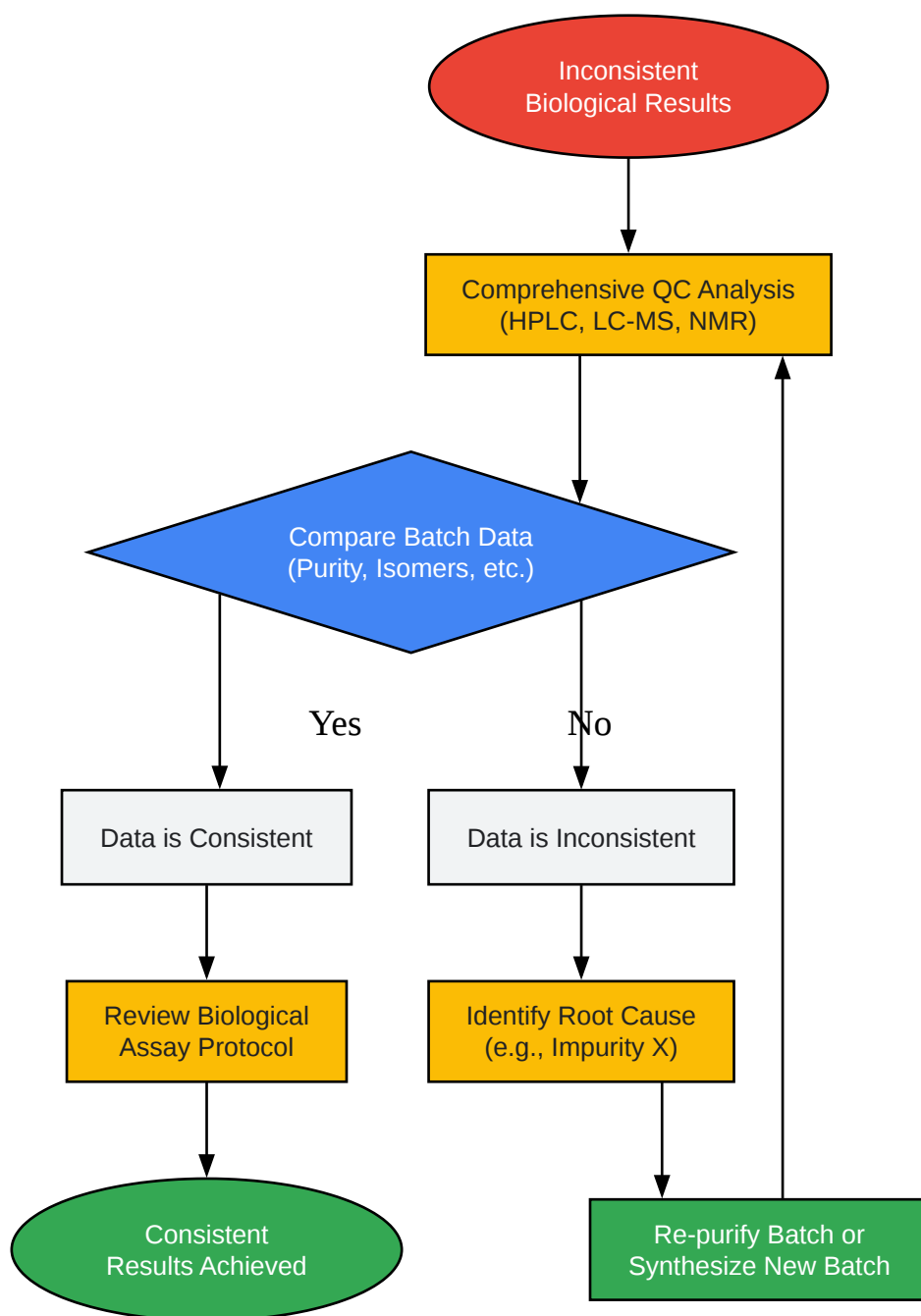

[Click to download full resolution via product page](#)

Caption: Logical workflow for troubleshooting batch-to-batch variability.

Need Custom Synthesis?

BenchChem offers custom synthesis for rare earth carbides and specific isotopic labeling.

Email: info@benchchem.com or [Request Quote Online](#).

References

- 1. Total Synthesis of Ageliferin via Acyl N-amidinylium Ion Rearrangement - PMC [pmc.ncbi.nlm.nih.gov]
- To cite this document: BenchChem. [addressing batch-to-batch variability of synthetic Ageliferin]. BenchChem, [2025]. [Online PDF]. Available at: [https://www.benchchem.com/product/b1246841#addressing-batch-to-batch-variability-of-synthetic-ageliferin]

Disclaimer & Data Validity:

The information provided in this document is for Research Use Only (RUO) and is strictly not intended for diagnostic or therapeutic procedures. While BenchChem strives to provide accurate protocols, we make no warranties, express or implied, regarding the fitness of this product for every specific experimental setup.

Technical Support: The protocols provided are for reference purposes. Unsure if this reagent suits your experiment? [[Contact our Ph.D. Support Team for a compatibility check](#)]

Need Industrial/Bulk Grade? [Request Custom Synthesis Quote](#)

BenchChem

Our mission is to be the trusted global source of essential and advanced chemicals, empowering scientists and researchers to drive progress in science and industry.

Contact

Address: 3281 E Guasti Rd
Ontario, CA 91761, United States
Phone: (601) 213-4426
Email: info@benchchem.com