

# Y08175 stability and storage best practices

**Author:** BenchChem Technical Support Team. **Date:** December 2025

## Compound of Interest

Compound Name: Y08175

Cat. No.: B12410146

[Get Quote](#)

## Technical Support Center: Y08175

This technical support center provides researchers, scientists, and drug development professionals with essential information on the stability and storage best practices for **Y08175**, a selective inhibitor of MEK1/2 kinases. Here you will find troubleshooting guides and frequently asked questions to ensure the successful application of **Y08175** in your experiments.

## Frequently Asked Questions (FAQs)

Q1: How should I store the lyophilized **Y08175** powder upon receipt?

A: Lyophilized **Y08175** is stable at room temperature for the duration of shipping.<sup>[1][2]</sup> Upon receipt, it is recommended to store the powder at -20°C for long-term stability.<sup>[1][3]</sup> The lyophilized powder, when stored correctly, is stable for up to three years.<sup>[1][3]</sup> Before opening, centrifuge the vial to ensure all the powder is collected at the bottom.<sup>[1]</sup>

Q2: What is the recommended solvent for reconstituting **Y08175**?

A: The recommended solvent for creating a stock solution of **Y08175** is high-quality, anhydrous dimethyl sulfoxide (DMSO).<sup>[2][4]</sup> **Y08175** is highly soluble in DMSO. For most in vitro experiments, a stock solution of 10 mM can be prepared.<sup>[5][6]</sup>

Q3: How should I store the reconstituted stock solution of **Y08175**?

A: Once reconstituted in DMSO, the stock solution should be aliquoted into small, single-use volumes to avoid repeated freeze-thaw cycles, which can degrade the compound.<sup>[1][7]</sup> These

aliquots should be stored in tightly sealed vials at -80°C for long-term storage (up to 6 months) or at -20°C for shorter-term storage (up to one month).[1] When you need to use the compound, bring a single aliquot to room temperature before opening to prevent condensation from introducing moisture.[8]

Q4: Is **Y08175** sensitive to light?

A: While **Y08175** is not known to be exceptionally light-sensitive, it is good practice to store stock solutions in amber vials or vials wrapped in foil to protect them from light, as prolonged exposure can lead to degradation of some small molecules.[7][9]

Q5: What is the stability of **Y08175** in aqueous cell culture media?

A: The stability of small molecule inhibitors can be limited in aqueous solutions.[2] It is recommended to prepare fresh dilutions of **Y08175** in your experimental media from a DMSO stock solution for each experiment.[7] Do not store **Y08175** in aqueous solutions for extended periods. The final concentration of DMSO in the cell culture media should typically be kept below 0.5% to avoid solvent-induced toxicity.[7]

## Table 1: Storage and Stability Summary for Y08175

Form	Recommended Storage Temperature	Shelf Life	Key Considerations
Lyophilized Powder	-20°C	≤ 3 years	Store in a desiccator; centrifuge vial before opening.[1][10]
DMSO Stock Solution	-80°C	≤ 6 months	Aliquot into single-use volumes to avoid freeze-thaw cycles.[1]
DMSO Stock Solution	-20°C	≤ 1 month	Suitable for short-term storage of aliquots.[1]
Aqueous Solution	2-8°C	< 24 hours	Prepare fresh for each experiment; not recommended for storage.[2][6]

## Troubleshooting Guides

Q1: I am not observing the expected inhibitory effect of **Y08175** on the MAPK/ERK pathway. What could be the cause?

A: Several factors could contribute to a lack of efficacy. Consider the following troubleshooting steps:

- **Compound Degradation:** Ensure that the stock solution has been stored correctly and has not undergone multiple freeze-thaw cycles.[1][7] It is advisable to use a fresh aliquot of the inhibitor.
- **Incorrect Concentration:** Verify the calculations for your serial dilutions. It is also possible that the compound is not fully dissolved at the tested concentrations.[7]
- **Cellular Context:** Ensure that the cell line you are using has a constitutively active or inducible MAPK/ERK pathway. The inhibitor's effect is dependent on the pathway being active.

- Assay Variability: Standardize all experimental parameters, including incubation times and reagent concentrations, as small variations can lead to different outcomes.[7]

Q2: My experimental results with **Y08175** are not reproducible. What are some potential reasons?

A: Lack of reproducibility is a common issue in in vitro experiments.[7] Potential causes include:

- Inconsistent Cell Culture Practices: Use cells of a consistent passage number and confluency, as their response to inhibitors can vary with their state.[7]
- Inconsistent Compound Handling: Always prepare fresh dilutions from a new aliquot for each experiment to rule out compound instability in the media.[7]
- Solvent Effects: Ensure the final concentration of DMSO is consistent across all experiments, including the vehicle control, as high concentrations can be toxic.[7]

## Table 2: Common Troubleshooting Scenarios for Y08175

Issue	Possible Cause	Recommended Action
No biological effect observed	Compound degradation, incorrect concentration, or inactive pathway.	Use a fresh aliquot of Y08175, verify dilution calculations, and confirm pathway activity in your cell model with a positive control. <a href="#">[7]</a>
High variability between experiments	Inconsistent cell culture or compound handling.	Standardize cell passage number and confluency. Always use fresh dilutions of Y08175 and maintain a consistent final DMSO concentration. <a href="#">[7]</a>
Unexpected cellular toxicity	Off-target effects or high DMSO concentration.	Perform a dose-response curve to find the minimal effective concentration. Ensure the final DMSO concentration is below 0.5%. <a href="#">[7]</a> <a href="#">[11]</a>
Compound precipitates in media	Poor solubility at the working concentration.	Prepare serial dilutions in DMSO before adding to the aqueous medium. Visually inspect for precipitation. If necessary, lower the final concentration. <a href="#">[2]</a>

## Experimental Protocols

### Protocol 1: Assessment of Y08175 Purity and Stability by HPLC

This protocol outlines a method to assess the purity of **Y08175** and monitor its stability over time under different storage conditions.

Methodology:

- Sample Preparation:

- Prepare a 1 mg/mL solution of **Y08175** in acetonitrile.
- For stability testing, store aliquots of the stock solution under various conditions (e.g., -80°C, -20°C, 4°C, and room temperature).
- At specified time points (e.g., 0, 1, 3, and 6 months), retrieve an aliquot and dilute it to the working concentration.[12]
- HPLC Conditions:
  - Column: C18 reverse-phase column (e.g., 4.6 x 150 mm, 5 µm).
  - Mobile Phase A: 0.1% formic acid in water.
  - Mobile Phase B: 0.1% formic acid in acetonitrile.
  - Gradient: Start with 95% A and 5% B, ramp to 100% B over 15 minutes, hold for 5 minutes, then return to initial conditions.
  - Flow Rate: 1.0 mL/min.
  - Detection: UV at 254 nm.
- Data Analysis:
  - Integrate the peak area of **Y08175** and any degradation products.
  - Calculate the purity of **Y08175** at each time point as a percentage of the total peak area.
  - A significant decrease in the main peak area and the appearance of new peaks indicate degradation.[12]

## Protocol 2: In Vitro Kinase Assay to Measure **Y08175** Activity

This protocol describes a method to determine the functional activity of **Y08175** by measuring its ability to inhibit MEK1 kinase activity.

### Methodology:

- Reagent Preparation:
  - Prepare a reaction buffer (e.g., 25 mM HEPES, pH 7.5, 10 mM MgCl<sub>2</sub>, 1 mM DTT).
  - Dilute recombinant active MEK1 kinase and its substrate (e.g., inactive ERK2) in the reaction buffer.
  - Prepare a serial dilution of **Y08175** in DMSO and then dilute further in the reaction buffer.
- Kinase Reaction:
  - In a 96-well plate, add the MEK1 kinase, the **Y08175** dilution (or DMSO vehicle control), and let it incubate for 15 minutes at room temperature.
  - Initiate the reaction by adding the ERK2 substrate and ATP.
  - Allow the reaction to proceed for 30 minutes at 30°C.
- Detection:
  - Terminate the reaction by adding a stop solution (e.g., EDTA).
  - Measure the amount of phosphorylated ERK2 using a suitable detection method, such as a phospho-specific antibody in an ELISA format or a luminescence-based assay that measures the remaining ATP.
- Data Analysis:
  - Plot the percentage of kinase inhibition against the logarithm of the **Y08175** concentration.
  - Fit the data to a dose-response curve to determine the IC<sub>50</sub> value.

## Visualizations

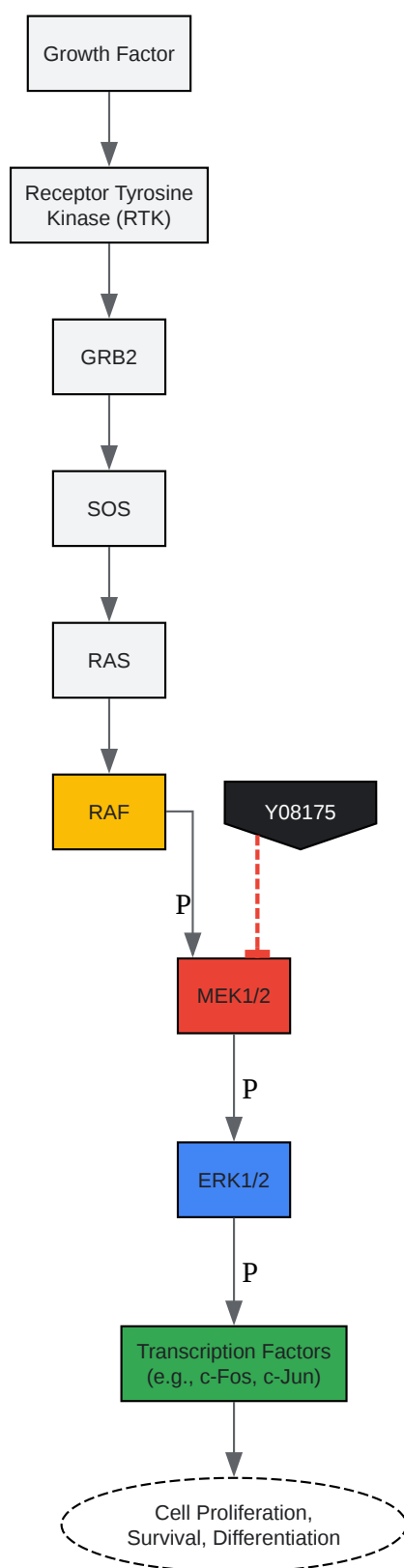

[Click to download full resolution via product page](#)

Caption: The MAPK/ERK signaling pathway with the inhibitory action of **Y08175** on MEK1/2.



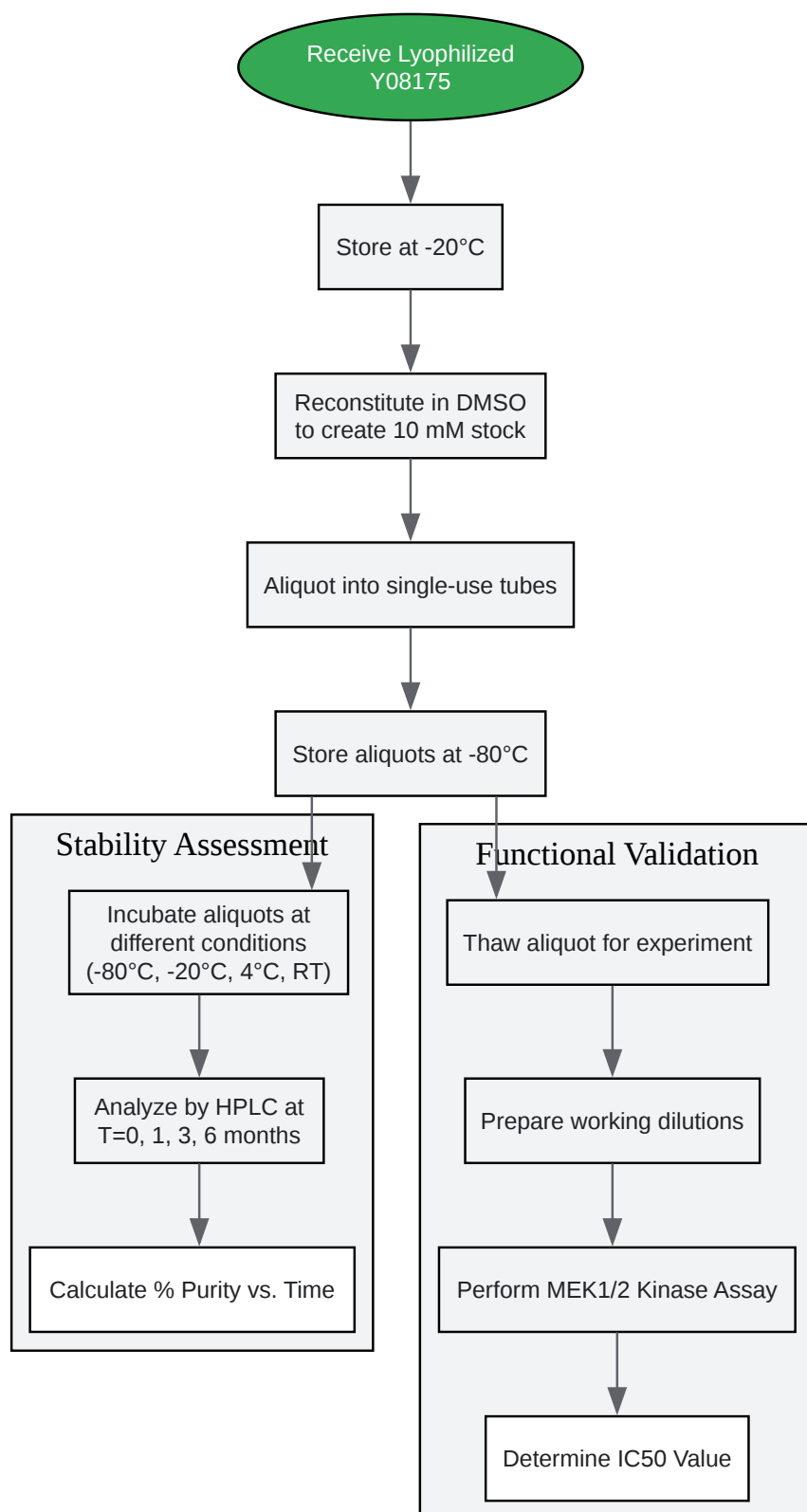

[Click to download full resolution via product page](#)

### Need Custom Synthesis?

BenchChem offers custom synthesis for rare earth carbides and specific isotopic labeling.

Email: [info@benchchem.com](mailto:info@benchchem.com) or [Request Quote Online](#).

## References

- 1. [captivatebio.com](http://captivatebio.com) [[captivatebio.com](http://captivatebio.com)]
- 2. [FAQs on Inhibitor Preparation](#) [[sigmaaldrich.cn](http://sigmaaldrich.cn)]
- 3. [file.selleckchem.com](http://file.selleckchem.com) [[file.selleckchem.com](http://file.selleckchem.com)]
- 4. Protocol to identify small-molecule inhibitors against cancer drug resistance - PMC [[pmc.ncbi.nlm.nih.gov](http://pmc.ncbi.nlm.nih.gov)]
- 5. [researchgate.net](http://researchgate.net) [[researchgate.net](http://researchgate.net)]
- 6. AN OPTIMIZED SMALL MOLECULE INHIBITOR COCKTAIL SUPPORTS LONG-TERM MAINTENANCE OF HUMAN EMBRYONIC STEM CELLS - PMC [[pmc.ncbi.nlm.nih.gov](http://pmc.ncbi.nlm.nih.gov)]
- 7. [benchchem.com](http://benchchem.com) [[benchchem.com](http://benchchem.com)]
- 8. [researchgate.net](http://researchgate.net) [[researchgate.net](http://researchgate.net)]
- 9. [sigmaaldrich.com](http://sigmaaldrich.com) [[sigmaaldrich.com](http://sigmaaldrich.com)]
- 10. [nbinno.com](http://nbinno.com) [[nbinno.com](http://nbinno.com)]
- 11. [benchchem.com](http://benchchem.com) [[benchchem.com](http://benchchem.com)]
- 12. How to Conduct Stability Studies for Small Molecule Drugs – [StabilityStudies.in](http://StabilityStudies.in) [[stabilitystudies.in](http://stabilitystudies.in)]
- To cite this document: BenchChem. [Y08175 stability and storage best practices]. BenchChem, [2025]. [Online PDF]. Available at: [<https://www.benchchem.com/product/b12410146#y08175-stability-and-storage-best-practices>]

---

### Disclaimer & Data Validity:

The information provided in this document is for Research Use Only (RUO) and is strictly not intended for diagnostic or therapeutic procedures. While BenchChem strives to provide

accurate protocols, we make no warranties, express or implied, regarding the fitness of this product for every specific experimental setup.

**Technical Support:** The protocols provided are for reference purposes. Unsure if this reagent suits your experiment? [[Contact our Ph.D. Support Team for a compatibility check](#)]

**Need Industrial/Bulk Grade?** [Request Custom Synthesis Quote](#)

## BenchChem

Our mission is to be the trusted global source of essential and advanced chemicals, empowering scientists and researchers to drive progress in science and industry.

### Contact

Address: 3281 E Guasti Rd

Ontario, CA 91761, United States

Phone: (601) 213-4426

Email: [info@benchchem.com](mailto:info@benchchem.com)