

Whitepaper: The Anti-Glioblastoma Potential of Honokiol

Author: BenchChem Technical Support Team. **Date:** December 2025

Compound of Interest

Compound Name: *Smyrindiol*

Cat. No.: *B15576944*

[Get Quote](#)

A Technical Guide for Researchers and Drug Development Professionals

Disclaimer: Initial literature searches for "**Smyrindiol**" and its effects on glioblastoma cell lines did not yield any available scientific data. Therefore, this technical guide has been developed using Honokiol, a well-researched natural compound with demonstrated anti-glioblastoma properties, as a representative molecule to fulfill the structural and content requirements of the original request.

Executive Summary

Glioblastoma (GBM) remains one of the most aggressive and challenging-to-treat primary brain tumors. The relentless search for novel therapeutic agents has led to the investigation of various natural compounds. Honokiol, a biphenolic compound isolated from the bark of Magnolia species, has emerged as a promising candidate. It is capable of crossing the blood-brain barrier and has demonstrated significant anti-tumor activity in multiple glioblastoma cell lines. This document provides a comprehensive technical overview of the effects of Honokiol on glioblastoma cells, focusing on its impact on cell viability, apoptosis, and the underlying molecular signaling pathways. All data is presented to facilitate further research and development in the field of neuro-oncology.

Data Presentation: Quantitative Effects of Honokiol on Glioblastoma Cell Lines

The following tables summarize the quantitative data on the efficacy of Honokiol in various glioblastoma cell lines.

Table 1: IC50 Values of Honokiol in Glioblastoma Cell Lines

| Cell Line | IC50 Value (µM) | Treatment Duration (hours) | Assay Method | Reference |
|----------------------|---|----------------------------|------------------|-----------|
| U251 | 54 | 24 | MTT | [1][2] |
| U-87 MG | 62.5 | 24 | MTT | [1][2] |
| DBTRG-05MG | ~30 | 72 | Sulforhodamine B | [3] |
| T98G | Not specified, but cytotoxic effects observed at ≥ 10 µM | 24, 48, 72 | MTT | [4] |
| 9L (rat gliosarcoma) | 15.61 µg/mL (~47 µM) | 24 | Not specified | [5] |
| U251 | 16.38 µg/mL (~49 µM) | 24 | Not specified | [5] |

Table 2: Pro-Apoptotic Effects of Honokiol on Glioblastoma Cell Lines

| Cell Line | Honokiol Concentration (μM) | Observation | Method | Reference |
|----------------|--|---|----------------|-----------|
| T98G | ≥ 10 | Significant increase in TUNEL-positive cells | TUNEL Assay | [4] |
| T98G | ≥ 10 | Increased Bax/Bcl-2 ratio | Western Blot | [4] |
| DBTRG-05MG | 50 | Cleavage of PARP and Bcl-xL | Western Blot | [6] |
| DBTRG-05MG | 50 | 53.55% of cells in sub-G1 phase | Flow Cytometry | [3] |
| U251 & U-87 MG | 20, 40, 60 | Dose-dependent increase in Annexin V-positive cells | Flow Cytometry | [1][7] |
| U251 & U-87 MG | 20, 40, 60 | Increased cleaved caspase-3 | Western Blot | [1][7] |
| U251 & U-87 MG | 20, 40, 60 | Decreased Bcl-2, Increased Bax | Western Blot | [1][7] |

Experimental Protocols

This section details the methodologies for key experiments cited in the literature regarding Honokiol's effects on glioblastoma cells.

Cell Culture

- Cell Lines: U251, U-87 MG, T98G, and DBTRG-05MG human glioblastoma cell lines are commonly used.

- **Culture Medium:** Cells are typically cultured in Dulbecco's Modified Eagle Medium (DMEM) supplemented with 10% Fetal Bovine Serum (FBS) and 1% penicillin/streptomycin solution.
- **Culture Conditions:** Cells are maintained in a humidified incubator at 37°C with a 5% CO₂ atmosphere.
- **Subculturing:** Cells are passaged upon reaching 80-90% confluency.

Cell Viability Assay (MTT Assay)

- **Seeding:** Glioblastoma cells are seeded into 96-well plates at a density of 5×10^3 to 1×10^4 cells per well and allowed to adhere overnight.
- **Treatment:** The culture medium is replaced with fresh medium containing various concentrations of Honokiol (e.g., 0, 10, 20, 40, 60 μ M) or vehicle control (DMSO).
- **Incubation:** Cells are incubated for specified durations (e.g., 24, 48, or 72 hours).
- **MTT Addition:** 20 μ L of MTT solution (5 mg/mL in PBS) is added to each well, and the plate is incubated for an additional 4 hours at 37°C.
- **Formazan Solubilization:** The medium is removed, and 150 μ L of DMSO is added to each well to dissolve the formazan crystals.
- **Absorbance Measurement:** The absorbance is measured at 490 nm using a microplate reader.
- **Data Analysis:** Cell viability is expressed as a percentage of the vehicle-treated control. The IC₅₀ value is calculated from the dose-response curve.

Apoptosis Analysis by Annexin V/PI Staining and Flow Cytometry

- **Cell Treatment:** Cells are seeded in 6-well plates and treated with varying concentrations of Honokiol for the desired time.
- **Cell Harvesting:** Both floating and adherent cells are collected, washed with ice-cold PBS, and centrifuged.

- **Staining:** The cell pellet is resuspended in 1X Binding Buffer. Annexin V-FITC and Propidium Iodide (PI) are added according to the manufacturer's protocol, and the cells are incubated in the dark for 15 minutes at room temperature.
- **Flow Cytometry:** The stained cells are analyzed using a flow cytometer. Annexin V-positive/PI-negative cells are considered early apoptotic, while Annexin V-positive/PI-positive cells are considered late apoptotic or necrotic.

Western Blot Analysis

- **Protein Extraction:** After treatment with Honokiol, cells are washed with PBS and lysed in RIPA buffer containing protease and phosphatase inhibitors.
- **Protein Quantification:** The total protein concentration of the lysates is determined using a BCA protein assay.
- **SDS-PAGE:** Equal amounts of protein (e.g., 20-40 μg) are separated by sodium dodecyl sulfate-polyacrylamide gel electrophoresis.
- **Protein Transfer:** The separated proteins are transferred to a polyvinylidene difluoride (PVDF) membrane.
- **Blocking:** The membrane is blocked with 5% non-fat milk or bovine serum albumin (BSA) in Tris-buffered saline with Tween 20 (TBST) for 1 hour at room temperature.
- **Primary Antibody Incubation:** The membrane is incubated overnight at 4°C with primary antibodies targeting proteins of interest (e.g., EGFR, p-STAT3, p-Akt, Bcl-2, Bax, cleaved caspase-3, GAPDH).
- **Secondary Antibody Incubation:** The membrane is washed with TBST and incubated with a horseradish peroxidase (HRP)-conjugated secondary antibody for 1 hour at room temperature.
- **Detection:** The protein bands are visualized using an enhanced chemiluminescence (ECL) detection system.

Visualization of Signaling Pathways and Workflows

Signaling Pathways Modulated by Honokiol in Glioblastoma

Honokiol has been shown to interfere with several critical signaling pathways that promote glioblastoma cell survival and proliferation.[7][8][9] The primary mechanisms involve the inhibition of the EGFR/JAK/STAT3 and PI3K/Akt/mTOR pathways.

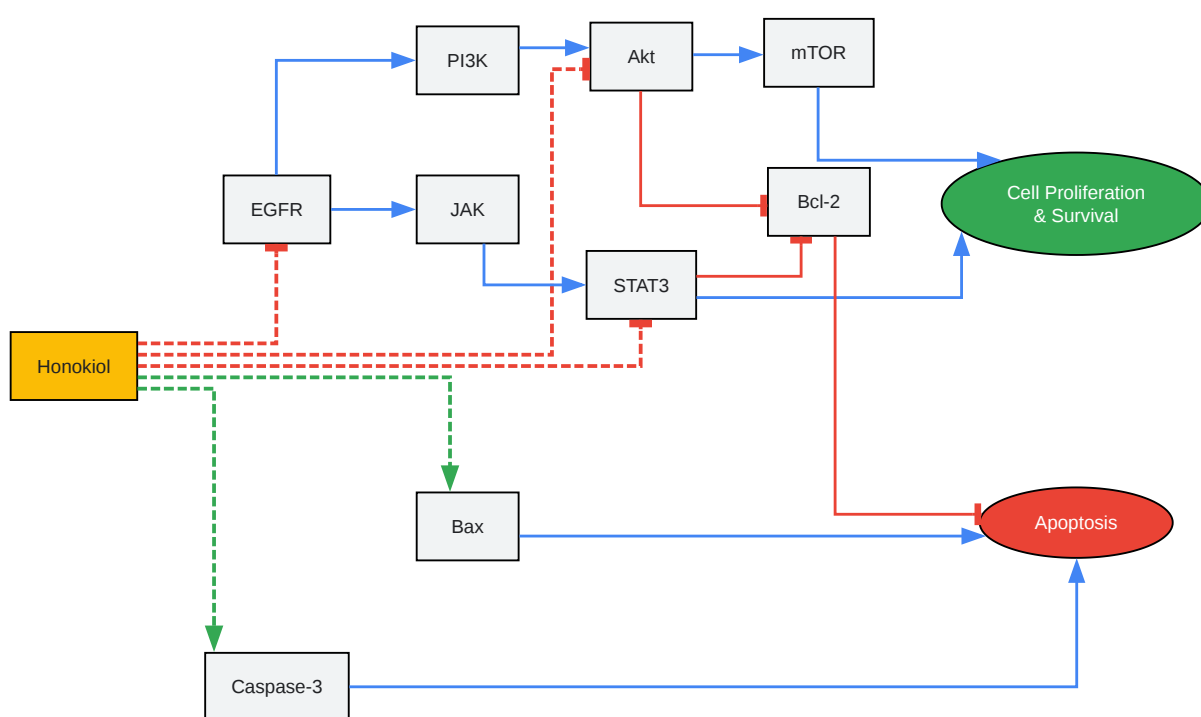

[Click to download full resolution via product page](#)

Figure 1. Honokiol inhibits key pro-survival pathways in glioblastoma cells.

Experimental Workflow for Assessing Honokiol's Anti-Cancer Effects

The following diagram illustrates a typical workflow for evaluating the efficacy of a compound like Honokiol against glioblastoma cell lines in vitro.

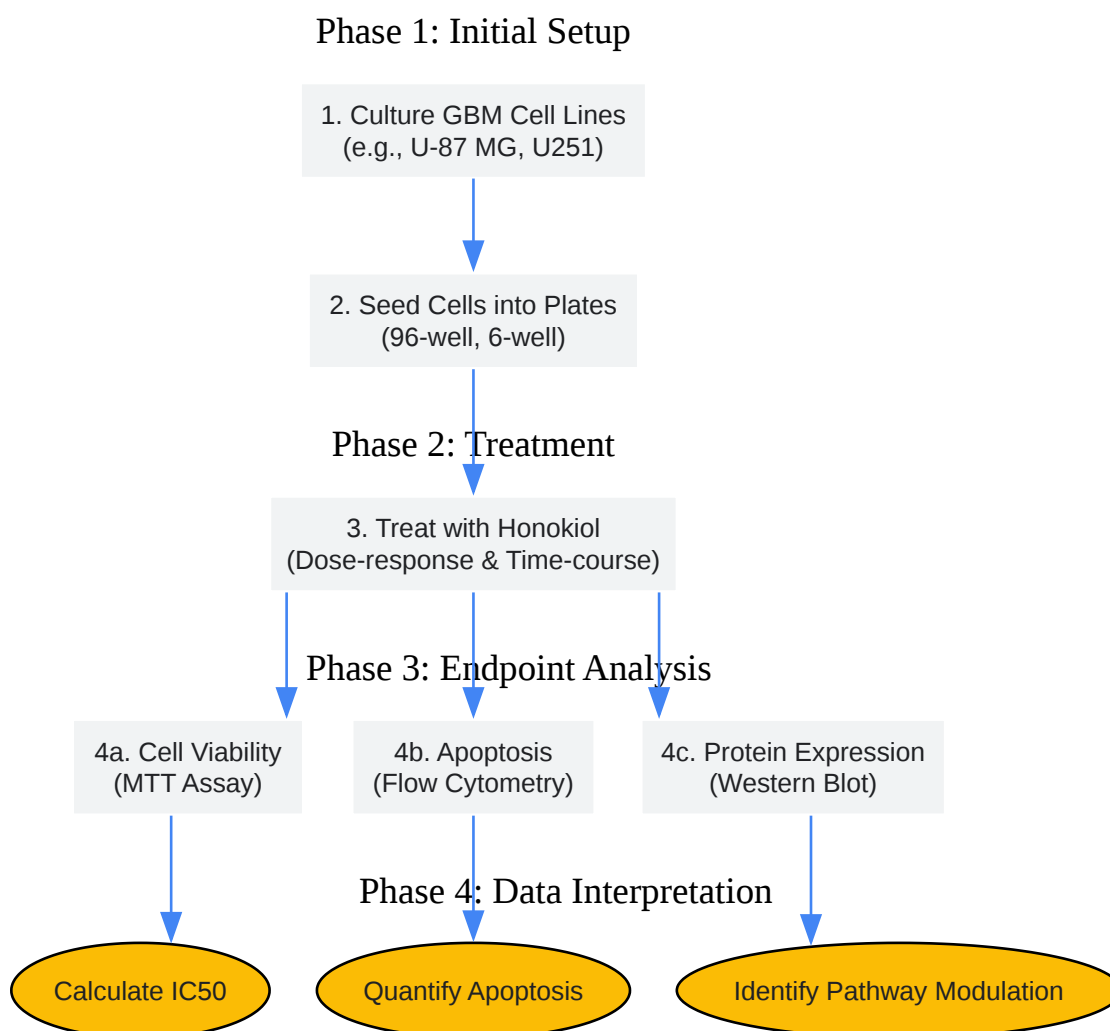

[Click to download full resolution via product page](#)

Figure 2. A generalized workflow for in vitro evaluation of Honokiol.

Conclusion and Future Directions

The data compiled in this guide strongly indicates that Honokiol is a potent inhibitor of glioblastoma cell growth and survival in vitro. Its ability to induce apoptosis and concurrently inhibit multiple critical signaling pathways, such as EGFR/JAK/STAT3 and PI3K/Akt, highlights

its potential as a multi-targeted therapeutic agent. Furthermore, its capacity to cross the blood-brain barrier is a crucial advantage for treating central nervous system malignancies.

Future research should focus on:

- In vivo studies using orthotopic glioblastoma models to validate the in vitro efficacy.
- Investigating potential synergistic effects when combined with standard-of-care treatments like temozolomide and radiation.
- Exploring the development of novel drug delivery systems, such as liposomal formulations, to enhance the bioavailability and targeted delivery of Honokiol to the tumor site.[10][11]
- Further elucidation of its impact on other cellular processes, such as autophagy and ferroptosis, which have also been implicated in its mechanism of action.[6][12]

Need Custom Synthesis?

BenchChem offers custom synthesis for rare earth carbides and specific isotopic labeling.

Email: info@benchchem.com or [Request Quote Online](#).

References

- 1. researchgate.net [researchgate.net]
- 2. researchgate.net [researchgate.net]
- 3. Honokiol-induced apoptosis and autophagy in glioblastoma multiforme cells - PMC [pmc.ncbi.nlm.nih.gov]
- 4. spandidos-publications.com [spandidos-publications.com]
- 5. Honokiol Crosses BBB and BCSFB, and Inhibits Brain Tumor Growth in Rat 9L Intracerebral Gliosarcoma Model and Human U251 Xenograft Glioma Model - PMC [pmc.ncbi.nlm.nih.gov]
- 6. Honokiol-induced apoptosis and autophagy in glioblastoma multiforme cells - PubMed [pubmed.ncbi.nlm.nih.gov]
- 7. Honokiol Eliminates Glioma/Glioblastoma Stem Cell-Like Cells via JAK-STAT3 Signaling and Inhibits Tumor Progression by Targeting Epidermal Growth Factor Receptor - PMC

[pmc.ncbi.nlm.nih.gov]

- 8. Honokiol Eliminates Glioma/Glioblastoma Stem Cell-Like Cells Via JAK-STAT3 Signaling and Inhibits Tumor Progression by Targeting Epidermal Growth Factor Receptor - PubMed [pubmed.ncbi.nlm.nih.gov]
- 9. Honokiol mediated inhibition of PI3K/mTOR pathway: A potential strategy to overcome immunoresistance in glioma, breast and prostate carcinoma without impacting T cell function - PMC [pmc.ncbi.nlm.nih.gov]
- 10. Liposomal honokiol enhance the anti-tumor effect of bevacizumab in glioblastoma by inhibiting autophagy - PMC [pmc.ncbi.nlm.nih.gov]
- 11. Liposomal honokiol inhibits glioblastoma growth through regulating macrophage polarization - Li - Annals of Translational Medicine [atm.amegroups.org]
- 12. researchgate.net [researchgate.net]
- To cite this document: BenchChem. [Whitepaper: The Anti-Glioblastoma Potential of Honokiol]. BenchChem, [2025]. [Online PDF]. Available at: [https://www.benchchem.com/product/b15576944#smyrindiol-and-its-effects-on-glioblastoma-cell-lines]

Disclaimer & Data Validity:

The information provided in this document is for Research Use Only (RUO) and is strictly not intended for diagnostic or therapeutic procedures. While BenchChem strives to provide accurate protocols, we make no warranties, express or implied, regarding the fitness of this product for every specific experimental setup.

Technical Support: The protocols provided are for reference purposes. Unsure if this reagent suits your experiment? [[Contact our Ph.D. Support Team for a compatibility check](#)]

Need Industrial/Bulk Grade? [Request Custom Synthesis Quote](#)

BenchChem

Our mission is to be the trusted global source of essential and advanced chemicals, empowering scientists and researchers to drive progress in science and industry.

Contact

Address: 3281 E Guasti Rd

Ontario, CA 91761, United States

Phone: (601) 213-4426

Email: info@benchchem.com