

# Variability in MAP17 expression in different cell passages

**Author:** BenchChem Technical Support Team. **Date:** December 2025

## Compound of Interest

Compound Name: MAP17

Cat. No.: B15597279

[Get Quote](#)

## Technical Support Center: MAP17 Expression

This technical support center provides troubleshooting guides and frequently asked questions (FAQs) for researchers, scientists, and drug development professionals working with the **MAP17** protein.

### Frequently Asked Questions (FAQs)

Q1: What is **MAP17** and what is its primary function?

**MAP17**, also known as PDZK1IP1, is a small, non-glycosylated membrane-associated protein.<sup>[1][2]</sup> It is primarily localized to the plasma membrane and the Golgi apparatus.<sup>[1][3]</sup> **MAP17** acts as a cargo protein, interacting with PDZ domain-containing proteins to facilitate the transport of various molecules across the plasma membrane.<sup>[2]</sup> It is involved in regulating cellular processes such as proliferation, apoptosis, and tumorigenesis.<sup>[1]</sup>

Q2: What is the role of **MAP17** in cancer?

**MAP17** is overexpressed in a wide variety of human carcinomas, including those of the breast, cervix, colon, lung, ovary, and prostate.<sup>[1][4][5][6]</sup> Its overexpression is strongly correlated with tumor progression and a more dedifferentiated phenotype.<sup>[1][4]</sup> High levels of **MAP17** are associated with increased malignant characteristics, such as enhanced proliferation, invasion, and resistance to certain drugs.<sup>[1][7][8]</sup> **MAP17** is also implicated in the regulation of cancer stem cells.<sup>[1][7]</sup>

Q3: How does **MAP17** exert its effects on cancer cells?

**MAP17** influences several signaling pathways to promote tumorigenesis. It can activate the Notch pathway by interacting with NUMB, leading to an increase in stem cell factors.[1][9] Additionally, **MAP17** can induce the production of reactive oxygen species (ROS), which in turn activates the PI3K/AKT signaling pathway, protecting cells from apoptosis.[3][7][10] **MAP17** has also been shown to be involved in the activation of p53 and Wnt signaling pathways.[2][11]

## Variability in **MAP17** Expression in Different Cell Passages

Currently, there is limited specific quantitative data available in the public domain that details the variability of **MAP17** expression across different cell passages. However, it is a well-established principle in cell culture that the characteristics of cell lines, including gene and protein expression, can change over time with increasing passage number.

General Factors Affecting Protein Expression in Continuous Cell Culture:

Several factors can contribute to the variability of protein expression during continuous cell culture:

- **Genetic Drift and Clonal Selection:** Continuous passaging can lead to the selection of subpopulations of cells with different growth advantages, which may also have altered expression levels of certain proteins.
- **Senescence:** As primary and some continuous cell lines approach senescence, their gene expression profiles can change significantly.
- **Culture Conditions:** Variations in media composition, serum quality, cell density, and passaging schedule can all impact protein expression.[12][13]
- **Cell Line Misidentification and Cross-Contamination:** Using misidentified or cross-contaminated cell lines is a significant problem in biomedical research and can lead to erroneous and irreproducible results.[6][14][15][16][17] It is crucial to authenticate cell lines regularly.

Recommendations:

- **Low Passage Numbers:** For critical experiments, it is advisable to use cells at the lowest passage number possible.
- **Consistent Culture Practices:** Maintain consistent cell culture conditions, including media, supplements, and passaging protocols.
- **Regular Authentication:** Regularly authenticate your cell lines using methods like Short Tandem Repeat (STR) profiling.
- **Monitor Expression:** If **MAP17** expression is a critical parameter in your experiments, it is recommended to monitor its expression levels (e.g., by qPCR or Western blot) at different passage numbers to ensure consistency.

## Troubleshooting Guides

### Western Blotting for MAP17

Problem	Possible Cause	Troubleshooting Steps
No or Weak Signal	Insufficient protein loading.	Ensure at least 20-30 µg of total protein is loaded per lane. <a href="#">[11]</a> Use a protein assay to accurately quantify protein concentration.
Low MAP17 expression in the cell line.	Confirm MAP17 expression in your cell line using qPCR or by consulting literature. <a href="#">[18]</a> <a href="#">[19]</a> Use a positive control cell line known to express MAP17.	
Inefficient protein transfer.	Verify transfer efficiency by staining the membrane with Ponceau S. <a href="#">[9]</a> <a href="#">[20]</a> Optimize transfer time and voltage, especially for a small protein like MAP17 (17 kDa).	
Primary antibody issue.	Use a primary antibody validated for Western blotting. Optimize antibody concentration and incubation time (e.g., overnight at 4°C). <a href="#">[5]</a> <a href="#">[11]</a>	
Inactive secondary antibody or substrate.	Use a fresh secondary antibody and substrate. Confirm enzyme activity of HRP-conjugated secondaries. <a href="#">[20]</a>	
High Background	Insufficient blocking.	Increase blocking time (e.g., 1-2 hours at room temperature) or try a different blocking agent (e.g., 5% non-fat milk or BSA). <a href="#">[21]</a> <a href="#">[22]</a>

---

Primary or secondary antibody concentration too high.	Decrease the antibody concentrations and/or reduce incubation times. <a href="#">[9]</a> <a href="#">[22]</a>	
Insufficient washing.	Increase the number and duration of wash steps with a buffer containing a detergent like Tween 20. <a href="#">[9]</a> <a href="#">[20]</a>	
Non-specific Bands	Protein degradation.	Prepare fresh cell lysates and always include protease inhibitors in the lysis buffer. <a href="#">[11]</a>
Antibody cross-reactivity.	Use a more specific primary antibody. If possible, use a negative control (e.g., lysate from cells with MAP17 knocked down).	
Too much protein loaded.	Reduce the amount of protein loaded per lane. <a href="#">[11]</a>	

---

## Quantitative PCR (qPCR) for MAP17

Problem	Possible Cause	Troubleshooting Steps
No or Low Amplification	Poor RNA quality or integrity.	Use a robust RNA extraction method and check RNA integrity (e.g., using a Bioanalyzer).
Inefficient reverse transcription.	Optimize the reverse transcription reaction. Use high-quality reverse transcriptase and appropriate primers (oligo(dT) or random hexamers).[2]	
Suboptimal primer design.	Design and validate primers for specificity and efficiency. Ensure they span an exon-exon junction to avoid amplifying genomic DNA.	
Incorrect annealing temperature.	Perform a temperature gradient qPCR to determine the optimal annealing temperature for your primers. [23]	
High Cq Values	Low target abundance.	Increase the amount of cDNA template in the reaction.
PCR inhibition.	Ensure RNA and cDNA samples are free of inhibitors from the extraction process.	
Poor Amplification Efficiency	Suboptimal reaction conditions.	Optimize primer and MgCl <sub>2</sub> concentrations. Ensure the qPCR master mix is fresh and properly stored.
Primer-dimer formation.	Analyze the melt curve for a single peak corresponding to	

the specific product. Redesign primers if necessary.

---

Inconsistent Replicates

Pipetting errors.

Use calibrated pipettes and ensure accurate and consistent pipetting. Prepare a master mix for all reactions.

[\[24\]](#)

---

DNA contamination.

Use a no-template control (NTC) to check for contamination in your reagents.[\[23\]](#)

---

## Immunofluorescence (IF) for MAP17

Problem	Possible Cause	Troubleshooting Steps
No or Weak Signal	Low MAP17 expression.	Choose a cell line known to express MAP17. Confirm expression by Western blot or qPCR.
Inappropriate fixation.	Test different fixation methods (e.g., paraformaldehyde, methanol) as the antibody's epitope may be sensitive to certain fixatives.[3]	
Incorrect antibody dilution.	Optimize the primary antibody concentration by performing a titration.[25]	
Fading of fluorescent signal.	Use an anti-fade mounting medium and store slides in the dark at 4°C.[1][25] Image samples promptly after staining.	
High Background	Insufficient blocking.	Increase the blocking time and/or use serum from the same species as the secondary antibody.[12][25]
Non-specific secondary antibody binding.	Use a secondary antibody that has been pre-adsorbed against the species of your sample. Include a control with only the secondary antibody. [25]	



---

Autofluorescence.	Use unstained cells as a control to check for autofluorescence. If problematic, try a different fixative or use a quenching step.[12][25]	
Non-specific Staining	Primary antibody cross-reactivity.	Use a well-characterized and specific primary antibody. Validate with a negative control (e.g., MAP17 knockdown cells).[25]
Cell damage during permeabilization.	Use a milder permeabilization agent or reduce the incubation time.[1]	
Artifacts.	Ensure cells are healthy and not overgrown before fixation. Wash cells gently to avoid detachment.[26]	

---

## Experimental Protocols

### Western Blot Protocol for MAP17

- Cell Lysis:
  - Wash cells with ice-cold PBS.
  - Lyse cells in RIPA buffer containing protease inhibitors.
  - Scrape cells and transfer the lysate to a microcentrifuge tube.
  - Incubate on ice for 30 minutes with occasional vortexing.
  - Centrifuge at 14,000 x g for 15 minutes at 4°C.
  - Collect the supernatant (protein extract).

- Protein Quantification:
  - Determine the protein concentration of the lysate using a BCA or Bradford protein assay.
- Sample Preparation:
  - Mix 20-30 µg of protein with Laemmli sample buffer.
  - Boil the samples at 95-100°C for 5 minutes.
- SDS-PAGE:
  - Load samples onto a polyacrylamide gel (a 12% or 15% gel is suitable for the 17 kDa **MAP17** protein).
  - Run the gel until the dye front reaches the bottom.
- Protein Transfer:
  - Transfer the separated proteins from the gel to a PVDF or nitrocellulose membrane.
- Blocking:
  - Block the membrane with 5% non-fat dry milk or 5% BSA in TBST (Tris-buffered saline with 0.1% Tween 20) for 1 hour at room temperature.[17]
- Primary Antibody Incubation:
  - Incubate the membrane with a primary antibody against **MAP17** diluted in blocking buffer overnight at 4°C with gentle agitation.[17]
- Washing:
  - Wash the membrane three times for 10 minutes each with TBST.[5]
- Secondary Antibody Incubation:
  - Incubate the membrane with an HRP-conjugated secondary antibody diluted in blocking buffer for 1 hour at room temperature.[5]

- Washing:
  - Wash the membrane three times for 10 minutes each with TBST.
- Detection:
  - Incubate the membrane with an enhanced chemiluminescence (ECL) substrate.
  - Detect the signal using an imaging system or X-ray film.

## qPCR Protocol for MAP17 mRNA Quantification

- RNA Extraction:
  - Extract total RNA from cultured cells using a commercial RNA extraction kit or the TRIzol method.
  - Treat the RNA with DNase I to remove any contaminating genomic DNA.
  - Assess RNA quality and quantity using a spectrophotometer or a Bioanalyzer.
- Reverse Transcription:
  - Synthesize cDNA from 1 µg of total RNA using a reverse transcription kit with oligo(dT) or random hexamer primers.[\[2\]](#)
- qPCR Reaction Setup:
  - Prepare a master mix containing SYBR Green qPCR master mix, forward and reverse primers for **MAP17**, and nuclease-free water.
  - Aliquot the master mix into qPCR plates or tubes.
  - Add diluted cDNA to each well.
  - Include a no-template control (NTC) and a no-reverse-transcriptase control (-RT).
- qPCR Cycling:

- Perform the qPCR reaction in a real-time PCR instrument with a standard cycling protocol (e.g., initial denaturation at 95°C, followed by 40 cycles of denaturation at 95°C and annealing/extension at 60°C).[2]
- Data Analysis:
  - Determine the C<sub>q</sub> (quantification cycle) values for each sample.
  - Analyze the melt curve to ensure the amplification of a single specific product.
  - Calculate the relative expression of **MAP17** mRNA using the  $\Delta\Delta C_q$  method, normalizing to a stable housekeeping gene (e.g., GAPDH, ACTB).

## Immunofluorescence Protocol for MAP17

- Cell Seeding:
  - Seed cells on sterile glass coverslips in a culture plate and allow them to adhere and grow overnight.[14]
- Fixation:
  - Wash the cells briefly with PBS.
  - Fix the cells with 4% paraformaldehyde in PBS for 15 minutes at room temperature.[14]
- Washing:
  - Wash the cells three times for 5 minutes each with PBS.[1]
- Permeabilization:
  - Permeabilize the cells with 0.1-0.25% Triton X-100 in PBS for 10 minutes.[1][14]
- Blocking:
  - Block non-specific binding by incubating the cells with a blocking buffer (e.g., 1-3% BSA in PBS) for 30-60 minutes at room temperature.[1]

- Primary Antibody Incubation:
  - Incubate the cells with a primary antibody against **MAP17** diluted in blocking buffer for 1-2 hours at room temperature or overnight at 4°C in a humidified chamber.[3]
- Washing:
  - Wash the cells three times for 5 minutes each with PBS.[1]
- Secondary Antibody Incubation:
  - Incubate the cells with a fluorescently labeled secondary antibody diluted in blocking buffer for 1 hour at room temperature, protected from light.[1]
- Washing:
  - Wash the cells three times for 5 minutes each with PBS, protected from light.[1]
- Counterstaining (Optional):
  - Incubate the cells with a nuclear counterstain like DAPI for 5 minutes.
  - Wash briefly with PBS.
- Mounting:
  - Mount the coverslips onto microscope slides using an anti-fade mounting medium.[1]
- Imaging:
  - Visualize the staining using a fluorescence microscope.

## Signaling Pathways and Experimental Workflows

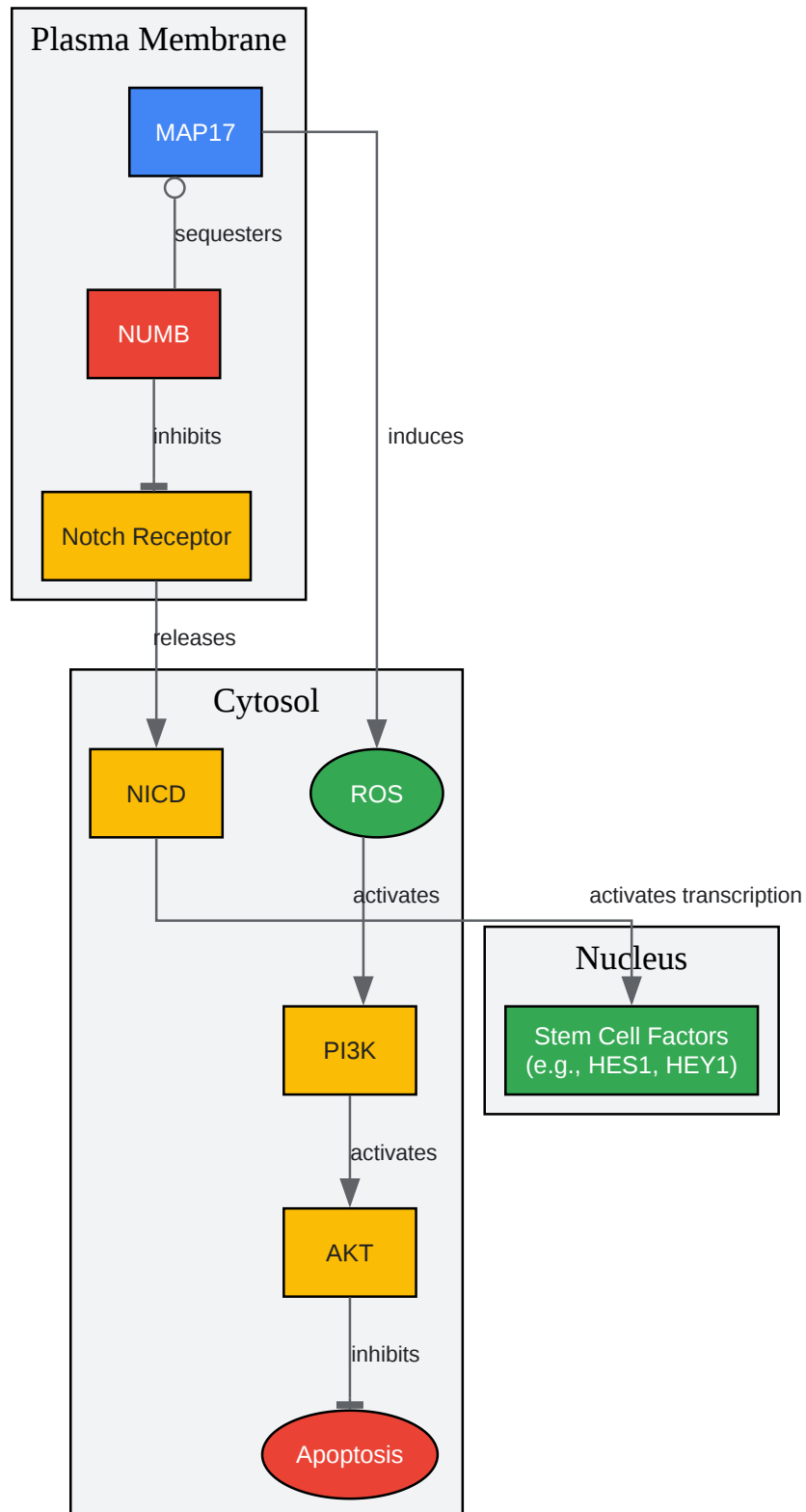

[Click to download full resolution via product page](#)

Caption: **MAP17** signaling pathways leading to apoptosis inhibition and stem cell factor activation.

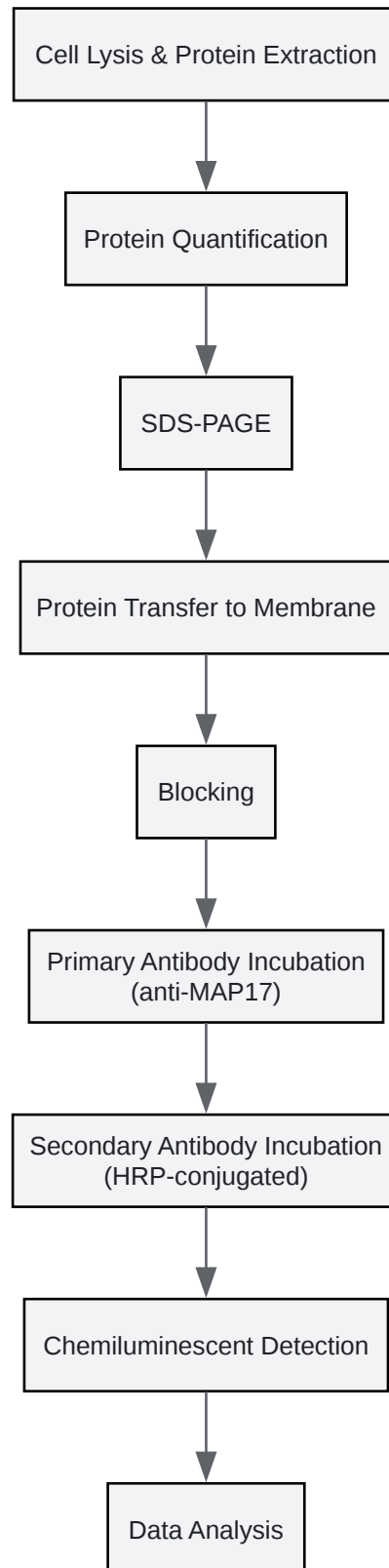

[Click to download full resolution via product page](#)

Caption: Experimental workflow for Western blotting of **MAP17**.

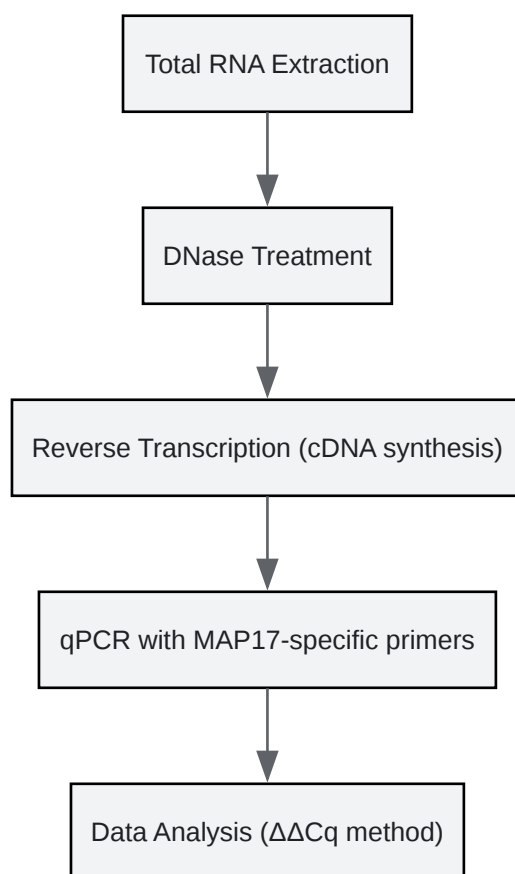

[Click to download full resolution via product page](#)

Caption: Experimental workflow for quantifying **MAP17** mRNA by qPCR.

### *Need Custom Synthesis?*

*BenchChem offers custom synthesis for rare earth carbides and specific isotopic labeling.*

*Email: [info@benchchem.com](mailto:info@benchchem.com) or [Request Quote Online](#).*

## References

- 1. arigobio.com [arigobio.com]
- 2. stackscientific.nd.edu [stackscientific.nd.edu]



- 3. [biotium.com](https://biotium.com) [biotium.com]
- 4. The cargo protein MAP17 (PDZK1IP1) regulates the immune microenvironment - PMC [pmc.ncbi.nlm.nih.gov]
- 5. [bosterbio.com](https://bosterbio.com) [bosterbio.com]
- 6. MAP17 overexpression is a common characteristic of carcinomas - PubMed [pubmed.ncbi.nlm.nih.gov]
- 7. [oldresearch.unityhealth.to](https://oldresearch.unityhealth.to) [oldresearch.unityhealth.to]
- 8. Quantification of mRNA using real-time RT-PCR - PubMed [pubmed.ncbi.nlm.nih.gov]
- 9. Western Blot Troubleshooting Guide - TotalLab [totallab.com]
- 10. [researchgate.net](https://researchgate.net) [researchgate.net]
- 11. Western Blotting Troubleshooting Guide | Cell Signaling Technology [cellsignal.com]
- 12. [ibidi.com](https://ibidi.com) [ibidi.com]
- 13. [bio-rad.com](https://bio-rad.com) [bio-rad.com]
- 14. [documents.thermofisher.com](https://documents.thermofisher.com) [documents.thermofisher.com]
- 15. [nacalai.com](https://nacalai.com) [nacalai.com]
- 16. [ulab360.com](https://ulab360.com) [ulab360.com]
- 17. [sinobiological.com](https://sinobiological.com) [sinobiological.com]
- 18. [researchgate.net](https://researchgate.net) [researchgate.net]
- 19. Large scale genetic screen identifies MAP17 as protein bypassing TNF-induced growth arrest - PubMed [pubmed.ncbi.nlm.nih.gov]
- 20. Western blot troubleshooting guide! [jacksonimmuno.com]
- 21. [bosterbio.com](https://bosterbio.com) [bosterbio.com]
- 22. Western Blot Troubleshooting | Thermo Fisher Scientific - US [thermofisher.com]
- 23. [pcrbio.com](https://pcrbio.com) [pcrbio.com]
- 24. [bu.edu](https://bu.edu) [bu.edu]
- 25. Immunofluorescence (IF) Troubleshooting Guide | Cell Signaling Technology [cellsignal.com]
- 26. [ptglab.com](https://ptglab.com) [ptglab.com]
- To cite this document: BenchChem. [Variability in MAP17 expression in different cell passages]. BenchChem, [2025]. [Online PDF]. Available at:

[<https://www.benchchem.com/product/b15597279#variability-in-map17-expression-in-different-cell-passages>]

---

### Disclaimer & Data Validity:

The information provided in this document is for Research Use Only (RUO) and is strictly not intended for diagnostic or therapeutic procedures. While BenchChem strives to provide accurate protocols, we make no warranties, express or implied, regarding the fitness of this product for every specific experimental setup.

**Technical Support:** The protocols provided are for reference purposes. Unsure if this reagent suits your experiment? [[Contact our Ph.D. Support Team for a compatibility check](#)]

**Need Industrial/Bulk Grade?** [Request Custom Synthesis Quote](#)

## BenchChem

Our mission is to be the trusted global source of essential and advanced chemicals, empowering scientists and researchers to drive progress in science and industry.

### Contact

Address: 3281 E Guasti Rd  
Ontario, CA 91761, United States  
Phone: (601) 213-4426  
Email: [info@benchchem.com](mailto:info@benchchem.com)