

Validating the Therapeutic Targets of Sipoglitazar: A Comparative Guide for Researchers

Author: BenchChem Technical Support Team. **Date:** December 2025

Compound of Interest

Compound Name: *Sipoglitazar*

Cat. No.: *B1680977*

[Get Quote](#)

For researchers, scientists, and drug development professionals, this guide provides a comprehensive comparison of **Sipoglitazar** and other peroxisome proliferator-activated receptor (PPAR) agonists. This document summarizes key experimental data, details methodologies for crucial experiments, and visualizes complex biological pathways and workflows to support the validation of these therapeutic targets.

Sipoglitazar is a novel anti-diabetic agent that acts as a triple agonist, targeting human peroxisome proliferator-activated receptors (hPPARs) gamma (γ), alpha (α), and delta (δ)^[1]. These nuclear receptors are critical regulators of glucose and lipid metabolism, making them attractive targets for therapeutic intervention in metabolic diseases. To objectively evaluate the therapeutic potential of **Sipoglitazar**, this guide provides a comparative analysis with other prominent PPAR agonists: Saroglitazar, Aloglitazar, and Tesaglitazar.

Comparative Analysis of PPAR Agonist Potency

The in vitro potency of PPAR agonists is a key indicator of their therapeutic potential. This is typically determined through transactivation assays that measure the concentration of the drug required to achieve 50% of its maximal activity (EC50). While specific EC50 values for **Sipoglitazar** across all three PPAR isoforms are not publicly available, data for comparator compounds highlight their distinct profiles.

Compound	PPAR α EC50 (nM)	PPAR γ EC50 (nM)	PPAR δ EC50 (nM)
Sipoglitazar	Data not available	Data not available	Data not available
Saroglitazar	0.00065	3	Data not available
Aleglitazar	5	9	Data not available
Tesaglitazar	3600 (human)	200 (rat/human)	Data not available

Note: The EC50 values are sourced from various preclinical studies and may vary depending on the specific assay conditions.

Clinical Efficacy in Treating Diabetic Dyslipidemia

Clinical trials provide essential data on the efficacy and safety of these compounds in a real-world setting. The following table summarizes key findings from clinical trials of Saroglitazar, Aleglitazar, and Tesaglitazar in patients with type 2 diabetes and dyslipidemia. Clinical trial data for **Sipoglitazar** (also known as TAK-559) is limited in the public domain.

Compound	Key Efficacy Outcomes	Reference
Sipoglitazar (TAK-559)	A study was conducted to determine the safety and efficacy of TAK-559 combined with glyburide in treating Type 2 Diabetes. However, specific quantitative results on lipid and glycemic control are not readily available in the public domain.	[2]
Saroglitazar	In a 52-week study, Saroglitazar demonstrated a significant reduction in triglycerides (66.9%), LDL-C (38.47%), total cholesterol (44.84%), and non-HDL-C (52.62%). It also showed a 0.8% absolute reduction in HbA1c.[3] In other studies, 4 mg of Saroglitazar significantly reduced triglycerides by 45.0% to 46.7%.[4]	
Aleglitazar	In a phase II trial, Aleglitazar reduced HbA1c by up to 0.85% and fasting plasma glucose by 2.16 mmol/L. It also increased HDL-C by up to 28% and reduced triglycerides by as much as 38%. However, a large phase III trial (AleCardio) was terminated due to a lack of cardiovascular efficacy and safety concerns, including an increased risk of heart failure and renal dysfunction.	

Tesaglitazar	In a 12-week dose-ranging trial, Tesaglitazar at doses of 0.5 mg to 3.0 mg produced significant reductions in fasting plasma glucose (-30.3 to -60.9 mg/dL) and triglycerides (-17.2% to -41.0%).
--------------	---

Experimental Protocols

Validating the therapeutic targets of PPAR agonists involves a series of well-defined in vitro and in vivo experiments. Below are detailed methodologies for key assays.

In Vitro Target Validation

1. Time-Resolved Fluorescence Resonance Energy Transfer (TR-FRET) Competitive Binding Assay

This assay is used to determine the binding affinity of a compound to a specific PPAR isoform.

- Principle: The assay measures the displacement of a fluorescently labeled ligand (tracer) from the ligand-binding domain (LBD) of a PPAR by a test compound. The PPAR-LBD is typically tagged (e.g., with GST), and a terbium-labeled antibody against the tag is used. When the tracer is bound to the PPAR-LBD, excitation of the terbium-labeled antibody results in fluorescence resonance energy transfer to the tracer, producing a high TR-FRET signal. A test compound that binds to the PPAR-LBD will displace the tracer, leading to a decrease in the TR-FRET signal.
- Protocol Outline:
 - Reagent Preparation: Prepare a complete TR-FRET assay buffer containing DTT. Dilute the test compound, a known competitor (positive control), and a solvent control to a 2X concentration in the assay buffer. Prepare a 4X solution of the fluorescent tracer (e.g., Fluormone™ Pan-PPAR Green). Prepare a 4X solution of the PPAR-LBD and the terbium-labeled anti-tag antibody.

- Assay Plate Setup: Add the 2X test compound or control solutions to the wells of a microplate.
- Addition of Assay Components: Add the 4X fluorescent tracer solution to the wells. Subsequently, add the 4X PPAR-LBD/terbium-antibody mixture.
- Incubation: Cover the plate to protect it from light and incubate at room temperature for a specified period (e.g., 2-6 hours) to allow the binding reaction to reach equilibrium.
- Data Acquisition: Measure the fluorescent emission at two wavelengths (e.g., 495 nm for terbium and 520 nm for the tracer) using a microplate reader.
- Data Analysis: Calculate the TR-FRET ratio (emission at 520 nm / emission at 495 nm). Plot the TR-FRET ratio against the log of the test compound concentration to generate a competition curve and determine the IC50 value.

2. PPAR Luciferase Reporter Gene Transactivation Assay

This cell-based assay measures the functional activity of a compound as a PPAR agonist.

- Principle: Cells are co-transfected with two plasmids: an expression vector for the target human PPAR isoform and a reporter vector containing a luciferase gene under the control of a PPAR response element (PPRE). If the test compound activates the PPAR, the PPAR/RXR α heterodimer binds to the PPRE and drives the expression of the luciferase enzyme. The amount of light produced upon addition of a luciferase substrate is proportional to the level of PPAR activation.
- Protocol Outline:
 - Cell Culture and Transfection: Seed cells (e.g., HepG2) in a 96-well plate. Co-transfect the cells with the PPAR expression plasmid and the PPRE-luciferase reporter plasmid using a suitable transfection reagent.
 - Compound Treatment: After an incubation period to allow for gene expression, treat the cells with various concentrations of the test compound or a reference agonist.

- Incubation: Incubate the cells for a sufficient period (e.g., 24 hours) to allow for PPAR activation and luciferase expression.
- Cell Lysis and Luciferase Assay: Lyse the cells and add a luciferase assay reagent containing the substrate (e.g., D-luciferin).
- Data Acquisition: Measure the luminescence using a luminometer.
- Data Analysis: Plot the luminescence signal against the log of the test compound concentration to generate a dose-response curve and determine the EC50 value.

In Vivo Target Validation

Animal Models for Diabetes and Dyslipidemia

- db/db Mice: These mice have a mutation in the leptin receptor gene, leading to obesity, insulin resistance, and hyperglycemia, making them a suitable model for type 2 diabetes.
- Zucker Diabetic Fatty (ZDF) Rats: These rats also exhibit obesity, insulin resistance, and develop hyperglycemia, closely mimicking the pathophysiology of type 2 diabetes in humans.
- High-Fat Diet-Induced Obese and Insulin-Resistant Rodents: Feeding rodents a high-fat diet induces obesity, dyslipidemia, and insulin resistance, providing a relevant model to test the efficacy of PPAR agonists.
- Streptozotocin (STZ)-Induced Diabetic Rodents: STZ is a chemical that is toxic to pancreatic β -cells, and its administration induces a state of insulin-deficient diabetes, modeling type 1 diabetes.

Visualizing the Pathways and Processes

To further clarify the mechanisms and methodologies discussed, the following diagrams have been generated using the Graphviz DOT language.

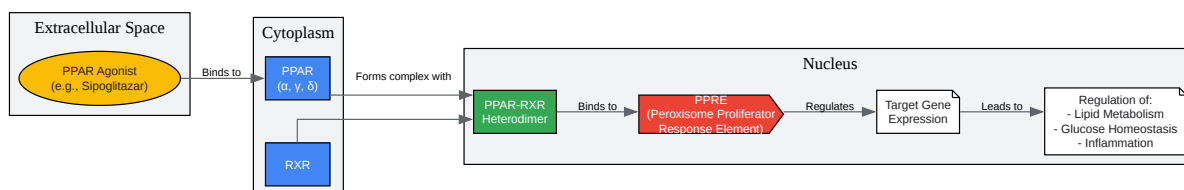

[Click to download full resolution via product page](#)

Caption: PPAR Signaling Pathway

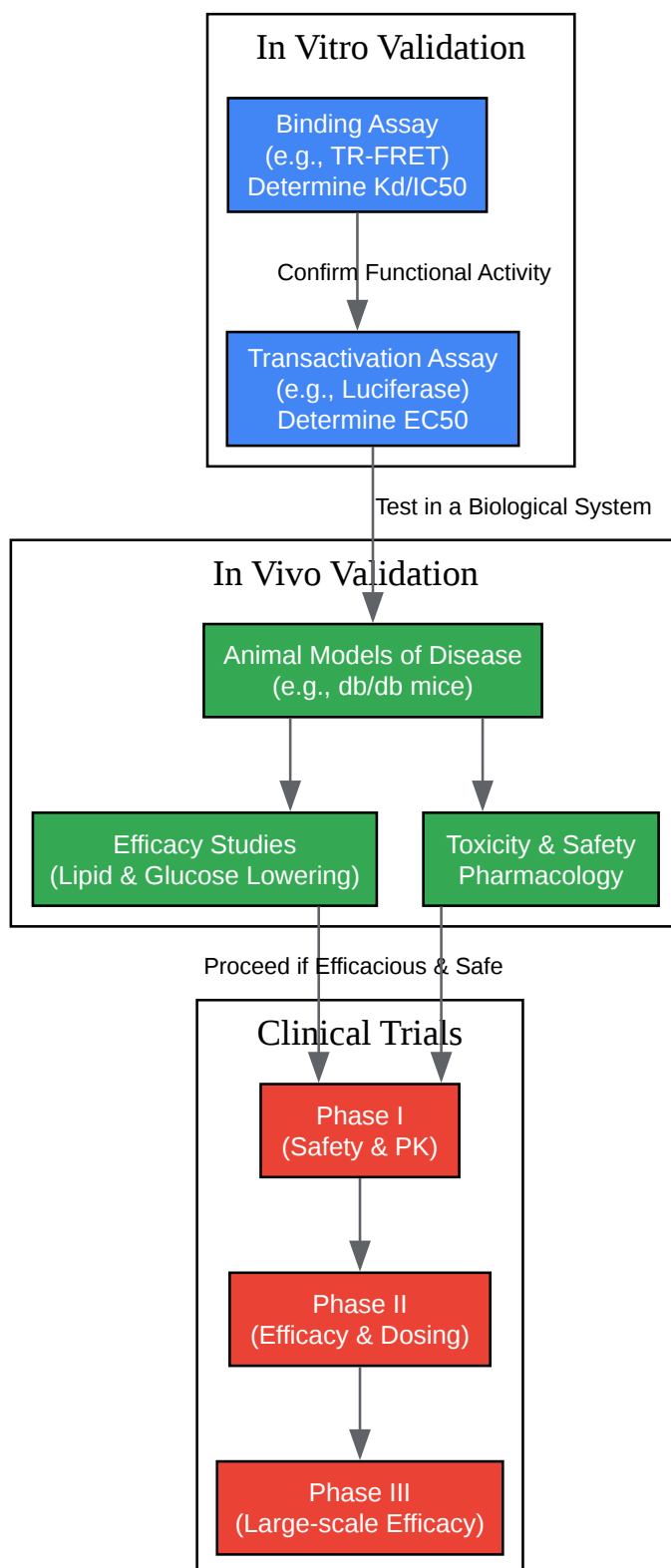

[Click to download full resolution via product page](#)

Caption: Target Validation Workflow

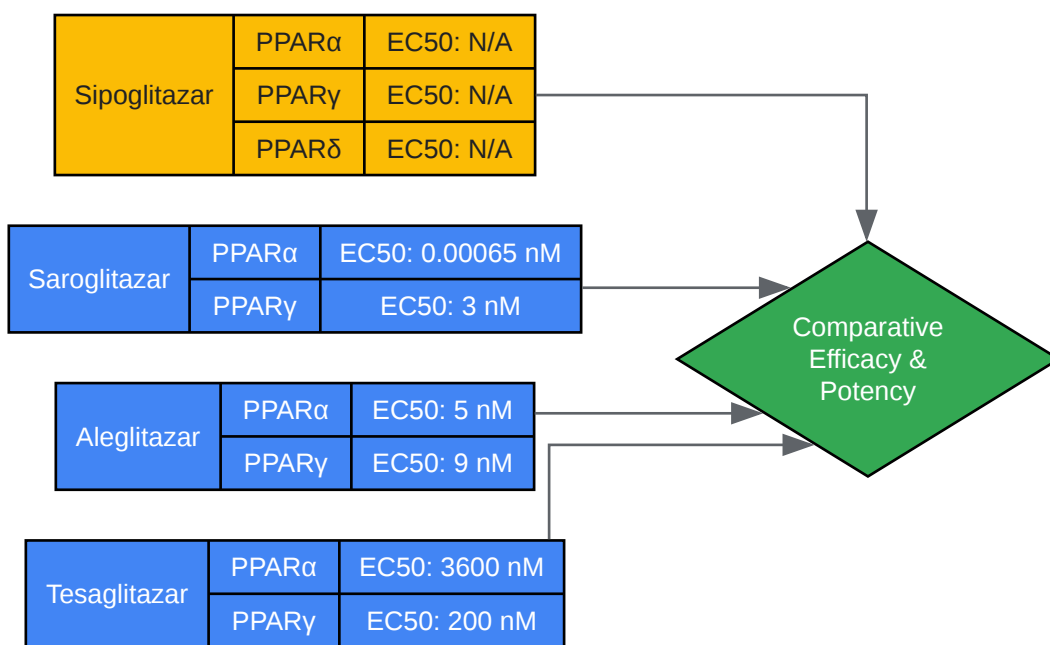

[Click to download full resolution via product page](#)

Caption: PPAR Agonist Comparison

Need Custom Synthesis?

BenchChem offers custom synthesis for rare earth carbides and specific isotopic labeling.

Email: info@benchchem.com or [Request Quote Online](#).

References

- 1. Metabolic fate of sipoglitazar, a novel oral PPAR agonist with activities for PPAR- γ , - α and - δ , in rats and monkeys and comparison with humans in vitro - PubMed [pubmed.ncbi.nlm.nih.gov]
- 2. meddatax.com [meddatax.com]
- 3. diabetesjournals.org [diabetesjournals.org]
- 4. sdiopr.s3.ap-south-1.amazonaws.com [sdiopr.s3.ap-south-1.amazonaws.com]
- To cite this document: BenchChem. [Validating the Therapeutic Targets of Sipoglitazar: A Comparative Guide for Researchers]. BenchChem, [2025]. [Online PDF]. Available at: [https://www.benchchem.com/product/b1680977#validating-the-therapeutic-targets-of-sipoglitazar]

Disclaimer & Data Validity:

The information provided in this document is for Research Use Only (RUO) and is strictly not intended for diagnostic or therapeutic procedures. While BenchChem strives to provide accurate protocols, we make no warranties, express or implied, regarding the fitness of this product for every specific experimental setup.

Technical Support: The protocols provided are for reference purposes. Unsure if this reagent suits your experiment? [[Contact our Ph.D. Support Team for a compatibility check](#)]

Need Industrial/Bulk Grade? [Request Custom Synthesis Quote](#)

BenchChem

Our mission is to be the trusted global source of essential and advanced chemicals, empowering scientists and researchers to drive progress in science and industry.

Contact

Address: 3281 E Guasti Rd

Ontario, CA 91761, United States

Phone: (601) 213-4426

Email: info@benchchem.com