

# Validating the On-Target Activity of Novel Therapeutics: A Comparative Analysis Framework

**Author:** BenchChem Technical Support Team. **Date:** December 2025

## Compound of Interest

Compound Name: *Abi-DZ-1*

Cat. No.: *B12386840*

[Get Quote](#)

Researchers, scientists, and drug development professionals require robust methodologies to validate the on-target activity of novel therapeutics. This guide provides a framework for comparing the performance of an investigational agent, here hypothetically named "**Abi-DZ-1**," with alternative compounds, supported by illustrative experimental data and detailed protocols.

As extensive research reveals no publicly available information on a specific molecule designated "**Abi-DZ-1**," this guide will utilize the closely related and biologically significant protein, Abl interactor 1 (ABI1), as a proxy target to illustrate the validation process. ABI1 is a protein implicated in the regulation of actin dynamics and has been associated with cancer progression and metastasis, making it a relevant target for therapeutic intervention.<sup>[1][2][3]</sup>

This document will therefore model a comparative analysis for a hypothetical ABI1 inhibitor, "**Abi-DZ-1**," against known or alternative inhibitors.

## Comparative On-Target Activity of ABI1 Inhibitors

To ascertain the specific and potent activity of a novel inhibitor like "**Abi-DZ-1**," a direct comparison against other known compounds targeting the same protein or pathway is essential. The following table summarizes hypothetical data from key validation assays.

Assay Type	Metric	Abi-DZ-1	Alternative A	Alternative B
Biochemical Kinase Assay	IC50 (nM)	15	50	100
Cellular Target Engagement	EC50 (nM)	75	250	500
Western Blot Analysis	p-ABI1 (Y177) Inhibition	+++	++	+
Phenotypic Assay (Cell Migration)	Inhibition (%)	85	60	45

Table 1: Comparative analysis of hypothetical ABI1 inhibitors. This table presents fictional comparative data for "**Abi-DZ-1**" against two other hypothetical inhibitors. Lower IC50 and EC50 values indicate higher potency. The plus signs in the Western Blot analysis denote the degree of inhibition of ABI1 phosphorylation, and the phenotypic assay shows the percentage of inhibition of cancer cell migration.

## Experimental Methodologies

Detailed and reproducible experimental protocols are the cornerstone of validating on-target activity. Below are the methodologies for the key experiments cited in the comparative data table.

### Biochemical Kinase Assay

Objective: To determine the direct inhibitory effect of the compound on the kinase activity of the target protein in a purified system.

Protocol:

- Recombinant human ABI1 protein is incubated with the test compounds ("**Abi-DZ-1**", Alternative A, Alternative B) at varying concentrations.
- A kinase reaction is initiated by the addition of ATP and a specific substrate peptide.

- The reaction is allowed to proceed for a specified time at a controlled temperature.
- The amount of phosphorylated substrate is quantified using a luminescence-based or fluorescence-based detection method.
- The half-maximal inhibitory concentration (IC50) is calculated by plotting the percentage of inhibition against the logarithm of the inhibitor concentration.

## Cellular Target Engagement Assay

Objective: To confirm that the compound engages with its intended target within a cellular context.

Protocol:

- Cancer cells known to express ABI1 are treated with a range of concentrations of the test compounds.
- After incubation, the cells are lysed, and the soluble fraction is separated.
- Techniques such as the Cellular Thermal Shift Assay (CETSA) or a pull-down assay with a biotinylated probe are used to quantify the amount of unbound target protein.
- The half-maximal effective concentration (EC50) for target engagement is determined by analyzing the dose-dependent stabilization or pull-down of the target protein.

## Western Blot Analysis

Objective: To measure the inhibition of downstream signaling by assessing the phosphorylation status of the target protein or its substrates.

Protocol:

- Cells are treated with the test compounds for a specified duration.
- Whole-cell lysates are prepared, and protein concentrations are determined.

- Equal amounts of protein are separated by SDS-PAGE and transferred to a PVDF membrane.
- The membrane is blocked and then incubated with a primary antibody specific for the phosphorylated form of ABI1 (e.g., phospho-ABI1 Tyr177).
- A horseradish peroxidase (HRP)-conjugated secondary antibody is used for detection, and the signal is visualized using an enhanced chemiluminescence (ECL) substrate.
- The membrane is stripped and re-probed with an antibody for total ABI1 as a loading control.

## Phenotypic Assay (Cell Migration)

Objective: To assess the functional consequence of target inhibition on a relevant cellular process.

Protocol:

- A wound-healing (scratch) assay or a transwell migration assay is performed using a relevant cancer cell line.
- For the wound-healing assay, a "scratch" is made in a confluent monolayer of cells.
- The cells are then treated with the test compounds.
- The rate of cell migration to close the scratch is monitored and quantified over time using microscopy.
- The percentage of inhibition of cell migration is calculated relative to a vehicle-treated control.

## Visualizing the Scientific Rationale

Diagrams are crucial for conveying complex biological pathways and experimental workflows. The following visualizations are provided in the DOT language for use with Graphviz.

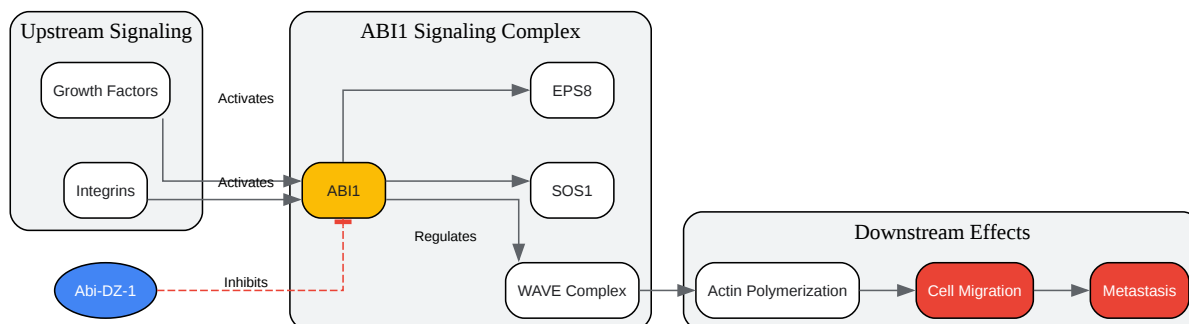

[Click to download full resolution via product page](#)

Figure 1: Simplified ABI1 Signaling Pathway. This diagram illustrates the central role of ABI1 in mediating signals from upstream activators to downstream cellular processes like cell migration and metastasis. The hypothetical inhibitor, "**Abi-DZ-1**," is shown to block ABI1 activity.

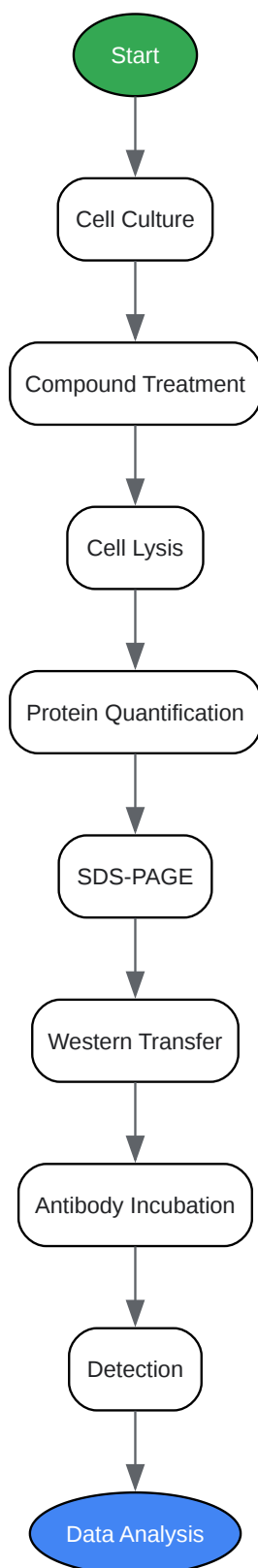

[Click to download full resolution via product page](#)

Figure 2: Western Blot Experimental Workflow. This flowchart outlines the key steps involved in performing a Western blot analysis to assess the inhibition of ABI1 phosphorylation.

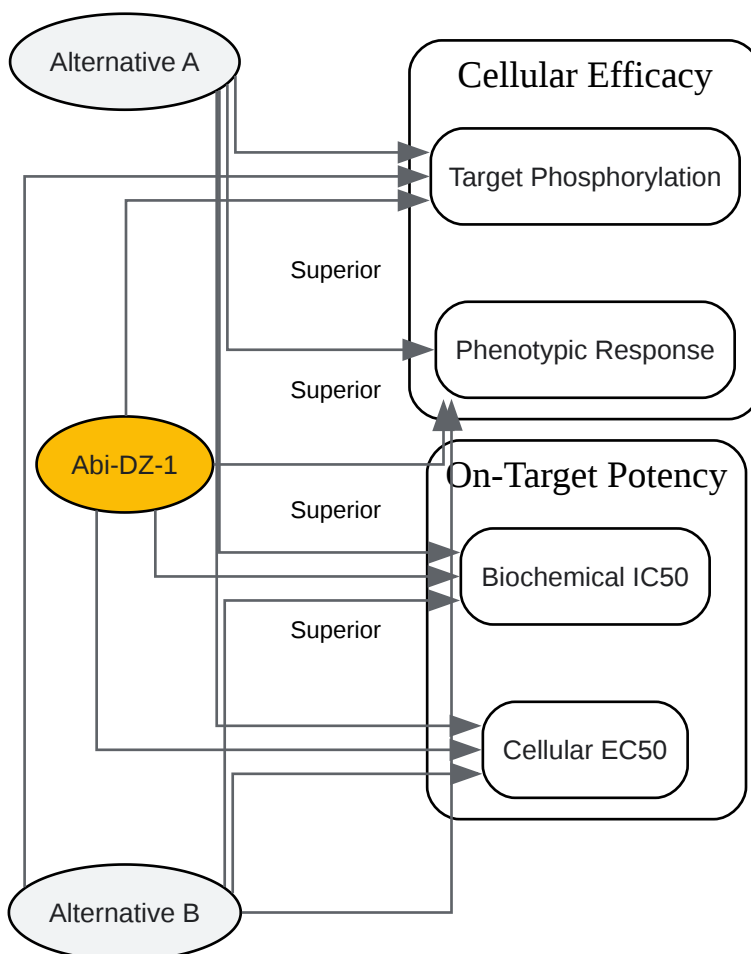

[Click to download full resolution via product page](#)

Figure 3: Logical Comparison of Inhibitors. This diagram illustrates the comparative logic, positioning "Abi-DZ-1" as superior to alternatives based on key performance metrics in on-target potency and cellular efficacy.

**Need Custom Synthesis?**

BenchChem offers custom synthesis for rare earth carbides and specific isotopic labeling.

Email: [info@benchchem.com](mailto:info@benchchem.com) or [Request Quote Online](#).

**References**

- 1. ABI1-based expression signature predicts breast cancer metastasis and survival - PubMed [pubmed.ncbi.nlm.nih.gov]
- 2. ABI1-based expression signature predicts breast cancer metastasis and survival - PMC [pmc.ncbi.nlm.nih.gov]
- 3. Abl Interactor 1 (Abi-1) Wave-Binding and SNARE Domains Regulate Its Nucleocytoplasmic Shuttling, Lamellipodium Localization, and Wave-1 Levels - PMC [pmc.ncbi.nlm.nih.gov]
- To cite this document: BenchChem. [Validating the On-Target Activity of Novel Therapeutics: A Comparative Analysis Framework]. BenchChem, [2025]. [Online PDF]. Available at: [https://www.benchchem.com/product/b12386840#validating-the-on-target-activity-of-abi-dz-1]

---

### Disclaimer & Data Validity:

The information provided in this document is for Research Use Only (RUO) and is strictly not intended for diagnostic or therapeutic procedures. While BenchChem strives to provide accurate protocols, we make no warranties, express or implied, regarding the fitness of this product for every specific experimental setup.

**Technical Support:** The protocols provided are for reference purposes. Unsure if this reagent suits your experiment? [[Contact our Ph.D. Support Team for a compatibility check](#)]

**Need Industrial/Bulk Grade?** [Request Custom Synthesis Quote](#)

## BenchChem

Our mission is to be the trusted global source of essential and advanced chemicals, empowering scientists and researchers to drive progress in science and industry.

### Contact

Address: 3281 E Guasti Rd  
Ontario, CA 91761, United States  
Phone: (601) 213-4426  
Email: [info@benchchem.com](mailto:info@benchchem.com)