

Validating the MAP17-NUMB Interaction In Vivo: A Comparative Guide

Author: BenchChem Technical Support Team. **Date:** December 2025

Compound of Interest

Compound Name: MAP17

Cat. No.: B15597279

[Get Quote](#)

For researchers, scientists, and drug development professionals, establishing the validity of protein-protein interactions within a living organism is a critical step in understanding disease pathways and developing targeted therapies. This guide provides a comparative overview of experimental approaches to validate the interaction between the Membrane-Associated Protein 17 (**MAP17**) and the cell fate determinant protein NUMB in vivo.

The interaction between **MAP17** and NUMB has been identified as a key event in the activation of the Notch signaling pathway, which is implicated in cancer stem cell regulation.^{[1][2][3]} Overexpression of **MAP17** leads to the sequestration of NUMB, preventing its inhibitory action on Notch and thereby promoting tumorigenicity.^{[1][2][3]} Validating this interaction in a physiological context is crucial for the development of therapeutics targeting this pathway.

This guide will compare two primary methods for which experimental evidence exists for the **MAP17**-NUMB interaction—Co-Immunoprecipitation (Co-IP) and Proximity Ligation Assay (PLA)—and discuss potential alternative methods. We will provide detailed experimental protocols, quantitative data from existing studies, and visualizations to aid in experimental design and interpretation.

Quantitative Data Presentation

While direct quantitative data for the **MAP17**-NUMB interaction in vivo is not extensively published, data from in vitro studies using human cell lines provides a strong foundation for what to expect in an in vivo setting, such as in patient-derived xenograft (PDX) models where **MAP17** levels correlate with tumorsphere formation capability.^{[1][3]} The following table

summarizes the quantitative findings from Proximity Ligation Assays performed in HeLa and T47D cell lines, which can be extrapolated to inform in vivo experimental design.

Cell Line	Condition	Mean PLA Events per Cell (\pm SEM)	Fold Change vs. Empty Vector	Statistical Significance (p-value)	Reference
HeLa	Empty Vector	5.2 \pm 1.1	-	-	[1][2]
HeLa	MAP17 Overexpression	28.5 \pm 3.4	~5.5	p < 0.01	[1][2]
HeLa	Truncated MAP17	6.1 \pm 1.5	~1.2	Not Significant	[1][2]
T47D	Empty Vector	4.8 \pm 0.9	-	-	[1][2]
T47D	MAP17 Overexpression	25.1 \pm 2.9	~5.2	p < 0.01	[1][2]
T47D	Truncated MAP17	5.5 \pm 1.2	~1.1	Not Significant	[1][2]

Signaling Pathway and Experimental Workflows

To visualize the molecular and experimental context, the following diagrams illustrate the **MAP17-NUMB** signaling pathway and the workflows for Co-Immunoprecipitation and Proximity Ligation Assay.

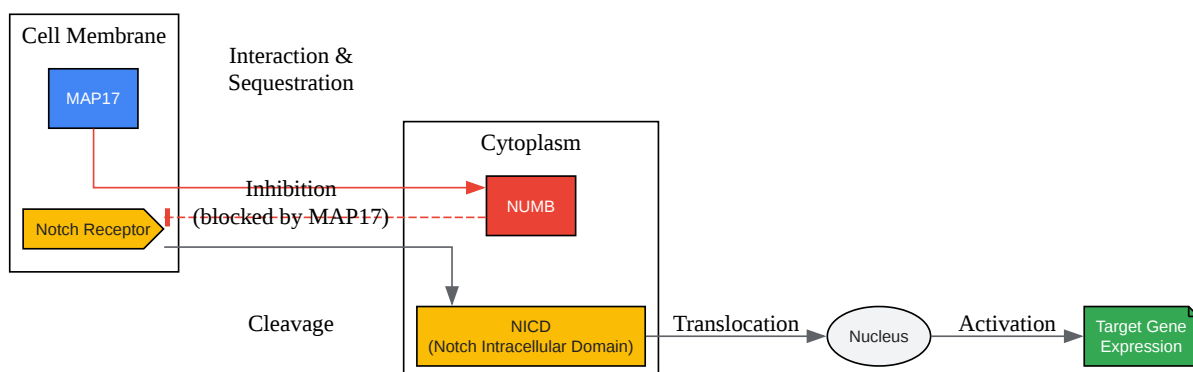

[Click to download full resolution via product page](#)

MAP17-NUMB Signaling Pathway

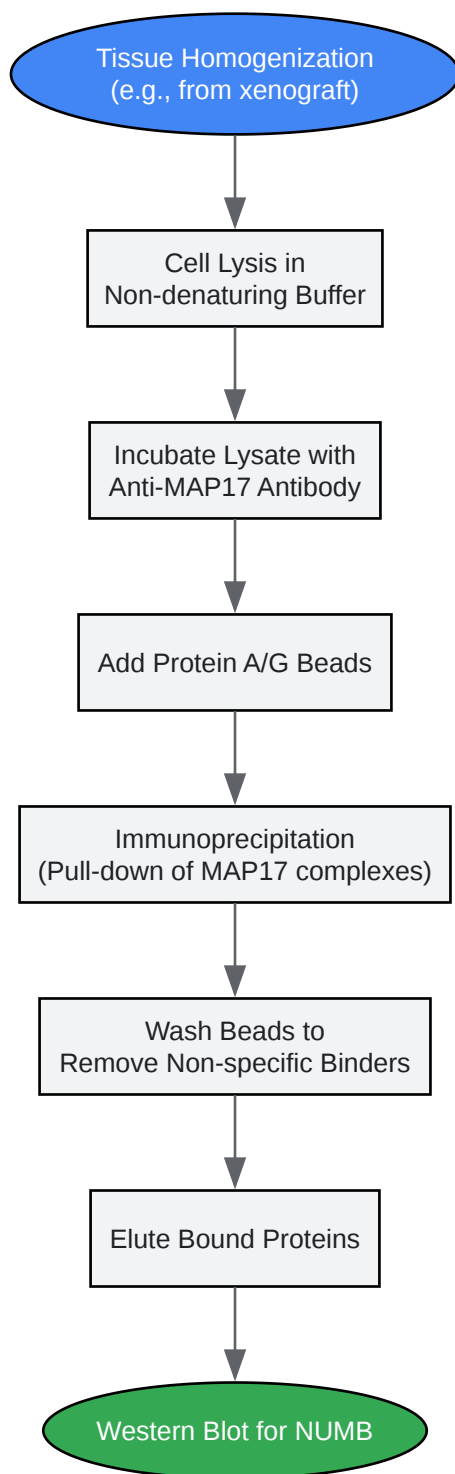

[Click to download full resolution via product page](#)

Co-Immunoprecipitation Workflow

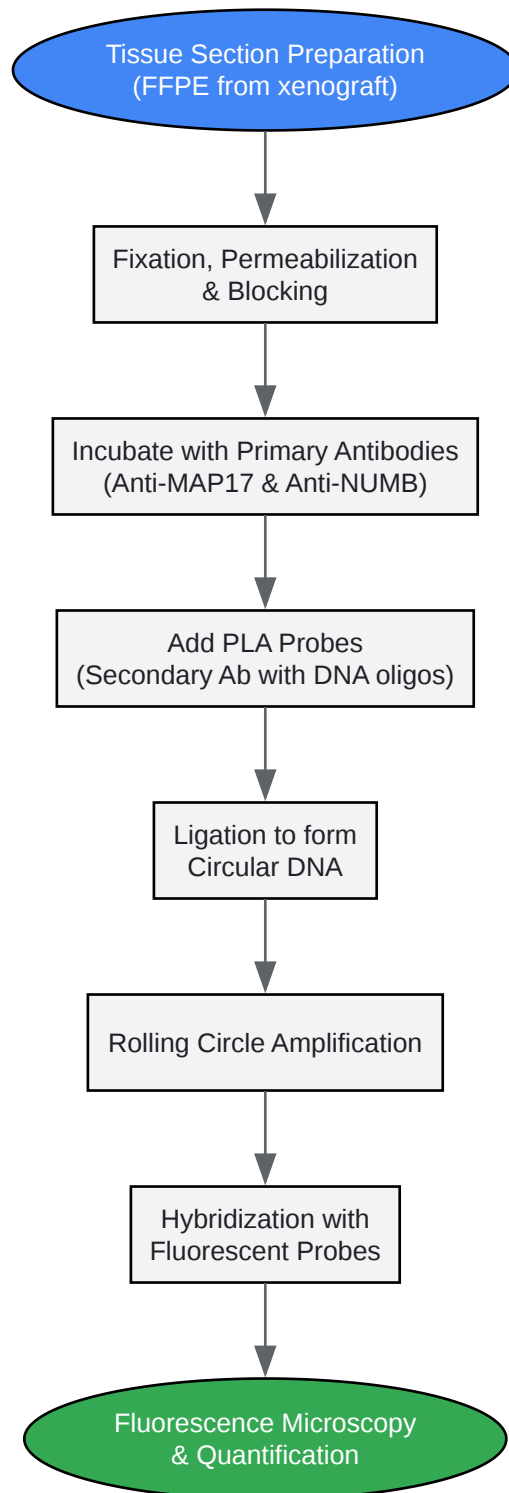

Co-Immunoprecipitation
(Qualitative/Semi-Quantitative)

Proximity Ligation Assay
(Quantitative & Spatial)

Förster Resonance Energy Transfer
(Live cells, high spatial resolution)

Tandem Affinity Purification-MS
(High-throughput, identifies complexes)

[Click to download full resolution via product page](#)

Need Custom Synthesis?

BenchChem offers custom synthesis for rare earth carbides and specific isotopic labeling.

Email: info@benchchem.com or [Request Quote Online](#).

References

- 1. aacrjournals.org [aacrjournals.org]
- 2. researchgate.net [researchgate.net]
- 3. The Cargo Protein MAP17 (PDZK1IP1) Regulates the Cancer Stem Cell Pool Activating the Notch Pathway by Abducting NUMB - PubMed [pubmed.ncbi.nlm.nih.gov]
- To cite this document: BenchChem. [Validating the MAP17-NUMB Interaction In Vivo: A Comparative Guide]. BenchChem, [2025]. [Online PDF]. Available at: [https://www.benchchem.com/product/b15597279#validating-the-interaction-between-map17-and-numb-in-vivo]

Disclaimer & Data Validity:

The information provided in this document is for Research Use Only (RUO) and is strictly not intended for diagnostic or therapeutic procedures. While BenchChem strives to provide accurate protocols, we make no warranties, express or implied, regarding the fitness of this product for every specific experimental setup.

Technical Support: The protocols provided are for reference purposes. Unsure if this reagent suits your experiment? [[Contact our Ph.D. Support Team for a compatibility check](#)]

Need Industrial/Bulk Grade? [Request Custom Synthesis Quote](#)

BenchChem

Our mission is to be the trusted global source of essential and advanced chemicals, empowering scientists and researchers to drive progress in science and industry.

Contact

Address: 3281 E Guasti Rd

Ontario, CA 91761, United States

Phone: (601) 213-4426

Email: info@benchchem.com