

Validating the Function of a Newly Discovered F420-Dependent Enzyme: A Comparative Guide

Author: BenchChem Technical Support Team. **Date:** December 2025

Compound of Interest

Compound Name: *coenzyme F420*

Cat. No.: *B3055463*

[Get Quote](#)

For researchers, scientists, and drug development professionals, this guide provides a comprehensive framework for validating the function of a newly discovered F420-dependent enzyme. It offers an objective comparison of alternative methods, supported by experimental data, to facilitate robust characterization of these unique biocatalysts.

The deazaflavin cofactor F420 is a crucial mediator of low-potential hydride transfer reactions in various archaea and bacteria. Enzymes dependent on this cofactor are involved in diverse metabolic pathways, including methanogenesis, antibiotic biosynthesis, and the activation of prodrugs.^{[1][2]} As interest in these enzymes for biocatalysis and therapeutic applications grows, a systematic approach to validating the function of newly identified candidates is essential. This guide outlines a stepwise validation workflow, from initial expression to detailed kinetic characterization, and compares the available methodologies at each stage.

A Step-by-Step Workflow for Functional Validation

The functional validation of a newly discovered F420-dependent enzyme typically follows a multi-step process. This workflow ensures a thorough characterization of the enzyme's properties and activities.

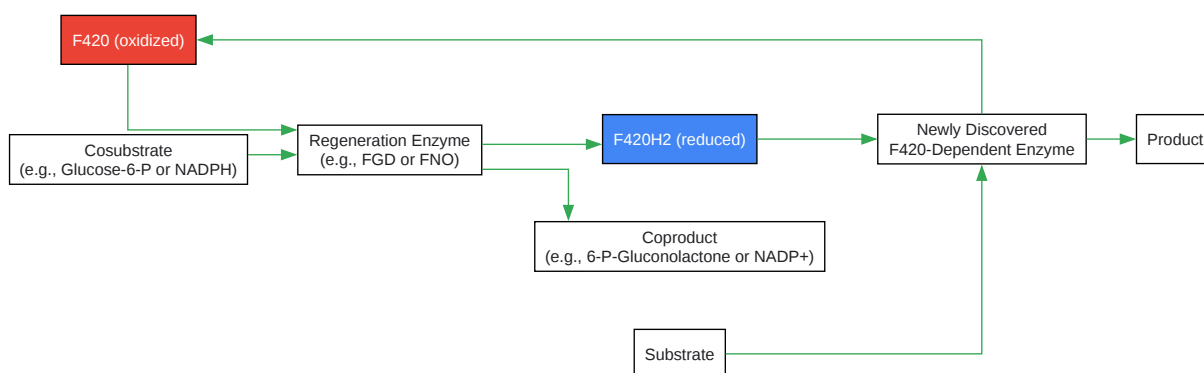
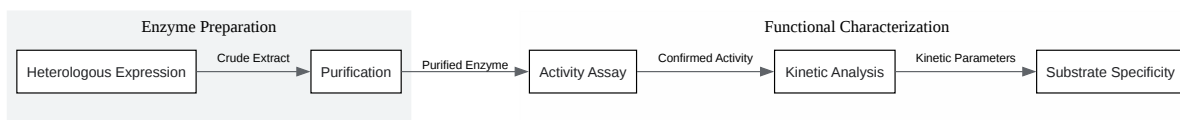

[Click to download full resolution via product page](#)

Need Custom Synthesis?

BenchChem offers custom synthesis for rare earth carbides and specific isotopic labeling.

Email: info@benchchem.com or [Request Quote Online](#).

References

- 1. Cofactor F420-Dependent Enzymes: An Under-Explored Resource for Asymmetric Redox Biocatalysis [mdpi.com]
- 2. researchgate.net [researchgate.net]

- To cite this document: BenchChem. [Validating the Function of a Newly Discovered F420-Dependent Enzyme: A Comparative Guide]. BenchChem, [2025]. [Online PDF]. Available at: [<https://www.benchchem.com/product/b3055463#how-to-validate-the-function-of-a-newly-discovered-f420-dependent-enzyme>]

Disclaimer & Data Validity:

The information provided in this document is for Research Use Only (RUO) and is strictly not intended for diagnostic or therapeutic procedures. While BenchChem strives to provide accurate protocols, we make no warranties, express or implied, regarding the fitness of this product for every specific experimental setup.

Technical Support: The protocols provided are for reference purposes. Unsure if this reagent suits your experiment? [[Contact our Ph.D. Support Team for a compatibility check](#)]

Need Industrial/Bulk Grade? [Request Custom Synthesis Quote](#)

BenchChem

Our mission is to be the trusted global source of essential and advanced chemicals, empowering scientists and researchers to drive progress in science and industry.

Contact

Address: 3281 E Guasti Rd
Ontario, CA 91761, United States
Phone: (601) 213-4426
Email: info@benchchem.com