

# Validating the Downstream Effects of Rineterkib with RNA-seq: A Comparative Guide

**Author:** BenchChem Technical Support Team. **Date:** December 2025

## Compound of Interest

Compound Name: *Rineterkib hydrochloride*

Cat. No.: *B15127272*

[Get Quote](#)

For Researchers, Scientists, and Drug Development Professionals

## Introduction

Rineterkib (also known as LTT462) is an orally available, dual inhibitor of RAF and extracellular signal-regulated kinases 1 and 2 (ERK1/2).[1][2] As a key component of the mitogen-activated protein kinase (MAPK) signaling cascade, the RAF/MEK/ERK pathway is a critical regulator of cell proliferation, differentiation, and survival. Its aberrant activation is a hallmark of many human cancers, making it a prime target for therapeutic intervention. Rineterkib has been investigated in a Phase I clinical trial for patients with advanced solid tumors harboring MAPK pathway alterations (NCT02711345), where it was found to be well-tolerated and demonstrated target engagement by reducing the expression of DUSP6, a downstream target of ERK signaling.[1][2]

This guide provides a framework for validating the downstream effects of Rineterkib using RNA sequencing (RNA-seq) and offers a comparative perspective against other MAPK pathway inhibitors. While specific, publicly available RNA-seq data for Rineterkib is limited, this document outlines the expected transcriptomic consequences of its dual inhibitory action based on studies of similar compounds and provides detailed experimental protocols for researchers seeking to conduct such validation.

## Mechanism of Action and Expected Downstream Effects

Rineterkib's dual inhibition of both RAF and ERK1/2 is expected to lead to a more profound and sustained suppression of the MAPK pathway compared to inhibitors that target a single node. This "vertical inhibition" strategy is designed to overcome feedback mechanisms that can lead to pathway reactivation and drug resistance.[3][4]

The expected downstream effects of Rineterkib, as would be validated by RNA-seq, include the differential expression of genes involved in:

- Cell Cycle Progression: Downregulation of cyclins and cyclin-dependent kinases (e.g., CCND1).
- Cell Proliferation and Survival: Downregulation of pro-proliferative and anti-apoptotic genes (e.g., MYC, FOSL1).[3][4]
- Apoptosis: Upregulation of pro-apoptotic genes.
- Cell Adhesion and Migration: Modulation of genes involved in epithelial-mesenchymal transition (EMT).[3]

## Comparative Performance with Alternative MAPK Pathway Inhibitors

A direct comparative analysis of Rineterkib with other MAPK pathway inhibitors using RNA-seq is not yet publicly available. However, based on the known mechanisms of different inhibitor classes, we can anticipate distinct transcriptomic signatures.

Inhibitor Class	Examples	Expected RNA-seq Profile	Advantages	Limitations
BRAF Inhibitors	Vemurafenib, Dabrafenib	Downregulation of MAPK pathway genes in BRAF-mutant cells.	High efficacy in BRAF V600-mutant tumors.	Can lead to paradoxical pathway activation in BRAF wild-type cells.
MEK Inhibitors	Trametinib, Cobimetinib	Downregulation of genes downstream of MEK.	Effective in some BRAF and RAS-mutant cancers.	Resistance can emerge through upstream pathway reactivation.
ERK Inhibitors	Ulixertinib, SCH772984	Direct suppression of ERK target genes.	Can overcome resistance to BRAF and MEK inhibitors.	Potential for on-target toxicities in normal tissues.
Dual RAF/ERK Inhibitors	Rineterkib	Potentially the most comprehensive suppression of MAPK pathway-responsive genes.	May prevent feedback activation and delay resistance.	Limited clinical data available; potential for broader toxicity profile.

## Experimental Protocols for RNA-seq Validation

The following provides a detailed methodology for validating the downstream effects of Rineterkib and comparing it to other MAPK inhibitors using RNA-seq.

### Cell Culture and Drug Treatment

- Cell Lines: Select a panel of cancer cell lines with known MAPK pathway alterations (e.g., KRAS-mutant NSCLC, BRAF-mutant melanoma).

- **Drug Treatment:** Treat cells with Rineterkib and comparator inhibitors (e.g., a selective BRAF inhibitor, a MEK inhibitor, and a selective ERK inhibitor) at various concentrations and time points. Include a vehicle control (e.g., DMSO).
- **Replicates:** Use a minimum of three biological replicates for each treatment condition.

## RNA Isolation and Quality Control

- **RNA Extraction:** Isolate total RNA from treated cells using a commercially available kit (e.g., RNeasy Mini Kit, Qiagen).
- **Quality Control:** Assess RNA integrity and concentration using a Bioanalyzer (Agilent) or similar instrument. An RNA Integrity Number (RIN) of >8 is recommended.

## RNA-seq Library Preparation and Sequencing

- **Library Preparation:** Prepare sequencing libraries from 1 µg of total RNA using a stranded mRNA-seq library preparation kit (e.g., TruSeq Stranded mRNA Library Prep Kit, Illumina).
- **Sequencing:** Sequence the prepared libraries on a high-throughput sequencing platform (e.g., Illumina NovaSeq) to a depth of at least 20 million reads per sample.

## Bioinformatic Analysis

- **Quality Control of Reads:** Use tools like FastQC to assess the quality of the raw sequencing reads.
- **Read Alignment:** Align the reads to a reference genome (e.g., human genome build GRCh38) using a splice-aware aligner such as STAR.
- **Gene Expression Quantification:** Quantify gene expression levels using tools like RSEM or featureCounts.
- **Differential Gene Expression Analysis:** Perform differential gene expression analysis between drug-treated and control samples using packages such as DESeq2 or edgeR in R.
- **Pathway Analysis:** Use tools like GSEA (Gene Set Enrichment Analysis) or Ingenuity Pathway Analysis (IPA) to identify the biological pathways and processes that are

significantly altered by the drug treatments.

## Visualizations

### Signaling Pathway

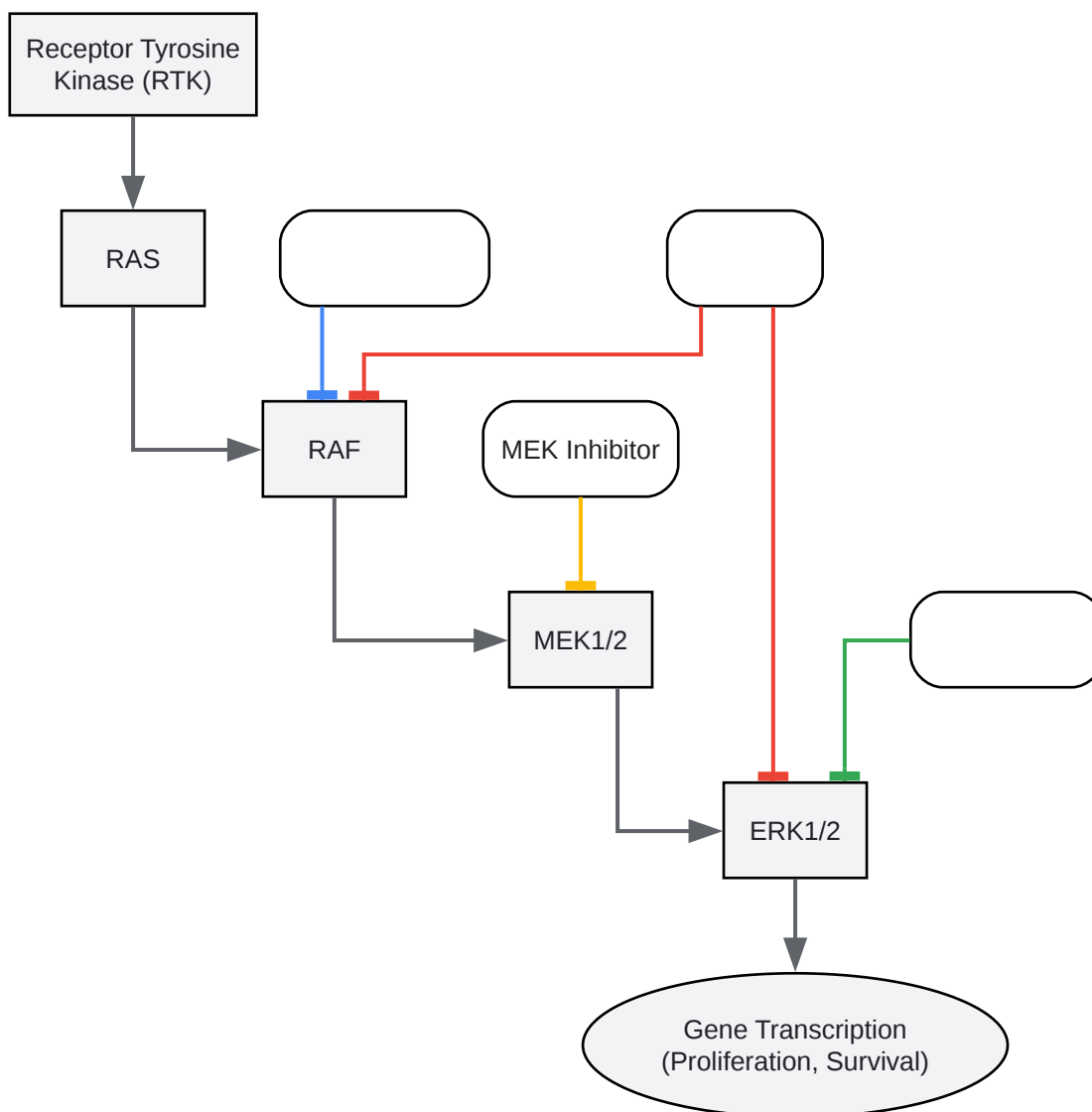

[Click to download full resolution via product page](#)

Caption: The MAPK signaling pathway and points of inhibition by various drugs.

## Experimental Workflow

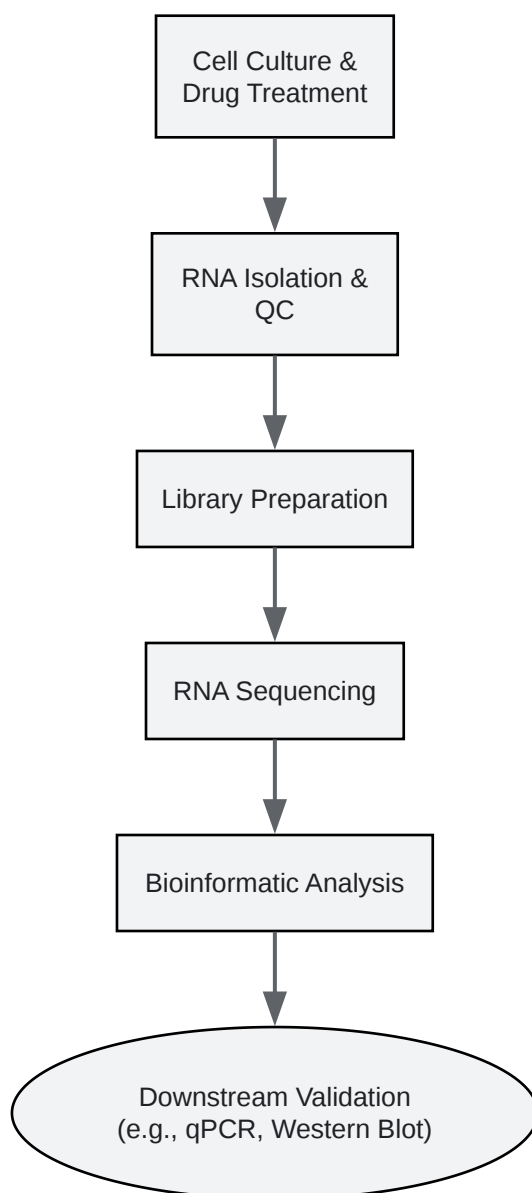

[Click to download full resolution via product page](#)

Caption: A generalized workflow for RNA-seq based validation of drug effects.

## Conclusion

RNA-seq is a powerful, unbiased tool for elucidating the genome-wide effects of targeted therapies like Rineterkib. While direct comparative RNA-seq data for Rineterkib is not yet prevalent in the public domain, the experimental framework outlined in this guide provides a robust methodology for its validation and comparison against other MAPK pathway inhibitors. The dual inhibitory mechanism of Rineterkib suggests the potential for a more profound and

durable suppression of the MAPK pathway, a hypothesis that can be rigorously tested using the described transcriptomic approaches. As more data from preclinical and clinical studies of Rineterkib become available, a clearer picture of its downstream effects and its place in the landscape of MAPK-targeted therapies will emerge.

#### *Need Custom Synthesis?*

*BenchChem offers custom synthesis for rare earth carbides and specific isotopic labeling.*

*Email: [info@benchchem.com](mailto:info@benchchem.com) or [Request Quote Online](#).*

## References

- 1. researchgate.net [researchgate.net]
- 2. ascopubs.org [ascopubs.org]
- 3. Low-Dose Vertical Inhibition of the RAF-MEK-ERK Cascade Causes Apoptotic Death of KRAS Mutant Cancers - PMC [pmc.ncbi.nlm.nih.gov]
- 4. Low-Dose Vertical Inhibition of the RAF-MEK-ERK Cascade Causes Apoptotic Death of KRAS Mutant Cancers - PubMed [pubmed.ncbi.nlm.nih.gov]
- To cite this document: BenchChem. [Validating the Downstream Effects of Rineterkib with RNA-seq: A Comparative Guide]. BenchChem, [2025]. [Online PDF]. Available at: [https://www.benchchem.com/product/b15127272#validating-the-downstream-effects-of-rineterkib-with-rna-seq]

---

#### **Disclaimer & Data Validity:**

The information provided in this document is for Research Use Only (RUO) and is strictly not intended for diagnostic or therapeutic procedures. While BenchChem strives to provide accurate protocols, we make no warranties, express or implied, regarding the fitness of this product for every specific experimental setup.

**Technical Support:** The protocols provided are for reference purposes. Unsure if this reagent suits your experiment? [[Contact our Ph.D. Support Team for a compatibility check](#)]

**Need Industrial/Bulk Grade?** [Request Custom Synthesis Quote](#)

# BenchChem

Our mission is to be the trusted global source of essential and advanced chemicals, empowering scientists and researchers to drive progress in science and industry.

## Contact

Address: 3281 E Guasti Rd

Ontario, CA 91761, United States

Phone: (601) 213-4426

Email: [info@benchchem.com](mailto:info@benchchem.com)