

Validating ML-9 Free Base Results: A Comparative Guide to Genetic Knockdowns

Author: BenchChem Technical Support Team. **Date:** December 2025

Compound of Interest

Compound Name: ML-9 free base

Cat. No.: B1676664

[Get Quote](#)

For Researchers, Scientists, and Drug Development Professionals: A Guide to Substantiating Small Molecule Inhibitor Data with Genetic Methods.

In the pursuit of understanding and modulating cellular processes, small molecule inhibitors are invaluable tools. **ML-9 free base** is a widely used inhibitor of Myosin Light Chain Kinase (MLCK), a key enzyme in the regulation of smooth muscle contraction, cell migration, and proliferation. However, the utility of any small molecule inhibitor is contingent on its specificity. To ensure that the observed biological effects of ML-9 are indeed due to the inhibition of MLCK and not off-target interactions, it is crucial to validate these findings with a more specific method, such as genetic knockdown of the MLCK gene.

This guide provides a comprehensive comparison of using **ML-9 free base** versus genetic knockdowns (siRNA/shRNA) to study MLCK function. It includes a summary of quantitative data, detailed experimental protocols for key validation experiments, and visualizations of the relevant biological pathways and experimental workflows.

Comparison of Pharmacological Inhibition and Genetic Knockdown

Feature	ML-9 Free Base (Pharmacological Inhibition)	Genetic Knockdown (siRNA/shRNA)
Mechanism of Action	Reversibly binds to the ATP-binding site of MLCK, inhibiting its kinase activity.	Degrades MLCK mRNA (siRNA) or inhibits its translation (shRNA), leading to reduced protein expression.
Specificity	Can exhibit off-target effects by inhibiting other kinases such as Protein Kinase A (PKA) and Protein Kinase C (PKC), as well as other proteins like STIM1. One study demonstrated that ML-9 can inhibit TRPC6 channels independently of MLCK.	Generally considered more specific to the target protein, though off-target effects due to unintended mRNA silencing can occur.
Kinetics	Rapid onset of action, with effects observable within minutes to hours of administration.	Slower onset, requiring 24-72 hours for significant protein depletion.
Reversibility	Effects are reversible upon removal of the compound.	Effects are long-lasting and, in the case of stable shRNA expression, can be permanent in a cell lineage.
Dosage/Efficiency	Effective concentrations typically range from 10-50 μ M in cell culture. The half-maximal inhibitory concentration (IC50) for MLCK is approximately 12.5 μ M in some assays.	Knockdown efficiency can vary, but often achieves >70% reduction in target protein expression as confirmed by Western blot.
Typical Applications	Acute studies, dose-response experiments, and initial target validation.	Validating findings from small molecule inhibitors, studying

the long-term consequences of protein loss.

Signaling Pathway and Experimental Validation

The following diagrams illustrate the MLCK signaling pathway and the workflow for validating ML-9's effects using genetic knockdowns.

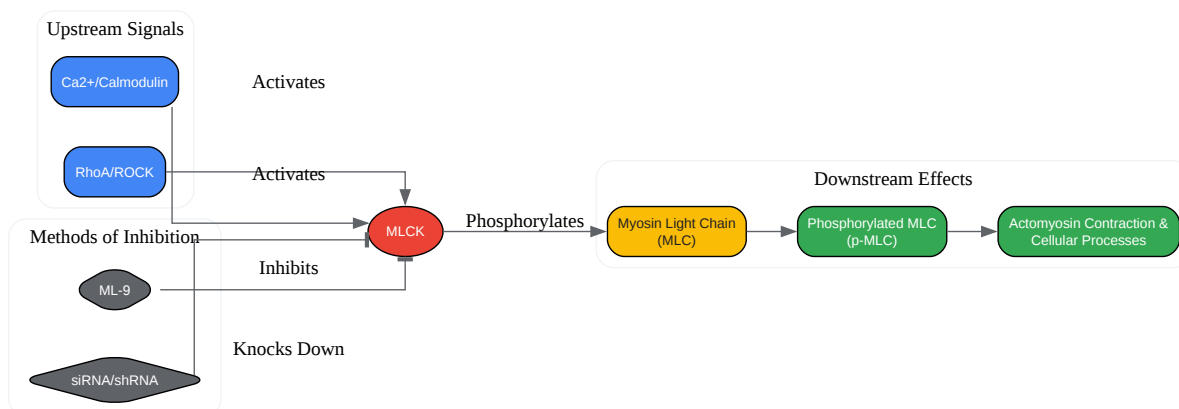

[Click to download full resolution via product page](#)

Caption: MLCK Signaling Pathway and Points of Intervention.

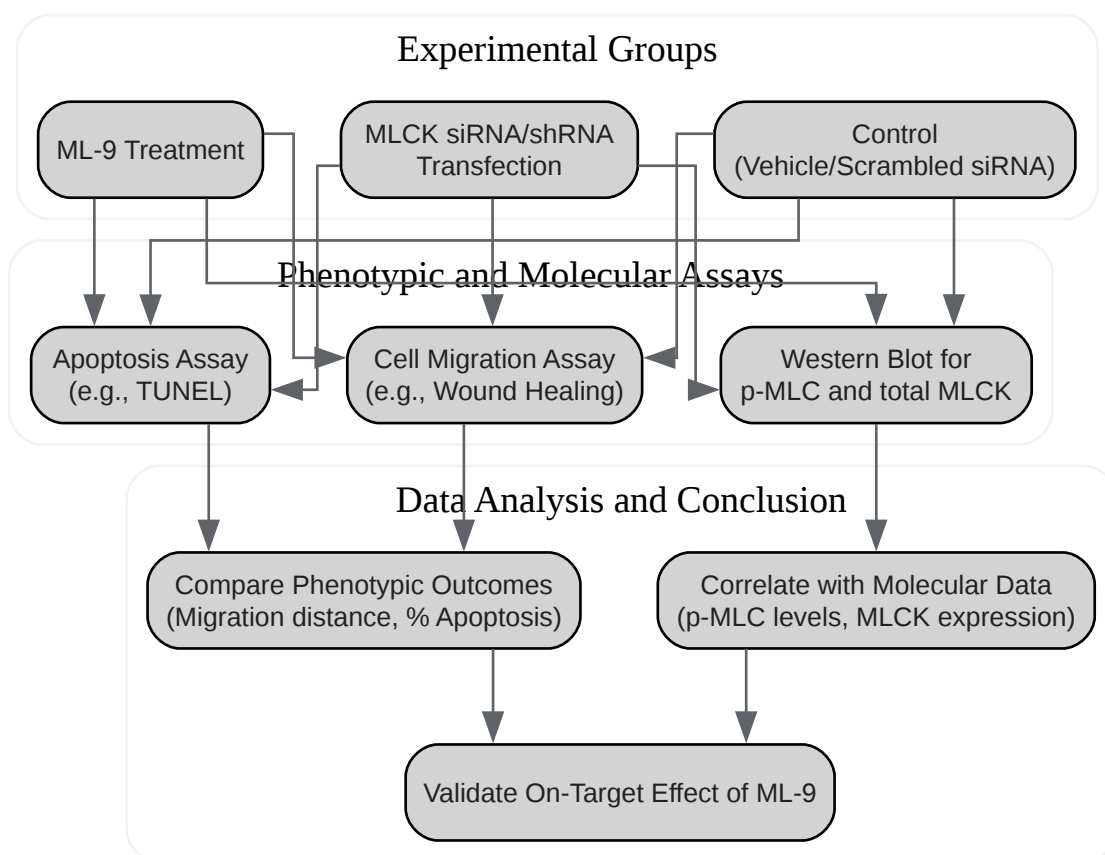

[Click to download full resolution via product page](#)

Caption: Experimental Workflow for Validating ML-9 Effects.

Experimental Protocols

Cell Culture and Treatment with ML-9 Free Base

- **Cell Seeding:** Plate cells at a density that will result in 70-80% confluency at the time of the experiment.
- **ML-9 Preparation:** Prepare a stock solution of **ML-9 free base** in an appropriate solvent (e.g., DMSO). Further dilute the stock solution in cell culture medium to the desired final concentrations (e.g., 10, 25, 50 μ M).
- **Treatment:** Replace the existing cell culture medium with the medium containing ML-9 or a vehicle control (medium with the same concentration of DMSO).

- Incubation: Incubate the cells for the desired period (e.g., 1, 4, 24 hours) before proceeding to downstream assays.

Genetic Knockdown of MLCK using siRNA

- siRNA Preparation: Resuspend lyophilized MLCK-specific siRNA and a non-targeting (scrambled) control siRNA in RNase-free water to create a stock solution.
- Transfection Reagent Preparation: In separate tubes, dilute the siRNA and a suitable transfection reagent (e.g., lipofectamine) in serum-free medium according to the manufacturer's instructions.
- Complex Formation: Combine the diluted siRNA and transfection reagent, mix gently, and incubate at room temperature to allow the formation of siRNA-lipid complexes.
- Transfection: Add the siRNA-lipid complexes to the cells in serum-free medium.
- Incubation: After a few hours of incubation, add serum-containing medium. Allow the cells to grow for 48-72 hours to ensure efficient knockdown of the target protein.
- Validation of Knockdown: Harvest the cells and perform Western blotting to confirm the reduction in MLCK protein levels compared to the scrambled siRNA control.

Western Blotting for MLCK and Phospho-MLC

- Cell Lysis: Wash the treated/transfected cells with ice-cold PBS and lyse them in a suitable lysis buffer containing protease and phosphatase inhibitors.
- Protein Quantification: Determine the protein concentration of each lysate using a protein assay (e.g., BCA assay).
- SDS-PAGE: Separate equal amounts of protein from each sample on an SDS-polyacrylamide gel.
- Protein Transfer: Transfer the separated proteins from the gel to a PVDF or nitrocellulose membrane.

- **Blocking:** Block the membrane with a suitable blocking buffer (e.g., 5% non-fat milk or BSA in TBST) to prevent non-specific antibody binding.
- **Primary Antibody Incubation:** Incubate the membrane with primary antibodies specific for MLCK, phospho-MLC (p-MLC), and a loading control (e.g., GAPDH or β -actin) overnight at 4°C.
- **Secondary Antibody Incubation:** Wash the membrane and incubate with an appropriate HRP-conjugated secondary antibody.
- **Detection:** Detect the protein bands using an enhanced chemiluminescence (ECL) substrate and an imaging system.
- **Quantification:** Quantify the band intensities using densitometry software and normalize to the loading control.

Cell Migration (Wound Healing) Assay

- **Create a Monolayer:** Grow cells to a confluent monolayer in a multi-well plate.
- **Create the "Wound":** Use a sterile pipette tip to create a scratch or "wound" in the center of the cell monolayer.
- **Treatment/Transfection:** For ML-9 experiments, replace the medium with fresh medium containing the desired concentration of ML-9 or vehicle. For knockdown experiments, perform the wound healing assay after 48-72 hours of transfection.
- **Imaging:** Capture images of the wound at time 0 and at regular intervals (e.g., every 8-12 hours) using a microscope.
- **Analysis:** Measure the width of the wound at different time points to determine the rate of cell migration and wound closure.

Apoptosis (TUNEL) Assay

- **Cell Preparation:** Culture and treat cells with ML-9 or transfect with siRNA as described above.

- **Fixation and Permeabilization:** Fix the cells with a cross-linking agent (e.g., paraformaldehyde) and then permeabilize them with a detergent (e.g., Triton X-100) to allow entry of the labeling reagents.
- **TUNEL Labeling:** Incubate the cells with a reaction mixture containing Terminal deoxynucleotidyl Transferase (TdT) and biotin-dUTP. TdT will add the labeled nucleotides to the 3'-OH ends of fragmented DNA, a hallmark of apoptosis.
- **Detection:** Add a streptavidin-HRP conjugate, which binds to the biotinylated nucleotides. Then, add a substrate for HRP (such as DAB) to generate a colored precipitate in apoptotic cells.
- **Microscopy:** Visualize the cells under a microscope. Apoptotic cells will have darkly stained nuclei.
- **Quantification:** Count the number of TUNEL-positive cells and express it as a percentage of the total number of cells to quantify the apoptotic rate.

Conclusion

The validation of data obtained using small molecule inhibitors like **ML-9 free base** with genetic knockdown techniques is a critical step in ensuring the reliability and specificity of research findings. While ML-9 is a valuable tool for studying the acute effects of MLCK inhibition, its potential for off-target effects necessitates confirmation of its on-target activity. Genetic knockdowns, by directly reducing the expression of the target protein, provide a more specific and complementary approach. By employing the comparative data and detailed protocols outlined in this guide, researchers can confidently validate their findings and contribute to a more robust understanding of MLCK's role in various biological processes.

- To cite this document: BenchChem. [Validating ML-9 Free Base Results: A Comparative Guide to Genetic Knockdowns]. BenchChem, [2025]. [Online PDF]. Available at: [<https://www.benchchem.com/product/b1676664#validating-ml-9-free-base-results-with-genetic-knockdowns>]

Disclaimer & Data Validity:

The information provided in this document is for Research Use Only (RUO) and is strictly not intended for diagnostic or therapeutic procedures. While BenchChem strives to provide accurate protocols, we make no warranties, express or implied, regarding the fitness of this product for every specific experimental setup.

Technical Support: The protocols provided are for reference purposes. Unsure if this reagent suits your experiment? [[Contact our Ph.D. Support Team for a compatibility check](#)]

Need Industrial/Bulk Grade? [Request Custom Synthesis Quote](#)

BenchChem

Our mission is to be the trusted global source of essential and advanced chemicals, empowering scientists and researchers to drive progress in science and industry.

Contact

Address: 3281 E Guasti Rd
Ontario, CA 91761, United States
Phone: (601) 213-4426
Email: info@benchchem.com