

Validating CHMFL-PI4K-127 Target Engagement in Plasmodium: A Comparative Guide

Author: BenchChem Technical Support Team. **Date:** December 2025

Compound of Interest

Compound Name: CHMFL-PI4K-127

Cat. No.: B10821518

[Get Quote](#)

For researchers, scientists, and drug development professionals, this guide provides a comprehensive comparison of methods to validate the target engagement of **CHMFL-PI4K-127**, a potent inhibitor of Plasmodium falciparum phosphatidylinositol 4-kinase (PfPI4K), against other notable PfPI4K inhibitors. This document outlines experimental data, detailed protocols for key assays, and visual workflows to facilitate a clear understanding of the available validation techniques.

CHMFL-PI4K-127 is a highly selective and potent inhibitor of PfPI4K, demonstrating significant activity against both the blood and liver stages of the Plasmodium parasite.^{[1][2][3][4]} Effective validation of its engagement with PfPI4K is crucial for advancing its development as a potential antimalarial therapeutic. This guide compares **CHMFL-PI4K-127** with other well-characterized PfPI4K inhibitors, such as MMV390048 and KAI407, across various target engagement assays.

Comparative Performance of PfPI4K Inhibitors

The following tables summarize the available quantitative data for **CHMFL-PI4K-127** and its key alternatives. This data provides a baseline for comparing their biochemical potency and cellular activity.

Table 1: Biochemical and Cellular Activity of PfPI4K Inhibitors

Compound	PfPI4K IC50 (nM)	<i>P. falciparum</i> EC50 (nM)	Reference(s)
CHMFL-PI4K-127	0.9	25.1	[3]
MMV390048	~3.4	28	
KAI407	-	~27-70	
UCT943	23 (PvPI4K)	6.9	

Note: IC50 values represent the concentration of the inhibitor required to reduce the enzymatic activity of PfPI4K by 50%. EC50 values represent the concentration required to inhibit the growth of *P. falciparum* in cellular assays by 50%. PvPI4K refers to *P. vivax* PI4K.

Experimental Protocols for Target Engagement Validation

Validating that a compound directly interacts with its intended target within the complex cellular environment of the parasite is a critical step in drug development. Several biophysical and cell-based assays can be employed for this purpose.

Cellular Thermal Shift Assay (CETSA)

CETSA is a powerful technique to assess target engagement in a cellular context. The principle is based on the ligand-induced stabilization of the target protein, leading to a higher melting temperature.

Detailed Protocol for CETSA in *P. falciparum*

This protocol is adapted from a comprehensive method published in Nature Protocols.

- Parasite Culture and Treatment:
 - Culture *P. falciparum*-infected erythrocytes to the desired stage (e.g., trophozoites).
 - Treat the infected red blood cells with a range of concentrations of the test compound (e.g., **CHMFL-PI4K-127**) or vehicle control (DMSO) for a defined period.

- Heat Treatment:
 - Aliquot the treated cell suspensions into PCR tubes.
 - Heat the samples across a range of temperatures (e.g., 40-70°C) for 3 minutes using a thermal cycler, followed by a 3-minute cooling step at 4°C.
- Lysis and Protein Solubilization:
 - Lyse the cells by freeze-thawing.
 - Separate the soluble protein fraction from the precipitated protein by centrifugation at high speed.
- Protein Quantification and Analysis:
 - Collect the supernatant containing the soluble proteins.
 - Denature and digest the proteins into peptides.
 - Analyze the peptide abundance using liquid chromatography-tandem mass spectrometry (LC-MS/MS).
- Data Analysis:
 - Generate melting curves by plotting the relative amount of soluble PfPI4K at each temperature.
 - The shift in the melting temperature (ΔT_m) in the presence of the compound compared to the vehicle control indicates target engagement.

Thermal Shift Assay (TSA) with Recombinant Protein

TSA, also known as differential scanning fluorimetry, provides a more direct measure of target engagement using purified recombinant protein.

Detailed Protocol for TSA with Recombinant PfPI4K

This protocol is based on generalized TSA procedures.

- Reaction Setup:
 - In a 96-well PCR plate, prepare a reaction mixture containing purified recombinant PfPI4K protein, a fluorescent dye that binds to hydrophobic regions of unfolded proteins (e.g., SYPRO Orange), and the test compound at various concentrations or a vehicle control.
 - Ensure the final buffer conditions are optimized for protein stability.
- Thermal Denaturation:
 - Place the plate in a real-time PCR instrument.
 - Apply a thermal ramp, gradually increasing the temperature from a baseline (e.g., 25°C) to a denaturing temperature (e.g., 95°C) with a slow ramp rate (e.g., 1°C/minute).
- Fluorescence Monitoring:
 - Continuously monitor the fluorescence intensity during the temperature ramp. As the protein unfolds, the dye binds to the exposed hydrophobic cores, causing an increase in fluorescence.
- Data Analysis:
 - Plot fluorescence intensity versus temperature to generate a melting curve.
 - The melting temperature (T_m) is the midpoint of the transition.
 - A positive shift in the T_m (ΔT_m) in the presence of the compound indicates stabilization of the protein and therefore direct binding.

Kinobeads Competition Binding Assay

This chemoproteomic approach is used to assess the selectivity of a kinase inhibitor across the kinome.

Detailed Protocol for Kinobeads Assay with *P. falciparum* Lysate

This protocol is based on methodologies used for MMV390048 target identification.

- Lysate Preparation:
 - Prepare a lysate from cultured *P. falciparum*-infected erythrocytes.
- Competition Binding:
 - Incubate the parasite lysate with the test compound (e.g., **CHMFL-PI4K-127**) at various concentrations.
- Kinobeads Pulldown:
 - Add kinobeads (sepharose beads coupled with broad-spectrum kinase inhibitors) to the lysate and incubate to allow binding of kinases.
- Washing and Elution:
 - Wash the beads to remove non-specifically bound proteins.
 - Elute the bound kinases from the beads.
- Proteomic Analysis:
 - Identify and quantify the eluted kinases using LC-MS/MS.
- Data Analysis:
 - A dose-dependent decrease in the amount of PfPI4K pulled down by the kinobeads in the presence of the test compound indicates that the compound is competing for the ATP-binding site of PfPI4K.

Visualizing Workflows and Pathways

Experimental Workflow for Target Validation

The following diagram illustrates the general workflow for validating the target engagement of a PfPI4K inhibitor.

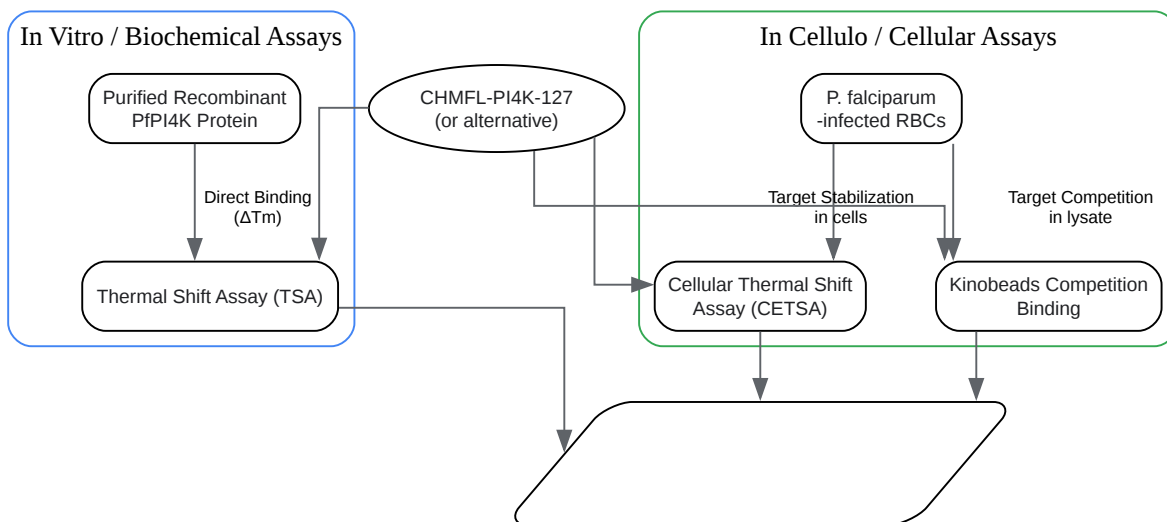

[Click to download full resolution via product page](#)

Caption: Workflow for validating PfPI4K inhibitor target engagement.

PfPI4K Signaling Pathway

Inhibition of PfPI4K disrupts the production of phosphatidylinositol 4-phosphate (PI4P), a crucial lipid second messenger. This disruption has downstream consequences on various cellular processes, including phospholipid biosynthesis, which is vital for parasite membrane formation and growth.

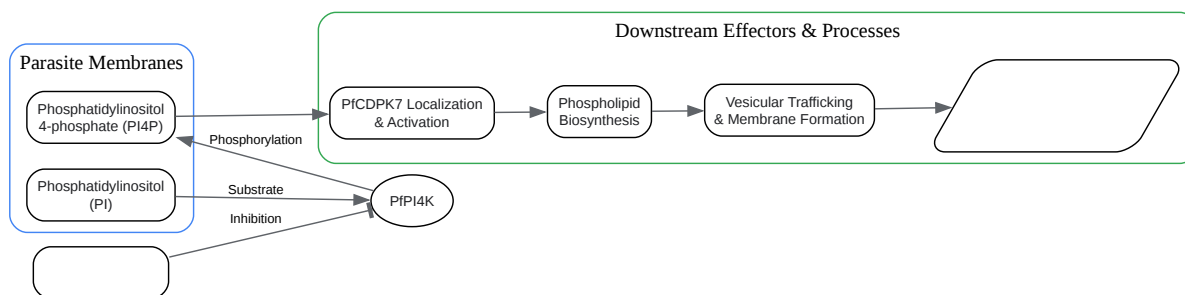

[Click to download full resolution via product page](#)

Caption: PfPI4K signaling pathway and its inhibition.

By employing the assays and understanding the pathways described in this guide, researchers can effectively validate the target engagement of **CHMFL-PI4K-127** and other PfPI4K inhibitors, contributing to the development of novel and potent antimalarial drugs.

Need Custom Synthesis?

BenchChem offers custom synthesis for rare earth carbides and specific isotopic labeling.

Email: info@benchchem.com or [Request Quote Online](#).

References

- 1. PI4-kinase and PfCDPK7 signaling regulate phospholipid biosynthesis in Plasmodium falciparum - PMC [pmc.ncbi.nlm.nih.gov]
- 2. Scientists Discover Novel Kinase Inhibitor Against Plasmodium----High Magnetic Field Laboratory, Chinese Academy of Sciences [english.hmfl.cas.cn]
- 3. Discovery of 6'-chloro-N-methyl-5'-(phenylsulfonamido)-[3,3'-bipyridine]-5-carboxamide (CHMFL-PI4K-127) as a novel Plasmodium falciparum PI(4)K inhibitor with potent antimalarial activity against both blood and liver stages of Plasmodium - PubMed [pubmed.ncbi.nlm.nih.gov]

- 4. malariaworld.org [malariaworld.org]
- To cite this document: BenchChem. [Validating CHMFL-PI4K-127 Target Engagement in Plasmodium: A Comparative Guide]. BenchChem, [2025]. [Online PDF]. Available at: [https://www.benchchem.com/product/b10821518#validating-chmfl-pi4k-127-target-engagement-in-plasmodium]

Disclaimer & Data Validity:

The information provided in this document is for Research Use Only (RUO) and is strictly not intended for diagnostic or therapeutic procedures. While BenchChem strives to provide accurate protocols, we make no warranties, express or implied, regarding the fitness of this product for every specific experimental setup.

Technical Support: The protocols provided are for reference purposes. Unsure if this reagent suits your experiment? [[Contact our Ph.D. Support Team for a compatibility check](#)]

Need Industrial/Bulk Grade? [Request Custom Synthesis Quote](#)

BenchChem

Our mission is to be the trusted global source of essential and advanced chemicals, empowering scientists and researchers to drive progress in science and industry.

Contact

Address: 3281 E Guasti Rd

Ontario, CA 91761, United States

Phone: (601) 213-4426

Email: info@benchchem.com