

Using Luffariellolide as a Tool for Studying Inflammation: Application Notes and Protocols

Author: BenchChem Technical Support Team. **Date:** December 2025

Compound of Interest

Compound Name: Luffariellolide

Cat. No.: B1675421

[Get Quote](#)

For Researchers, Scientists, and Drug Development Professionals

Introduction: **Luffariellolide**, a sesterterpene isolated from the marine sponge *Luffariella* sp., has emerged as a valuable pharmacological tool for investigating inflammatory processes. Its primary mechanism of action is the inhibition of phospholipase A2 (PLA2), a critical enzyme in the inflammatory cascade. By modulating PLA2 activity, **luffariellolide** allows for the detailed study of downstream signaling events and the development of novel anti-inflammatory therapeutics. These application notes provide a comprehensive overview of **luffariellolide**'s mechanism, quantitative data on its activity, and detailed protocols for its use in inflammation research.

Mechanism of Action

Luffariellolide exerts its anti-inflammatory effects primarily through the potent and partially reversible inhibition of human synovial fluid phospholipase A2 (hs-PLA2)[1]. PLA2 enzymes are responsible for the hydrolysis of phospholipids at the sn-2 position, leading to the release of arachidonic acid and lysophospholipids. Arachidonic acid is a precursor for the synthesis of pro-inflammatory eicosanoids, including prostaglandins and leukotrienes, through the cyclooxygenase (COX) and lipoxygenase (LOX) pathways, respectively. By inhibiting PLA2, **luffariellolide** effectively blocks the initial step of the arachidonic acid cascade, thereby reducing the production of these key inflammatory mediators. While the primary target of **luffariellolide** is PLA2, its downstream effects consequently impact the entire inflammatory

response regulated by arachidonic acid metabolites. The direct effects of **luffariellolide** on other key inflammatory signaling pathways, such as the NF- κ B pathway, and the expression of enzymes like COX-2 and inducible nitric oxide synthase (iNOS), are not yet extensively documented in publicly available scientific literature.

Data Presentation

The following table summarizes the available quantitative data for **luffariellolide**'s biological activity.

Parameter	Value	Experimental Model	Reference
IC50 (hs-PLA2)	5 μ M	In vitro enzymatic assay	[1]
ED50	50 μ g/ear	Phorbol ester (PMA)-induced mouse ear edema	MedChemExpress Product Data
Cytotoxicity	Not extensively reported	Various cell lines	N/A

Mandatory Visualizations

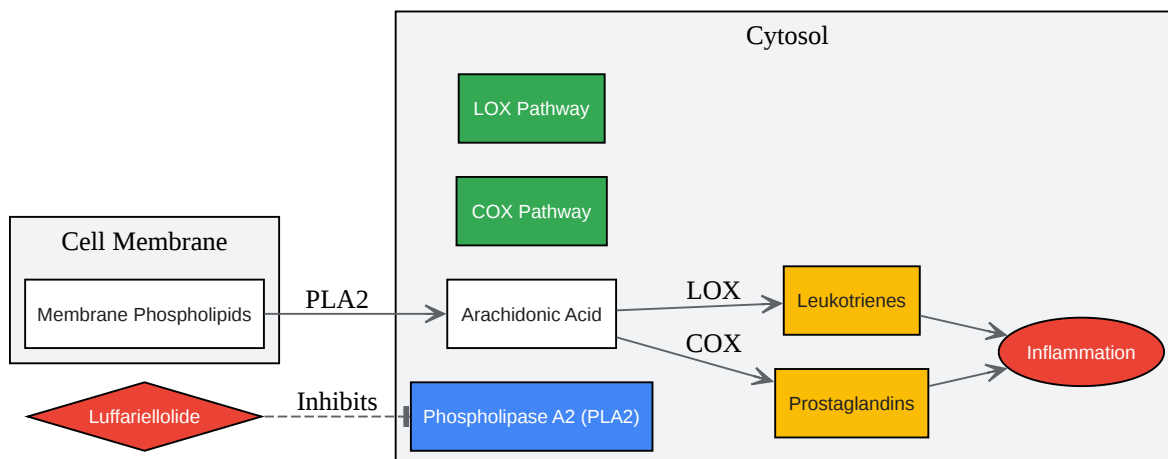

[Click to download full resolution via product page](#)

Caption: **Luffariellolide's** primary mechanism of action.

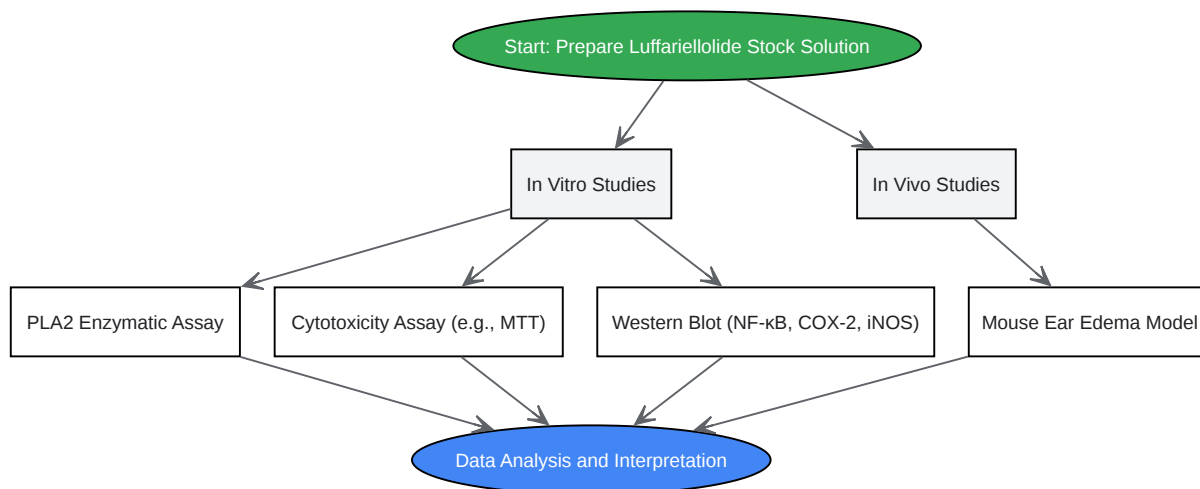

[Click to download full resolution via product page](#)

Caption: General experimental workflow for studying **luffariellolide**.

Experimental Protocols

Phospholipase A2 (PLA2) Inhibition Assay

This protocol is a generalized guide for a fluorometric PLA2 assay.

Materials:

- **Luffariellolide**
- Human synovial fluid PLA2 (hs-PLA2)
- Fluorescent PLA2 substrate (e.g., NBD-PC)
- Assay buffer (e.g., 50 mM Tris-HCl, 100 mM KCl, 1 mM CaCl₂, pH 8.0)
- 96-well black microplate
- Microplate reader with fluorescence detection capabilities

Procedure:

- Prepare **Luffariellolide** Dilutions: Prepare a stock solution of **luffariellolide** in DMSO. Serially dilute the stock solution in assay buffer to achieve a range of desired concentrations. Include a vehicle control (DMSO in assay buffer).
- Enzyme and Substrate Preparation: Dilute the hs-PLA2 enzyme to the working concentration in assay buffer. Prepare the fluorescent PLA2 substrate according to the manufacturer's instructions.
- Assay Reaction:
 - Add 20 μ L of each **luffariellolide** dilution or vehicle control to the wells of the 96-well plate.
 - Add 20 μ L of the diluted hs-PLA2 enzyme to each well and incubate for 15 minutes at room temperature to allow for inhibitor binding.

- Initiate the reaction by adding 160 μL of the fluorescent PLA2 substrate to each well.
- Measurement: Immediately begin monitoring the increase in fluorescence intensity at the appropriate excitation and emission wavelengths for the chosen substrate. Record measurements every minute for 30-60 minutes.
- Data Analysis: Calculate the rate of reaction for each concentration of **luffariellolide**. Determine the percentage of inhibition relative to the vehicle control. Plot the percentage of inhibition against the **luffariellolide** concentration and calculate the IC50 value using non-linear regression analysis.

Phorbol Ester-Induced Mouse Ear Edema Model

This protocol describes a common in vivo model for acute inflammation.

Materials:

- **Luffariellolide**
- Phorbol 12-myristate 13-acetate (PMA)
- Acetone (vehicle)
- Male Swiss mice (20-25 g)
- Micropipettes
- Biopsy punch (6 mm)
- Analytical balance

Procedure:

- Animal Acclimatization: Acclimate mice to the laboratory conditions for at least one week before the experiment.
- Preparation of Solutions: Dissolve PMA in acetone to a concentration of 2.5 $\mu\text{g}/20 \mu\text{L}$. Dissolve **luffariellolide** in acetone to achieve the desired doses (e.g., 10-100 $\mu\text{g}/20 \mu\text{L}$).

- Induction of Edema and Treatment:
 - Divide the mice into groups (n=5-8 per group): Vehicle control, PMA control, and **Luffariellolide**-treated groups.
 - Topically apply 20 μ L of the **luffariellolide** solution or vehicle to the inner and outer surfaces of the right ear of each mouse.
 - After 30 minutes, topically apply 20 μ L of the PMA solution to the same ear. The left ear serves as an internal control.
- Assessment of Edema: After 4-6 hours, sacrifice the mice by cervical dislocation.
 - Using a biopsy punch, remove a 6 mm circular section from both the right (treated) and left (control) ears.
 - Weigh each ear punch immediately.
 - The degree of edema is calculated as the difference in weight between the right and left ear punches.
- Data Analysis: Calculate the percentage of inhibition of edema for each treatment group compared to the PMA control group. Determine the ED50 value by plotting the percentage of inhibition against the **luffariellolide** dose.

Cell Viability (MTT) Assay

This protocol assesses the cytotoxicity of **luffariellolide** on cultured cells.

Materials:

- **Luffariellolide**
- Mammalian cell line (e.g., RAW 264.7 macrophages)
- Complete cell culture medium

- MTT (3-(4,5-dimethylthiazol-2-yl)-2,5-diphenyltetrazolium bromide) solution (5 mg/mL in PBS)
- Solubilization solution (e.g., DMSO or 0.01 M HCl in 10% SDS)
- 96-well cell culture plate
- Microplate reader

Procedure:

- Cell Seeding: Seed cells into a 96-well plate at a density of 1×10^4 to 5×10^4 cells/well in 100 μ L of complete medium and incubate for 24 hours.
- Treatment: Prepare serial dilutions of **luffariellolide** in cell culture medium. Remove the old medium from the cells and add 100 μ L of the **luffariellolide** dilutions or vehicle control.
- Incubation: Incubate the plate for 24-48 hours.
- MTT Addition: Add 10 μ L of MTT solution to each well and incubate for 2-4 hours at 37°C, allowing viable cells to form formazan crystals.
- Solubilization: Carefully remove the medium and add 100 μ L of solubilization solution to each well to dissolve the formazan crystals.
- Measurement: Measure the absorbance at 570 nm using a microplate reader.
- Data Analysis: Calculate the percentage of cell viability for each treatment relative to the vehicle control. Determine the IC50 value for cytotoxicity if a dose-dependent effect is observed.

Western Blot Analysis for NF- κ B, COX-2, and iNOS

This protocol can be used to investigate the effect of **luffariellolide** on the expression of key inflammatory proteins.

Materials:

- **Luffariellolide**
- RAW 264.7 macrophages
- Lipopolysaccharide (LPS)
- Cell lysis buffer (e.g., RIPA buffer with protease and phosphatase inhibitors)
- Protein assay kit (e.g., BCA)
- SDS-PAGE gels and running buffer
- Transfer buffer and PVDF membrane
- Blocking buffer (e.g., 5% non-fat milk or BSA in TBST)
- Primary antibodies (anti-p65, anti-COX-2, anti-iNOS, anti- β -actin)
- HRP-conjugated secondary antibody
- Chemiluminescent substrate
- Imaging system

Procedure:

- **Cell Treatment:** Seed RAW 264.7 cells and allow them to adhere. Pre-treat the cells with various concentrations of **luffariellolide** for 1 hour, followed by stimulation with LPS (e.g., 1 μ g/mL) for the appropriate time to induce protein expression (e.g., 24 hours for COX-2 and iNOS, shorter for p65 nuclear translocation).
- **Protein Extraction:** Wash the cells with cold PBS and lyse them with lysis buffer. Collect the lysates and determine the protein concentration.
- **SDS-PAGE and Western Blotting:**
 - Load equal amounts of protein onto an SDS-PAGE gel and perform electrophoresis.
 - Transfer the separated proteins to a PVDF membrane.

- Block the membrane with blocking buffer for 1 hour at room temperature.
- Incubate the membrane with the primary antibody overnight at 4°C.
- Wash the membrane and incubate with the HRP-conjugated secondary antibody for 1 hour at room temperature.
- Detection: Wash the membrane and add the chemiluminescent substrate. Capture the signal using an imaging system.
- Data Analysis: Quantify the band intensities and normalize them to the loading control (β -actin). Compare the protein expression levels in **luffariellolide**-treated cells to the LPS-stimulated control.

Need Custom Synthesis?

BenchChem offers custom synthesis for rare earth carbides and specific isotopic labeling.

Email: info@benchchem.com or [Request Quote Online](#).

References

- 1. researchgate.net [researchgate.net]
- To cite this document: BenchChem. [Using Luffariellolide as a Tool for Studying Inflammation: Application Notes and Protocols]. BenchChem, [2025]. [Online PDF]. Available at: [<https://www.benchchem.com/product/b1675421#using-luffariellolide-as-a-tool-for-studying-inflammation>]

Disclaimer & Data Validity:

The information provided in this document is for Research Use Only (RUO) and is strictly not intended for diagnostic or therapeutic procedures. While BenchChem strives to provide accurate protocols, we make no warranties, express or implied, regarding the fitness of this product for every specific experimental setup.

Technical Support: The protocols provided are for reference purposes. Unsure if this reagent suits your experiment? [[Contact our Ph.D. Support Team for a compatibility check](#)]

Need Industrial/Bulk Grade? [Request Custom Synthesis Quote](#)

BenchChem

Our mission is to be the trusted global source of essential and advanced chemicals, empowering scientists and researchers to drive progress in science and industry.

Contact

Address: 3281 E Guasti Rd
Ontario, CA 91761, United States
Phone: (601) 213-4426
Email: info@benchchem.com