

# Using Eperezolid in Cell-Free Transcription-Translation Assays: Application Notes and Protocols

**Author:** BenchChem Technical Support Team. **Date:** December 2025

## Compound of Interest

Compound Name: *Eperezolid*

Cat. No.: *B1671371*

[Get Quote](#)

For Researchers, Scientists, and Drug Development Professionals

## Introduction

**Eperezolid** is a member of the oxazolidinone class of antibiotics, which are potent inhibitors of bacterial protein synthesis. This unique mechanism of action makes them effective against a range of Gram-positive bacteria, including multidrug-resistant strains. Cell-free transcription-translation (TX-TL) systems have emerged as powerful platforms for studying the mechanism of action of such antibiotics and for high-throughput screening of new antimicrobial compounds. These systems, derived from bacterial lysates, contain all the necessary machinery for gene expression in a test tube, offering a rapid and controlled environment for studying antibiotic effects on transcription and translation.

This document provides detailed application notes and protocols for utilizing **eperezolid** in *Escherichia coli* and *Staphylococcus aureus* cell-free TX-TL assays. It includes information on the mechanism of action, quantitative data on its inhibitory effects, and step-by-step experimental procedures.

## Mechanism of Action of Eperezolid

**Eperezolid** exerts its antibacterial effect by inhibiting the initiation phase of protein synthesis.<sup>[1]</sup> It specifically binds to the 50S ribosomal subunit, preventing the formation of the initiation

complex, which is a crucial step for the commencement of translation.[2][3] Studies have shown that **eperezolid** binds near the peptidyl transferase center on the 50S subunit and competes with the binding of other antibiotics like chloramphenicol and lincomycin.[2][4] However, unlike these antibiotics, **eperezolid** does not inhibit the peptidyl transferase reaction itself, indicating a distinct mechanistic action.[2][3] Resistance to **eperezolid** has been linked to modifications in the ribosome, further confirming the ribosome as its primary target.[5][6]

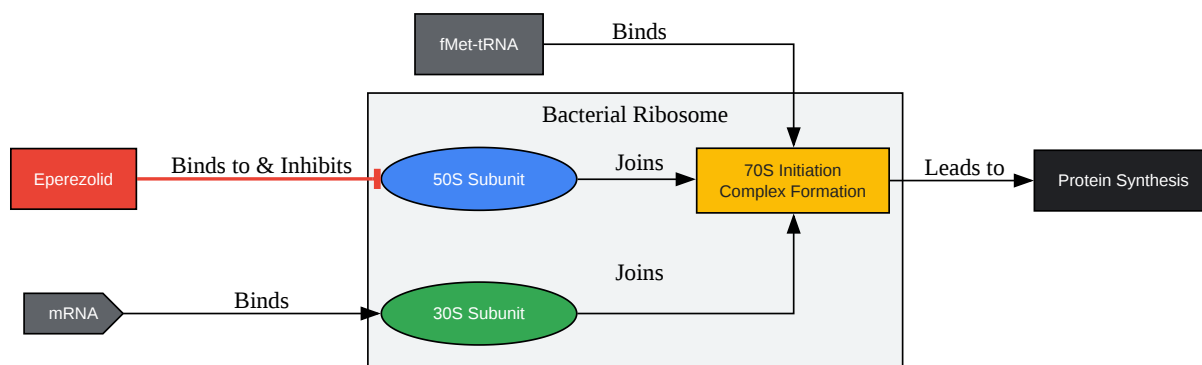

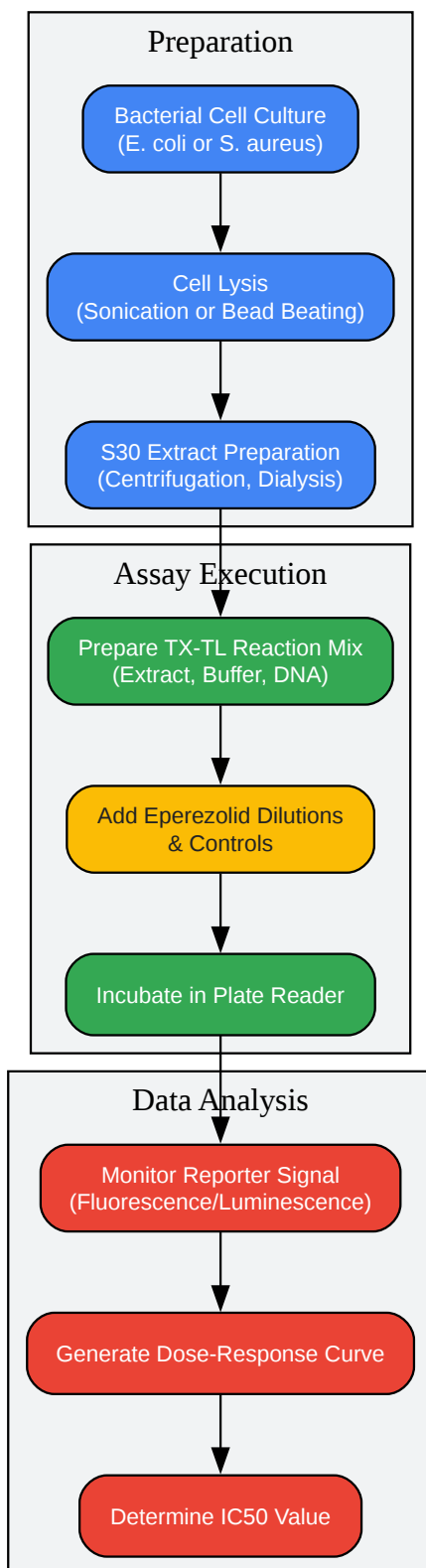

[Click to download full resolution via product page](#)

### Need Custom Synthesis?

BenchChem offers custom synthesis for rare earth carbides and specific isotopic labeling.

Email: [info@benchchem.com](mailto:info@benchchem.com) or [Request Quote Online](#).

## References

- 1. journals.plos.org [journals.plos.org]
- 2. assets.fishersci.com [assets.fishersci.com]
- 3. pubs.acs.org [pubs.acs.org]
- 4. youtube.com [youtube.com]
- 5. Translation inhibition and resource balance in the TX-TL cell-free gene expression system - PMC [pmc.ncbi.nlm.nih.gov]
- 6. A bacterial reporter panel for the detection and classification of antibiotic substances - PMC [pmc.ncbi.nlm.nih.gov]
- To cite this document: BenchChem. [Using Eperezolid in Cell-Free Transcription-Translation Assays: Application Notes and Protocols]. BenchChem, [2025]. [Online PDF]. Available at: [https://www.benchchem.com/product/b1671371#using-eperezolid-in-cell-free-transcription-translation-assays]

---

### Disclaimer & Data Validity:

The information provided in this document is for Research Use Only (RUO) and is strictly not intended for diagnostic or therapeutic procedures. While BenchChem strives to provide accurate protocols, we make no warranties, express or implied, regarding the fitness of this product for every specific experimental setup.

**Technical Support:** The protocols provided are for reference purposes. Unsure if this reagent suits your experiment? [[Contact our Ph.D. Support Team for a compatibility check](#)]

**Need Industrial/Bulk Grade?** [Request Custom Synthesis Quote](#)

# BenchChem

Our mission is to be the trusted global source of essential and advanced chemicals, empowering scientists and researchers to drive progress in science and industry.

## Contact

Address: 3281 E Guasti Rd

Ontario, CA 91761, United States

Phone: (601) 213-4426

Email: [info@benchchem.com](mailto:info@benchchem.com)