

Using Cyanide as an Inhibitor in Mitochondrial Studies: Application Notes and Protocols

Author: BenchChem Technical Support Team. **Date:** December 2025

Compound of Interest

Compound Name: Cyanide ion

Cat. No.: B1197471

[Get Quote](#)

For Researchers, Scientists, and Drug Development Professionals

Introduction

Cyanide is a potent and rapidly acting inhibitor of mitochondrial respiration, making it a valuable tool in cellular and molecular biology research. By specifically targeting Complex IV (Cytochrome c oxidase) of the electron transport chain (ETC), cyanide effectively halts aerobic respiration and oxidative phosphorylation.[1][2][3][4][5] This specific mechanism of action allows researchers to investigate a wide range of cellular processes that are dependent on mitochondrial function, including ATP production, mitochondrial membrane potential, and the induction of specific cell death pathways.[3][6] These application notes provide an overview of the use of cyanide in mitochondrial studies, including its mechanism of action, key experimental protocols, and expected quantitative outcomes.

Mechanism of Action

Cyanide, in its hydrogen cyanide (HCN) form, is a small, uncharged molecule that readily diffuses across the outer and inner mitochondrial membranes.[7] Once inside the mitochondrial matrix, the **cyanide ion** (CN⁻) binds to the ferric iron (Fe³⁺) in the heme a₃ component of Cytochrome c oxidase (Complex IV).[5][7] This binding prevents the transfer of electrons from cytochrome c to oxygen, the final electron acceptor in the ETC.[3][4] The inhibition of Complex IV has several immediate consequences:

- **Cessation of Electron Flow:** The entire electron transport chain backs up, leading to a halt in the flow of electrons.
- **Inhibition of Oxidative Phosphorylation:** The proton pumping activity of the ETC is stopped, preventing the generation of the proton motive force required for ATP synthesis by ATP synthase.
- **Increased Production of Reactive Oxygen Species (ROS):** The backup of electrons can lead to increased production of superoxide radicals at Complex I and Complex III.[3]
- **Cellular Hypoxia:** Despite normal oxygen levels, cells are unable to utilize it for energy production, leading to a state of histotoxic hypoxia.[7]

Interestingly, the effect of cyanide on Complex IV can be biphasic. While high micromolar to millimolar concentrations are strongly inhibitory, low nanomolar to micromolar concentrations have been reported to stimulate Complex IV activity and cell proliferation in some studies.[8][9][10][11]

Data Presentation

The following tables summarize quantitative data on the effects of cyanide in various experimental models.

Table 1: Inhibitory Concentrations (IC50) of Cyanide on Mitochondrial Respiration

Cell Type/Model	Parameter Measured	IC50 Value	Reference
Rat N27 Mesencephalic Cells	State-3 Oxygen Consumption	13.2 ± 1.8 μM	[4]
Rat N27 Mesencephalic Cells	Cytochrome c Oxidase (CcOX) Activity	7.2 ± 0.1 μM	[4]
Beef Heart Mitochondria	NADH-oxidase Activity	Varies by flavonoid co-treatment	[12]

Table 2: Effects of Cyanide on Mitochondrial Oxygen Consumption Rate (OCR)

Cell/Tissue Type	Cyanide Concentration	Effect on OCR	Quantitative Change	Reference
Human Peripheral Blood Mononuclear Cells (PBMCs)	Not specified	Decrease in Routine Respiration	Mean difference of 8.9 pmol O ₂ /s/10 ⁶ cells	[1]
Human Peripheral Blood Mononuclear Cells (PBMCs)	Not specified	Decrease in Maximal Respiration	Mean difference of 21.7 pmol O ₂ /s/10 ⁶ cells	[1]
HepG2 Cells	0.1 nM - 1 μM	Stimulation of Oxygen Consumption	Increase in OCR	[9][10]
HepG2 Cells	≥ 10 μM	Inhibition of Oxygen Consumption	Decrease in OCR	[9][10]
Mouse Liver Mitochondria	100 μM	Inhibition of TMPD-ascorbate driven respiration	Significant decrease	[6]

 Table 3: Effects of Cyanide on Mitochondrial Membrane Potential ($\Delta\Psi_m$)

Cell/Tissue Type	Cyanide Concentration	Effect on $\Delta\Psi_m$	Observation	Reference
Isolated Rat Liver Mitochondria	Millimolar concentrations	Attenuation of uncoupler (FCCP, DNP) induced depolarization	Cyanide diminished the ability of uncouplers to reduce $\Delta\Psi_m$	[5][13]
Primary Rat Cortical Cells	400 μ M (with UCP-2 overexpression)	Marked reduction	Potentiated loss of $\Delta\Psi_m$ leading to necrosis	[3]

Experimental Protocols

Important Safety Note: Cyanide and its salts are extremely toxic. All handling must be performed in a certified chemical fume hood with appropriate personal protective equipment (PPE), including gloves, lab coat, and safety glasses. Follow all institutional safety guidelines for the use and disposal of cyanide.

Protocol 1: Measurement of Mitochondrial Respiration using High-Resolution Respirometry (e.g., Seahorse XF Analyzer)

This protocol outlines the general steps for measuring the effect of cyanide on cellular oxygen consumption rates.

Materials:

- Cell culture medium
- Seahorse XF Cell Culture Microplates
- Seahorse XF Calibrant
- Potassium cyanide (KCN) or Sodium cyanide (NaCN) stock solution

- Oligomycin (Complex V inhibitor)
- FCCP (uncoupler)
- Rotenone (Complex I inhibitor) & Antimycin A (Complex III inhibitor)
- High-resolution respirometer (e.g., Seahorse XF Analyzer)

Procedure:

- Cell Seeding: Seed cells in a Seahorse XF Cell Culture Microplate at a predetermined optimal density and allow them to adhere overnight.[14][15]
- Incubation with Cyanide: On the day of the assay, replace the culture medium with fresh, pre-warmed assay medium containing the desired concentrations of cyanide. Include a vehicle control. Incubate for the desired duration (e.g., 1-4 hours) at 37°C in a CO₂-free incubator.
- Instrument Setup: Hydrate the sensor cartridge of the Seahorse XF Analyzer with the Seahorse XF Calibrant overnight at 37°C in a CO₂-free incubator.[15] Load the inhibitor port plate with oligomycin, FCCP, and a mixture of rotenone and antimycin A.
- Respirometry Measurement:
 - Place the cell culture microplate in the Seahorse XF Analyzer.
 - Initiate the assay protocol. The instrument will first measure the basal oxygen consumption rate (OCR).
 - Sequential injections of the inhibitors will occur to measure key parameters of mitochondrial function:
 - Oligomycin: Injected to inhibit ATP synthase, the subsequent OCR represents proton leak.
 - FCCP: Injected to uncouple the electron transport chain, inducing the maximal respiration rate.

- Rotenone & Antimycin A: Injected to shut down mitochondrial respiration completely, the remaining OCR is due to non-mitochondrial oxygen consumption.[14]
- Data Analysis: Normalize the OCR data to cell number or protein content. Analyze the changes in basal respiration, ATP-linked respiration, maximal respiration, and spare respiratory capacity in cyanide-treated cells compared to controls.

Protocol 2: Assessment of Mitochondrial Membrane Potential ($\Delta\Psi_m$) using JC-1 and Flow Cytometry

This protocol describes the use of the fluorescent dye JC-1 to measure changes in mitochondrial membrane potential. In healthy cells with a high $\Delta\Psi_m$, JC-1 forms aggregates that fluoresce red. In apoptotic or metabolically stressed cells with a low $\Delta\Psi_m$, JC-1 remains as monomers and fluoresces green.

Materials:

- Cell culture medium
- JC-1 staining solution
- Phosphate-buffered saline (PBS)
- Trypsin-EDTA (for adherent cells)
- Flow cytometer
- Carbonyl cyanide m-chlorophenyl hydrazone (CCCP) or FCCP (as a positive control for depolarization)

Procedure:

- Cell Treatment: Culture cells to the desired confluency and treat with various concentrations of cyanide for the specified time. Include a vehicle control and a positive control (e.g., 20 μM CCCP for 1 hour).[16]
- Cell Harvesting (for adherent cells): Gently wash the cells with PBS and detach them using Trypsin-EDTA. Neutralize the trypsin with complete medium and centrifuge to pellet the cells.

- **JC-1 Staining:** Resuspend the cell pellet in pre-warmed medium or PBS containing JC-1 staining solution (typically 1-10 µg/mL).[16] Incubate at 37°C for 15-30 minutes in the dark.
- **Washing:** Centrifuge the cells and wash them twice with PBS to remove excess dye.
- **Flow Cytometry Analysis:** Resuspend the final cell pellet in PBS. Analyze the cells on a flow cytometer, exciting at 488 nm. Detect green fluorescence (typically in the FL1 channel, ~525 nm) and red fluorescence (typically in the FL2 channel, ~590 nm).
- **Data Interpretation:** A decrease in the red/green fluorescence intensity ratio indicates mitochondrial membrane depolarization.

Protocol 3: Cell Viability Assessment using MTT Assay

This colorimetric assay measures the metabolic activity of cells as an indicator of viability. Viable cells with active mitochondrial dehydrogenases reduce the yellow tetrazolium salt MTT to purple formazan crystals.

Materials:

- Cell culture medium
- MTT (3-(4,5-dimethylthiazol-2-yl)-2,5-diphenyltetrazolium bromide) solution (e.g., 5 mg/mL in PBS)
- Solubilization solution (e.g., 4 mM HCl, 0.1% NP40 in isopropanol, or acidified SDS)[17]
- 96-well cell culture plates
- Microplate reader

Procedure:

- **Cell Seeding and Treatment:** Seed cells in a 96-well plate and allow them to attach. Treat the cells with a range of cyanide concentrations for the desired duration.[18]
- **MTT Addition:** After the treatment period, add MTT solution to each well to a final concentration of 0.5 mg/mL.[17][19]

- Incubation: Incubate the plate at 37°C for 3-4 hours to allow for the formation of formazan crystals.[17][20]
- Solubilization: Carefully remove the medium and add the solubilization solution to each well to dissolve the formazan crystals.[17][20] Mix gently by pipetting or shaking on an orbital shaker for about 15 minutes.[17]
- Absorbance Measurement: Read the absorbance at a wavelength between 550 and 600 nm (e.g., 570 nm) using a microplate reader.[18][21]
- Data Analysis: Subtract the background absorbance from a cell-free control. Cell viability is proportional to the absorbance and can be expressed as a percentage of the vehicle-treated control.

Mandatory Visualizations

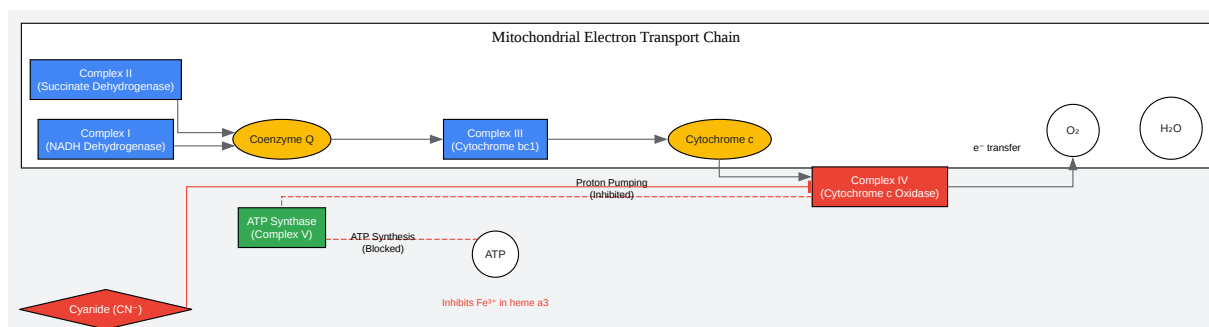

[Click to download full resolution via product page](#)

Caption: Mechanism of cyanide inhibition of the mitochondrial electron transport chain.

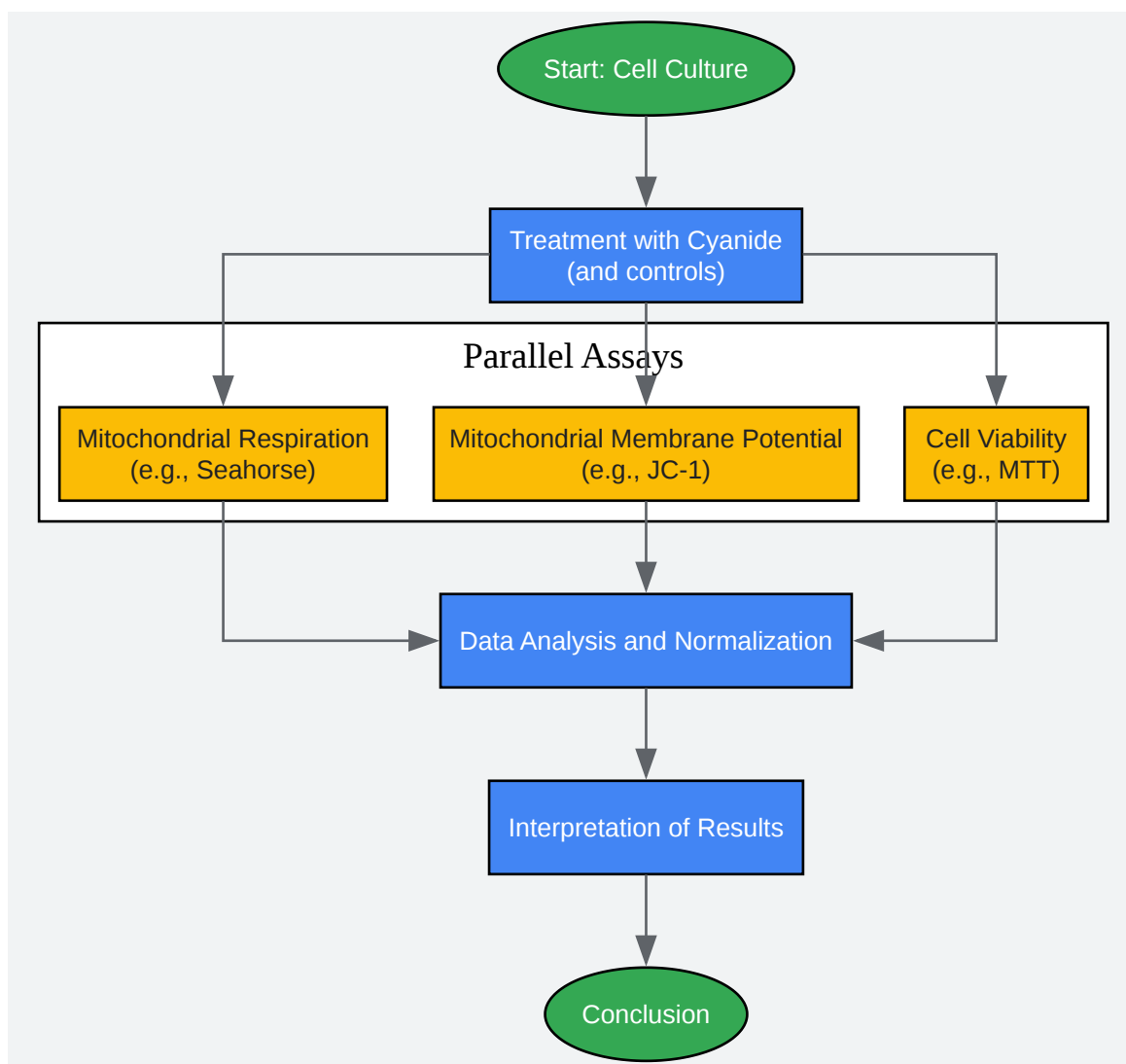

[Click to download full resolution via product page](#)

Caption: General experimental workflow for studying the effects of cyanide.

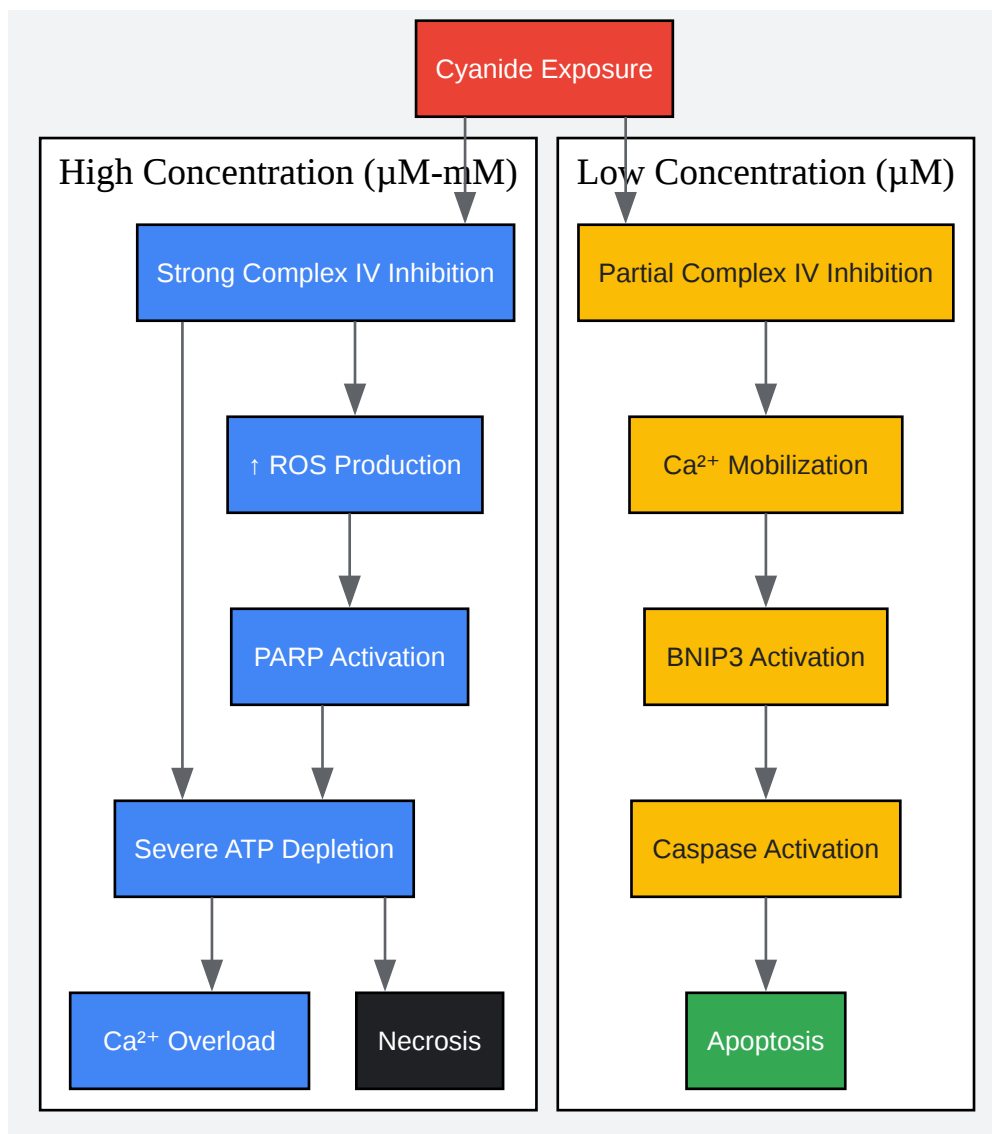

[Click to download full resolution via product page](#)

Caption: Signaling pathways affected by cyanide-induced mitochondrial dysfunction.

Need Custom Synthesis?

BenchChem offers custom synthesis for rare earth carbides and specific isotopic labeling.

Email: info@benchchem.com or [Request Quote Online](#).

References

- 1. Impairment of mitochondrial respiration following ex-vivo cyanide exposure in peripheral blood mononuclear cells - PMC [pmc.ncbi.nlm.nih.gov]
- 2. researchgate.net [researchgate.net]
- 3. academic.oup.com [academic.oup.com]
- 4. academic.oup.com [academic.oup.com]
- 5. Effect of Cyanide on Mitochondrial Membrane Depolarization Induced by Uncouplers - PubMed [pubmed.ncbi.nlm.nih.gov]
- 6. research.unipd.it [research.unipd.it]
- 7. droracle.ai [droracle.ai]
- 8. Cyanide Beyond Toxicity: A Systematic Review of Its Effects on Vascular Function - PMC [pmc.ncbi.nlm.nih.gov]
- 9. Physiological concentrations of cyanide stimulate mitochondrial Complex IV and enhance cellular bioenergetics - PMC [pmc.ncbi.nlm.nih.gov]
- 10. researchgate.net [researchgate.net]
- 11. The two faces of cyanide: an environmental toxin and a potential novel mammalian gasotransmitter - PMC [pmc.ncbi.nlm.nih.gov]
- 12. Inhibition of mitochondrial respiration and cyanide-stimulated generation of reactive oxygen species by selected flavonoids - PubMed [pubmed.ncbi.nlm.nih.gov]
- 13. researchgate.net [researchgate.net]
- 14. Protocol to assess changes in mitochondrial respiration in living cultured cells infected with flaviviruses - PMC [pmc.ncbi.nlm.nih.gov]
- 15. researchgate.net [researchgate.net]
- 16. A Flow Cytometry-based Assay for Measuring Mitochondrial Membrane Potential in Cardiac Myocytes After Hypoxia/Reoxygenation - PMC [pmc.ncbi.nlm.nih.gov]
- 17. MTT assay protocol | Abcam [abcam.com]
- 18. protocols.io [protocols.io]
- 19. merckmillipore.com [merckmillipore.com]
- 20. broadpharm.com [broadpharm.com]
- 21. Cell Viability Assays - Assay Guidance Manual - NCBI Bookshelf [ncbi.nlm.nih.gov]
- To cite this document: BenchChem. [Using Cyanide as an Inhibitor in Mitochondrial Studies: Application Notes and Protocols]. BenchChem, [2025]. [Online PDF]. Available at:

[<https://www.benchchem.com/product/b1197471#using-cyanide-as-an-inhibitor-in-mitochondrial-studies>]

Disclaimer & Data Validity:

The information provided in this document is for Research Use Only (RUO) and is strictly not intended for diagnostic or therapeutic procedures. While BenchChem strives to provide accurate protocols, we make no warranties, express or implied, regarding the fitness of this product for every specific experimental setup.

Technical Support: The protocols provided are for reference purposes. Unsure if this reagent suits your experiment? [[Contact our Ph.D. Support Team for a compatibility check](#)]

Need Industrial/Bulk Grade? [Request Custom Synthesis Quote](#)

BenchChem

Our mission is to be the trusted global source of essential and advanced chemicals, empowering scientists and researchers to drive progress in science and industry.

Contact

Address: 3281 E Guasti Rd
Ontario, CA 91761, United States
Phone: (601) 213-4426
Email: info@benchchem.com