

# Unveiling the Therapeutic Potential of Cajaninstilbene Acid Analogs: A Structure- Activity Relationship Guide

**Author:** BenchChem Technical Support Team. **Date:** December 2025

## Compound of Interest

Compound Name: *Cajaninstilbene acid*

Cat. No.: *B1242599*

[Get Quote](#)

For researchers, scientists, and drug development professionals, this guide provides a comprehensive comparison of **Cajaninstilbene acid (CSA)** analogs, detailing their structure-activity relationships across various biological activities. Supported by experimental data, this document aims to facilitate the development of novel therapeutic agents derived from this promising natural product scaffold.

**Cajaninstilbene acid (CSA)**, a stilbenoid isolated from the leaves of *Cajanus cajan* (pigeon pea), has garnered significant attention for its diverse pharmacological properties, including anticancer, anti-inflammatory, antioxidant, and antibacterial activities.<sup>[1][2][3]</sup> The structural backbone of CSA, characterized by a stilbene core with hydroxyl, carboxyl, methoxy, and prenyl groups, offers a versatile template for synthetic modification to enhance potency and selectivity.<sup>[1]</sup> This guide synthesizes the current understanding of the structure-activity relationships (SAR) of CSA analogs, presenting key quantitative data, detailed experimental protocols, and visual representations of the underlying molecular pathways.

## Antitumor Activity: Targeting Cancer's Core Pathways

CSA and its derivatives have demonstrated significant potential as anticancer agents, particularly against breast cancer.<sup>[1][4]</sup> The antitumor mechanism often involves the modulation

of critical signaling pathways, including the NF- $\kappa$ B, MAPK, and PI3K/Akt/mTOR pathways, leading to cell cycle arrest and apoptosis.[1][2]

## Comparative Efficacy of CSA Analogs in Cancer Cell Lines

The following table summarizes the cytotoxic activity of CSA and several of its key analogs against various cancer cell lines, providing a quantitative basis for SAR analysis.

Compound	Cell Line	Activity (IC <sub>50</sub> /EC <sub>50</sub> in $\mu$ M)	Reference
Cajaninstilbene acid (CSA)	MCF-7 (ER $\alpha$ -positive breast cancer)	61.25 $\pm$ 2.67	[1]
MDA-MB-231 (ER $\alpha$ -negative breast cancer)	175.76 $\pm$ 19.59	[1]	
Tamoxifen-resistant MCF-7	188.22 $\pm$ 38.58	[1]	
HeLa (Cervical cancer)	39 to >80 $\mu$ g/mL	[1]	
CaCo-2 (Colorectal cancer)	32 to >80 $\mu$ g/mL	[1]	
CSA derivative 6	MCF-7	2.96 $\pm$ 0.12	[1]
CSA derivative 19	HEK293 (c-Myc transfected)	1.40 $\pm$ 0.64	[1]
Longistylin A	Various tumor cell lines	Broad-spectrum activity	[1]
Longistylin C	Various tumor cell lines	Broad-spectrum activity	[1]

Structure-Activity Relationship Insights: The data suggests that the anti-estrogenic activity of CSA contributes significantly to its efficacy against ER $\alpha$ -positive breast cancer cells.[5] Synthetic modifications, as seen in derivatives 6 and 19, can dramatically enhance cytotoxic potency, with some analogs showing significantly lower EC<sub>50</sub> values for c-Myc inhibition compared to known inhibitors.[1] The natural derivatives, Longistylin A and C, also exhibit broad-spectrum antitumor activity, highlighting the therapeutic potential of the CSA scaffold.[1]

## Signaling Pathway Modulation

The antitumor effects of CSA analogs are intrinsically linked to their ability to interfere with key cellular signaling pathways that regulate cell proliferation, survival, and apoptosis.

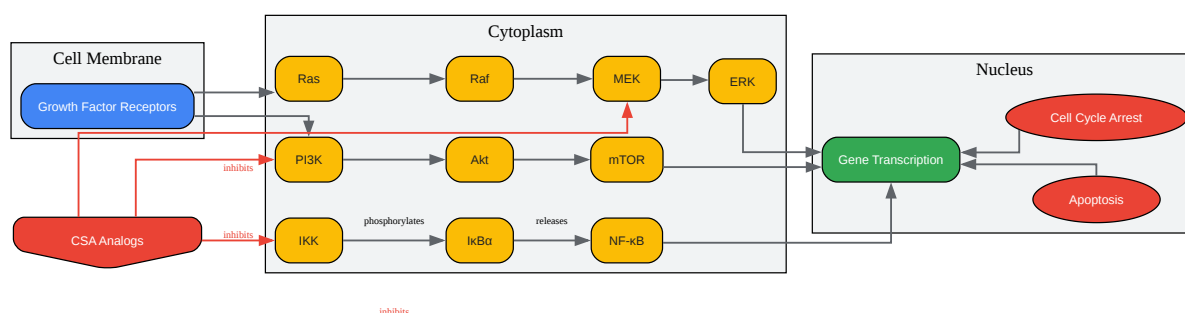

[Click to download full resolution via product page](#)

**Figure 1:** Antitumor signaling pathways modulated by CSA analogs.

## Anti-inflammatory Activity: Quelling the Inflammatory Cascade

Chronic inflammation is a hallmark of numerous diseases. CSA and its derivatives have demonstrated potent anti-inflammatory effects by inhibiting the production of key inflammatory mediators.[6]

## Inhibition of Inflammatory Mediators

The following table presents the inhibitory activity of CSA and its analogs on the production of nitric oxide (NO), tumor necrosis factor-alpha (TNF- $\alpha$ ), and interleukin-6 (IL-6) in lipopolysaccharide (LPS)-stimulated murine macrophages.

Compound	NO Inhibition (IC <sub>50</sub> in $\mu$ M)	TNF- $\alpha$ Inhibition (IC <sub>50</sub> in $\mu$ M)	IL-6 Inhibition (IC <sub>50</sub> in $\mu$ M)	Reference
Cajaninstilbene acid (CSA)	Strong inhibition	Strong inhibition	Strong inhibition	[6]
Derivative 5c	Strong inhibition	Strong inhibition	Strong inhibition	[6]
Derivative 5e	Strong inhibition	Strong inhibition	Strong inhibition	[6]
Derivative 5h	Strong inhibition	Strong inhibition	Strong inhibition	[6]

Structure-Activity Relationship Insights: Specific synthetic derivatives of CSA, such as 5c, 5e, and 5h, have been shown to exhibit strong inhibitory activity against the release of key pro-inflammatory molecules.[6] This suggests that modifications to the CSA scaffold can be tailored to optimize anti-inflammatory potency.

## NF- $\kappa$ B and MAPK Signaling Pathway Inhibition

The anti-inflammatory mechanism of CSA analogs is largely attributed to the inhibition of the NF- $\kappa$ B and MAPK signaling pathways.

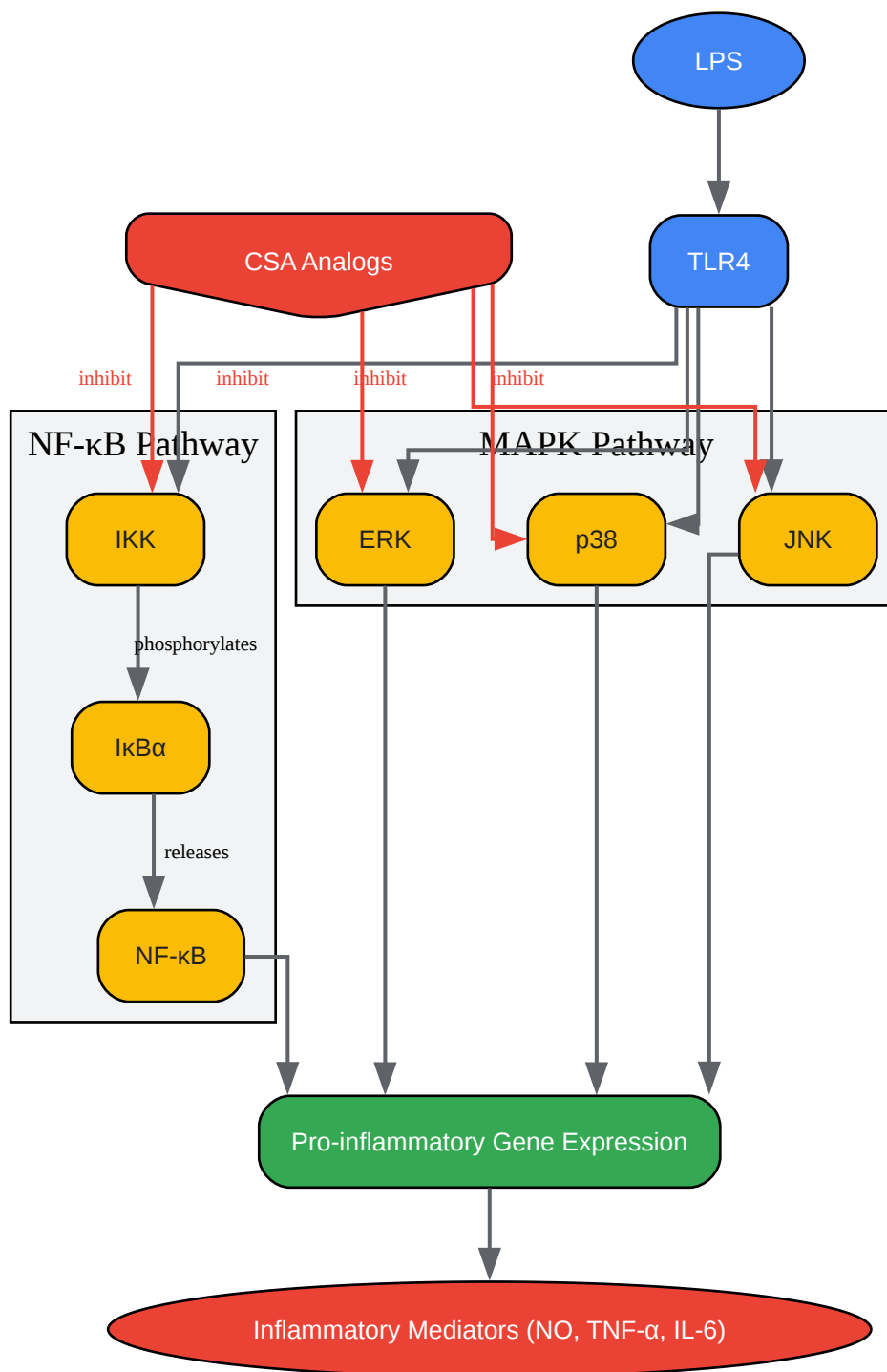

[Click to download full resolution via product page](#)

**Figure 2:** Anti-inflammatory signaling pathways inhibited by CSA analogs.

## Antibacterial Activity: Combating Drug-Resistant Pathogens

The emergence of antibiotic-resistant bacteria necessitates the discovery of novel antibacterial agents. CSA and its derivatives have shown promising activity against various bacterial strains, including methicillin-resistant *Staphylococcus aureus* (MRSA).

## Comparative Antibacterial Efficacy

The following table summarizes the minimum inhibitory concentration (MIC) of CSA and its analogs against different bacterial species.

Compound	Bacterial Strain	MIC ( $\mu\text{g/mL}$ )	Reference
Cajaninstilbene acid (CSA)	<i>S. aureus</i>	25	[7]
Derivative 5b	Gram-positive bacteria, MRSA	Potent activity	[8]
Derivative 5c	Gram-positive bacteria, MRSA	Potent activity	[8]
Derivative 5j	Gram-positive bacteria, MRSA	Potent activity	[8]
Derivative 5k	Gram-positive bacteria, MRSA	Potent activity	[8]

Structure-Activity Relationship Insights: Synthetic modifications have yielded CSA derivatives (5b, 5c, 5j, and 5k) with potent antibacterial activity against Gram-positive bacteria and MRSA, in some cases exceeding the efficacy of control antibiotics.[8] This highlights the potential of SAR-guided design to develop new classes of antibacterial drugs.

## Experimental Protocols

Detailed methodologies for the key experiments cited in this guide are provided below to ensure reproducibility and facilitate further research.

### Cytotoxicity Assay (MTT/XTT Assay)

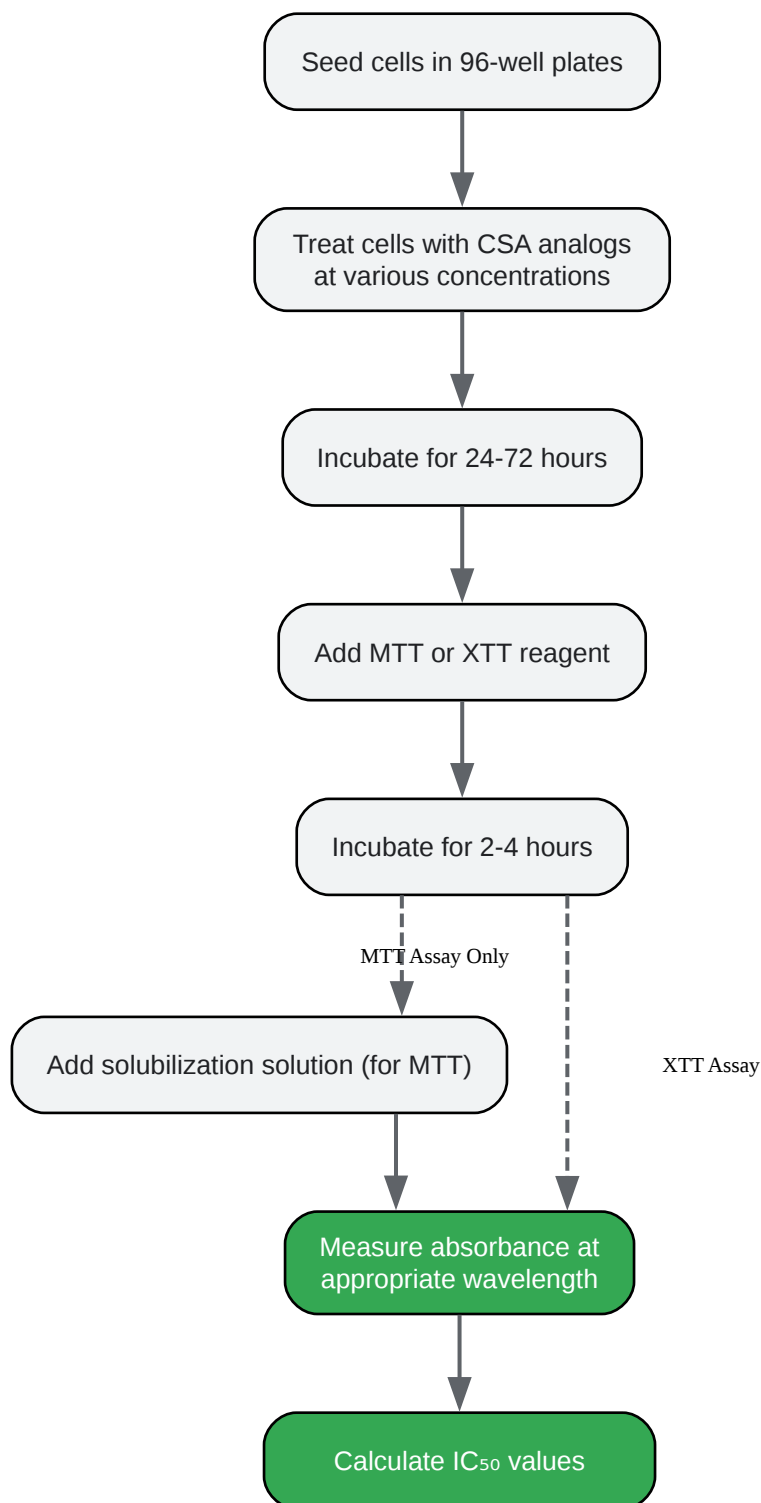

[Click to download full resolution via product page](#)

**Figure 3:** Workflow for MTT/XTT cytotoxicity assays.

Protocol:

- Cell Seeding: Plate cells in 96-well plates at a density of 5,000-10,000 cells per well and allow them to adhere overnight.
- Treatment: Treat the cells with serial dilutions of CSA analogs and a vehicle control.
- Incubation: Incubate the plates for the desired period (e.g., 24, 48, or 72 hours) at 37°C in a humidified CO<sub>2</sub> incubator.
- Reagent Addition: Add MTT (3-(4,5-dimethylthiazol-2-yl)-2,5-diphenyltetrazolium bromide) or XTT (2,3-bis-(2-methoxy-4-nitro-5-sulfophenyl)-2H-tetrazolium-5-carboxanilide) solution to each well.
- Incubation: Incubate for 2-4 hours to allow for the conversion of the tetrazolium salt to formazan by metabolically active cells.
- Solubilization (MTT only): If using MTT, add a solubilizing agent (e.g., DMSO or a specialized buffer) to dissolve the formazan crystals.
- Absorbance Measurement: Measure the absorbance of the wells using a microplate reader at the appropriate wavelength (e.g., 570 nm for MTT, 450 nm for XTT).
- Data Analysis: Calculate the half-maximal inhibitory concentration (IC<sub>50</sub>) values by plotting the percentage of cell viability against the logarithm of the compound concentration.

## Anti-inflammatory Assays (NO, TNF- $\alpha$ , and IL-6 Measurement)

Protocol:

- Cell Culture: Culture murine macrophage cells (e.g., RAW 264.7) in 96-well plates.
- Pre-treatment: Pre-treat the cells with various concentrations of CSA analogs for 1 hour.
- Stimulation: Stimulate the cells with lipopolysaccharide (LPS; 1  $\mu$ g/mL) for 24 hours to induce an inflammatory response.
- Nitric Oxide (NO) Measurement (Griess Assay):



- Collect the cell culture supernatant.
- Mix the supernatant with Griess reagent.
- Measure the absorbance at 540 nm.
- Determine the nitrite concentration from a standard curve.
- TNF- $\alpha$  and IL-6 Measurement (ELISA):
  - Use commercially available ELISA kits for TNF- $\alpha$  and IL-6.
  - Follow the manufacturer's instructions to measure the cytokine concentrations in the cell culture supernatant.

## Western Blotting for Signaling Pathway Analysis

Protocol:

- Cell Lysis: Lyse treated and untreated cells in RIPA buffer containing protease and phosphatase inhibitors.
- Protein Quantification: Determine the protein concentration of the lysates using a BCA or Bradford assay.
- SDS-PAGE: Separate equal amounts of protein on a sodium dodecyl sulfate-polyacrylamide gel.
- Protein Transfer: Transfer the separated proteins to a PVDF or nitrocellulose membrane.
- Blocking: Block the membrane with a blocking buffer (e.g., 5% non-fat milk or BSA in TBST) to prevent non-specific antibody binding.
- Primary Antibody Incubation: Incubate the membrane with primary antibodies specific for the target proteins (e.g., phospho-p65, total p65, phospho-ERK, total ERK) overnight at 4°C.
- Secondary Antibody Incubation: Wash the membrane and incubate with a horseradish peroxidase (HRP)-conjugated secondary antibody.

- Detection: Detect the protein bands using an enhanced chemiluminescence (ECL) substrate and visualize using an imaging system.
- Analysis: Quantify the band intensities and normalize to a loading control (e.g.,  $\beta$ -actin or GAPDH).

## Antibacterial Minimum Inhibitory Concentration (MIC) Assay

Protocol:

- Bacterial Culture: Grow the bacterial strains in an appropriate broth medium.
- Compound Dilution: Prepare serial twofold dilutions of the CSA analogs in a 96-well microtiter plate.
- Inoculation: Add a standardized bacterial inoculum to each well.
- Incubation: Incubate the plates at 37°C for 18-24 hours.
- MIC Determination: The MIC is defined as the lowest concentration of the compound that completely inhibits visible bacterial growth.

This guide provides a foundational understanding of the structure-activity relationships of **Cajaninstilbene acid** analogs. The presented data and protocols are intended to serve as a valuable resource for the scientific community to accelerate the discovery and development of novel therapeutics based on this versatile natural product scaffold.

### Need Custom Synthesis?

BenchChem offers custom synthesis for rare earth carbides and specific isotopic labeling.

Email: [info@benchchem.com](mailto:info@benchchem.com) or [Request Quote Online](#).

## References

- 1. CyQUANT XTT and MTT Assays for Cell Viability | Thermo Fisher Scientific - HK [thermofisher.com]
- 2. Cell Viability Assays - Assay Guidance Manual - NCBI Bookshelf [ncbi.nlm.nih.gov]
- 3. Evaluation of NF- $\kappa$ B/MAPK signaling pathway by western blotting [bio-protocol.org]
- 4. mjas.analis.com.my [mjas.analis.com.my]
- 5. NF- $\kappa$ B Pathway Antibody Sampler Kit | Cell Signaling Technology [cellsignal.com]
- 6. broadpharm.com [broadpharm.com]
- 7. Cajaninstilbene Acid and Its Derivative as Multi-Therapeutic Agents: A Comprehensive Review - PMC [pmc.ncbi.nlm.nih.gov]
- 8. Novel cajaninstilbene acid derivatives as antibacterial agents - PubMed [pubmed.ncbi.nlm.nih.gov]
- To cite this document: BenchChem. [Unveiling the Therapeutic Potential of Cajaninstilbene Acid Analogs: A Structure-Activity Relationship Guide]. BenchChem, [2025]. [Online PDF]. Available at: [https://www.benchchem.com/product/b1242599#structure-activity-relationship-of-cajaninstilbene-acid-analogs]

---

#### Disclaimer & Data Validity:

The information provided in this document is for Research Use Only (RUO) and is strictly not intended for diagnostic or therapeutic procedures. While BenchChem strives to provide accurate protocols, we make no warranties, express or implied, regarding the fitness of this product for every specific experimental setup.

**Technical Support:** The protocols provided are for reference purposes. Unsure if this reagent suits your experiment? [[Contact our Ph.D. Support Team for a compatibility check](#)]

**Need Industrial/Bulk Grade?** [Request Custom Synthesis Quote](#)

# BenchChem

Our mission is to be the trusted global source of essential and advanced chemicals, empowering scientists and researchers to drive progress in science and industry.

## Contact

Address: 3281 E Guasti Rd

Ontario, CA 91761, United States

Phone: (601) 213-4426

Email: [info@benchchem.com](mailto:info@benchchem.com)