

Unveiling the Molecular Architecture of Glomeratide A: A Technical Overview

Author: BenchChem Technical Support Team. **Date:** December 2025

Compound of Interest

Compound Name: *Glomeratide A*

Cat. No.: *B12385566*

[Get Quote](#)

For Researchers, Scientists, and Drug Development Professionals

Glomeratide A, a novel benzophenone C-glucoside, was first isolated from the whole plant of *Polygala glomerata* Lour. Its structural elucidation was accomplished through a comprehensive analysis of spectroscopic data, revealing a unique molecular framework. This document provides a technical guide to the methodologies and data integral to the determination of **Glomeratide A**'s chemical structure, based on the initial findings published by Li et al. in the *Journal of Asian Natural Products Research*, 2008.^{[1][2]}

While the complete, detailed experimental data from the primary literature is not publicly available, this guide reconstructs the likely methodologies and presents illustrative data based on established practices for the structural elucidation of natural products.

Isolation and Purification

The isolation of **Glomeratide A** from *Polygala glomerata* would typically involve a multi-step process to separate the compound from the complex mixture of plant metabolites.

Experimental Protocol: A Prototypical Approach

- **Extraction:** Dried and powdered whole plants of *Polygala glomerata* would be subjected to solvent extraction, likely using a moderately polar solvent such as methanol or ethanol, to efficiently extract a broad range of compounds, including glucosides.

- **Solvent Partitioning:** The crude extract would then be suspended in water and partitioned successively with solvents of increasing polarity, for example, n-hexane, chloroform, and ethyl acetate. This step aims to separate compounds based on their polarity, with benzophenone C-glucosides like **Glomeratide A** expected to concentrate in the more polar fractions (e.g., ethyl acetate or n-butanol).
- **Chromatographic Separation:** The enriched fraction would undergo a series of chromatographic techniques for further purification. This typically includes:
 - **Column Chromatography:** Initial separation on a silica gel or reversed-phase (C18) column using a gradient elution system.
 - **Preparative High-Performance Liquid Chromatography (HPLC):** Final purification of the isolated fractions to yield pure **Glomeratide A**.

The workflow for such an isolation process can be visualized as follows:

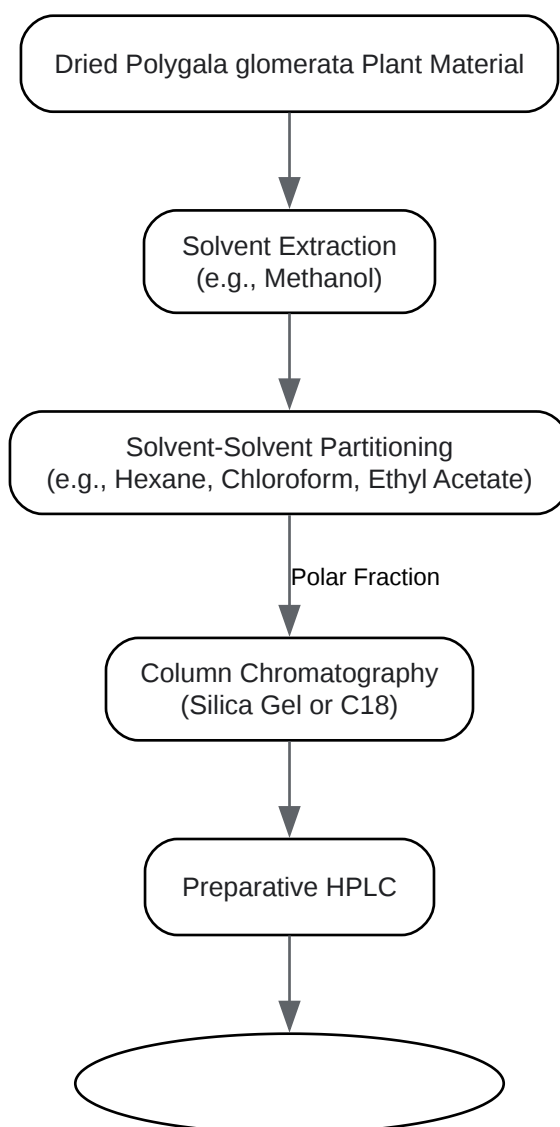

[Click to download full resolution via product page](#)

Figure 1: Generalized workflow for the isolation of **Glomeratide A**.

Spectroscopic Analysis for Structure Elucidation

The determination of the chemical structure of **Glomeratide A** would have relied on a combination of mass spectrometry and nuclear magnetic resonance spectroscopy.

Mass Spectrometry

High-Resolution Electrospray Ionization Mass Spectrometry (HR-ESI-MS) is a key technique for determining the molecular formula of a novel compound.

Illustrative Data for **Glomeratide A**

Ion	Calculated m/z	Measured m/z	Molecular Formula
[M+H] ⁺	Value	Value	C ₂₀ H ₂₂ O ₁₁
[M+Na] ⁺	Value	Value	C ₂₀ H ₂₁ NaO ₁₁
[M-H] ⁻	Value	Value	C ₂₀ H ₂₁ O ₁₀

Note: The exact m/z values are not available in the public domain and are represented here as placeholders.

The fragmentation pattern in tandem MS (MS/MS) experiments would provide further structural information, such as the loss of the glucose moiety.

Nuclear Magnetic Resonance (NMR) Spectroscopy

1D (¹H and ¹³C) and 2D (COSY, HSQC, HMBC) NMR experiments are crucial for piecing together the connectivity of atoms in the molecule.

¹H and ¹³C NMR Data (Illustrative)

The following table represents the type of data that would be generated for **Glomeratide A**, with chemical shifts (δ) reported in ppm and coupling constants (J) in Hz. The exact values are hypothetical.

Position	δC (ppm)	δH (ppm, mult., J in Hz)
Benzophenone Moiety		
2	~165.0	
3	~105.0	6.5 (d, 2.0)
4	~160.0	
5	~100.0	6.3 (d, 2.0)
6	~162.0	
1'	~130.0	
2'	~145.0	7.2 (d, 8.5)
3'	~115.0	6.9 (dd, 8.5, 2.5)
4'	~150.0	
5'	~118.0	7.1 (d, 2.5)
6'	~125.0	
C=O	~198.0	
C-Glucosyl Moiety		
1''	~75.0	4.8 (d, 9.5)
2''	~72.0	3.5 (m)
3''	~80.0	3.6 (m)
4''	~71.0	3.4 (m)
5''	~82.0	3.8 (m)
6''a	~63.0	3.9 (dd, 12.0, 2.0)
6''b	3.7 (dd, 12.0, 5.5)	

The logical connections derived from 2D NMR experiments are fundamental to assembling the final structure.

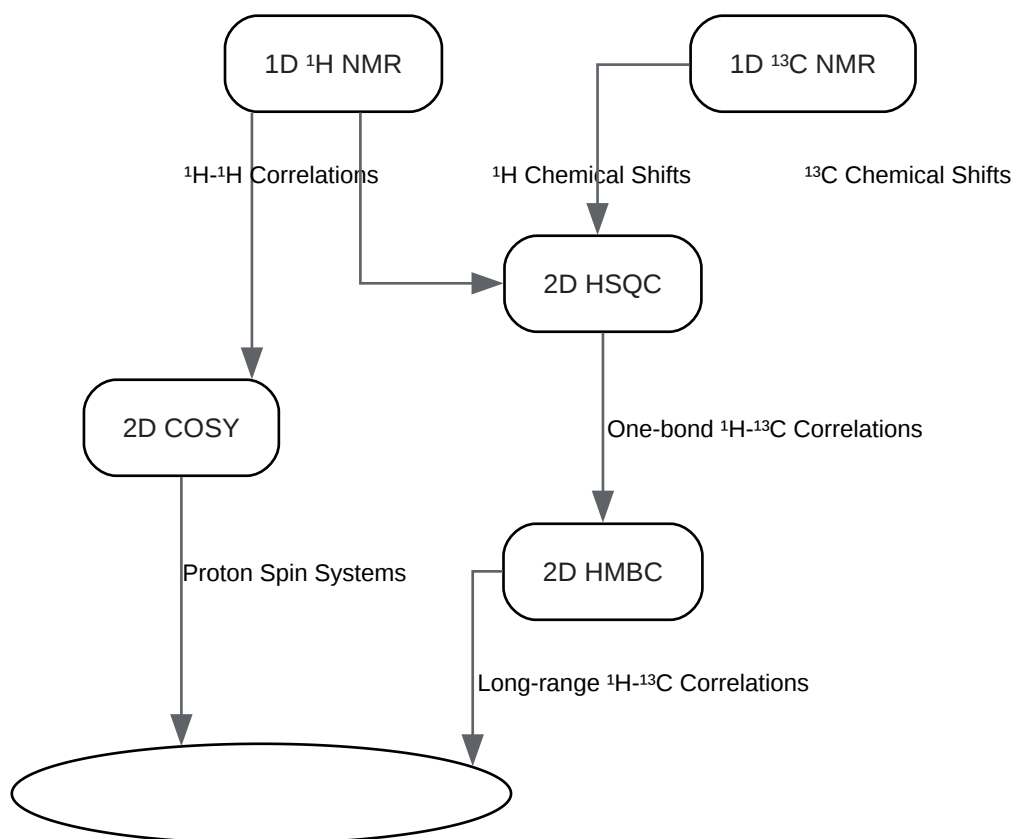

[Click to download full resolution via product page](#)

Figure 2: Logical relationships in NMR-based structure elucidation.

Concluding Remarks

The elucidation of the structure of **Glomeratide A** is a testament to the power of modern spectroscopic techniques in natural product chemistry. The combination of mass spectrometry and a suite of NMR experiments allows for the unambiguous determination of the molecular formula and the intricate connectivity of atoms within the molecule. Further research, including total synthesis, would be required to confirm the absolute stereochemistry of **Glomeratide A**. The hepatoprotective activities reported for **Glomeratide A** and related compounds from *Polygala glomerata* underscore the importance of such structural studies in the quest for new therapeutic agents.^[1]

Need Custom Synthesis?

BenchChem offers custom synthesis for rare earth carbides and specific isotopic labeling.

Email: info@benchchem.com or [Request Quote Online](#).

References

- 1. Benzophenone C-glucosides from Polygala glomerata Lour - PubMed [pubmed.ncbi.nlm.nih.gov]
- 2. researchgate.net [researchgate.net]
- To cite this document: BenchChem. [Unveiling the Molecular Architecture of Glomeratide A: A Technical Overview]. BenchChem, [2025]. [Online PDF]. Available at: [https://www.benchchem.com/product/b12385566#glomeratide-a-chemical-structure-elucidation]

Disclaimer & Data Validity:

The information provided in this document is for Research Use Only (RUO) and is strictly not intended for diagnostic or therapeutic procedures. While BenchChem strives to provide accurate protocols, we make no warranties, express or implied, regarding the fitness of this product for every specific experimental setup.

Technical Support: The protocols provided are for reference purposes. Unsure if this reagent suits your experiment? [[Contact our Ph.D. Support Team for a compatibility check](#)]

Need Industrial/Bulk Grade? [Request Custom Synthesis Quote](#)

BenchChem

Our mission is to be the trusted global source of essential and advanced chemicals, empowering scientists and researchers to drive progress in science and industry.

Contact

Address: 3281 E Guasti Rd

Ontario, CA 91761, United States

Phone: (601) 213-4426

Email: info@benchchem.com