

Unveiling the Electronic Landscape of Antimony Oxychloride: A Technical Guide

Author: BenchChem Technical Support Team. **Date:** December 2025

Compound of Interest

Compound Name: *Antimony oxychloride*

Cat. No.: *B147858*

[Get Quote](#)

For Immediate Release

Shanghai, China – December 17, 2025 – In a significant step forward for materials science, this technical guide provides an in-depth analysis of the electronic band structure of **antimony oxychloride** (SbOCl), a compound of increasing interest for its potential applications in photocatalysis, optoelectronics, and as a flame retardant. This document, tailored for researchers, scientists, and professionals in drug development, synthesizes crystallographic data, experimental protocols, and theoretical calculations to offer a comprehensive understanding of SbOCl's electronic properties.

Antimony oxychloride crystallizes in a monoclinic system with the space group $P2_1/c$.^[1] Unlike other layered **antimony oxychlorides**, SbOCl possesses a non-layered structure where chlorine atoms are covalently bonded to antimony.^[1] This unique structural arrangement significantly influences its electronic characteristics.

Crystallographic and Electronic Properties

Theoretical investigations into the electronic structure of SbOCl, primarily conducted using Density Functional Theory (DFT), reveal it to be a semiconductor with a direct band gap. The calculated band structure indicates that both the valence band maximum (VBM) and the conduction band minimum (CBM) are located at the same point in the Brillouin zone, a characteristic feature of direct band gap materials. The energy of this band gap is reported to be in the range of 2.7 to 3.5 eV.

Analysis of the partial density of states (PDOS) provides insight into the atomic orbital contributions to the electronic bands. The valence band is primarily composed of O 2p and Cl 3p orbitals, with some contribution from Sb 5p orbitals. The conduction band is largely dominated by the unoccupied Sb 5p orbitals. This understanding of the orbital contributions is crucial for designing materials with tailored electronic and optical properties.

Quantitative Data Summary

The following tables summarize the key crystallographic and computational parameters for **antimony oxychloride**.

Table 1: Crystallographic Data for **Antimony Oxychloride** (SbOCl)

Parameter	Value	Reference
Crystal System	Monoclinic	[1]
Space Group	P2 ₁ /c	[1]
a (Å)	7.908(9)	[1]
b (Å)	10.732(14)	[1]
c (Å)	9.527(10)	[1]
β (°)	103.65	[1]
Z (formula units/cell)	12	[1]

Table 2: Parameters for DFT-based Electronic Band Structure Calculations of SbOCl

Parameter	Specification	Reference
Software	CASTEP	[2]
Method	Plane-wave pseudopotential	[2]
Exchange-Correlation Functional	Generalized Gradient Approximation (GGA) with Perdew–Burke–Ernzerhof (PBE)	[2]

Experimental and Computational Workflows

The synthesis of high-quality SbOCl crystals is a prerequisite for both experimental characterization and accurate theoretical modeling. The following section details a typical hydrothermal synthesis protocol. Furthermore, a generalized workflow for the computational determination of the electronic band structure is presented.

Experimental Protocol: Hydrothermal Synthesis of SbOCl

A common method for the synthesis of **antimony oxychloride** is through the hydrolysis of antimony trichloride (SbCl_3).^[1] A specific protocol for producing single crystals involves a hydrothermal reaction.

Materials:

- Antimony trichloride (SbCl_3)
- Boric acid (H_3BO_3)
- Deionized water

Procedure:

- Dissolve SbCl_3 and H_3BO_3 in a 1:3 molar ratio in 2 mL of deionized water.^[2]
- Transfer the solution to a 23 mL Teflon-lined autoclave.^[2]
- Heat the autoclave to 220 °C at a rate of 10 °C/h.^[2]
- Maintain the temperature for a specified duration to allow for crystal growth.
- Cool the autoclave to room temperature.
- Separate the resulting transparent single crystals from the reaction mixture.^[2]

Visualizing Methodologies

To further elucidate the processes involved in the study of **antimony oxychloride**, the following diagrams illustrate the experimental and computational workflows.



[Click to download full resolution via product page](#)

A simplified workflow for the hydrothermal synthesis of SbOCl crystals.

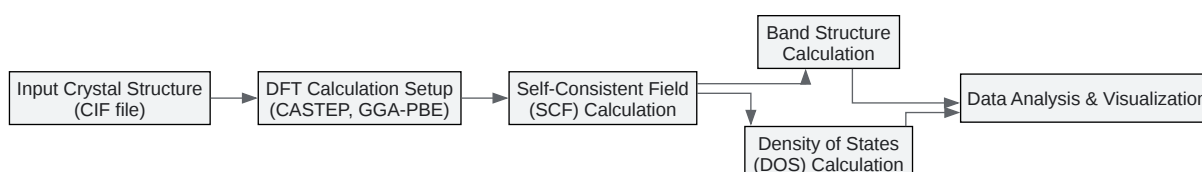

[Click to download full resolution via product page](#)

A typical workflow for DFT-based electronic band structure calculations.

Signaling Pathways and Logical Relationships

The relationship between the atomic structure and the resulting electronic properties of SbOCl can be visualized as a logical flow. The specific arrangement of atoms and their bonding characteristics directly determine the electronic band structure and density of states.

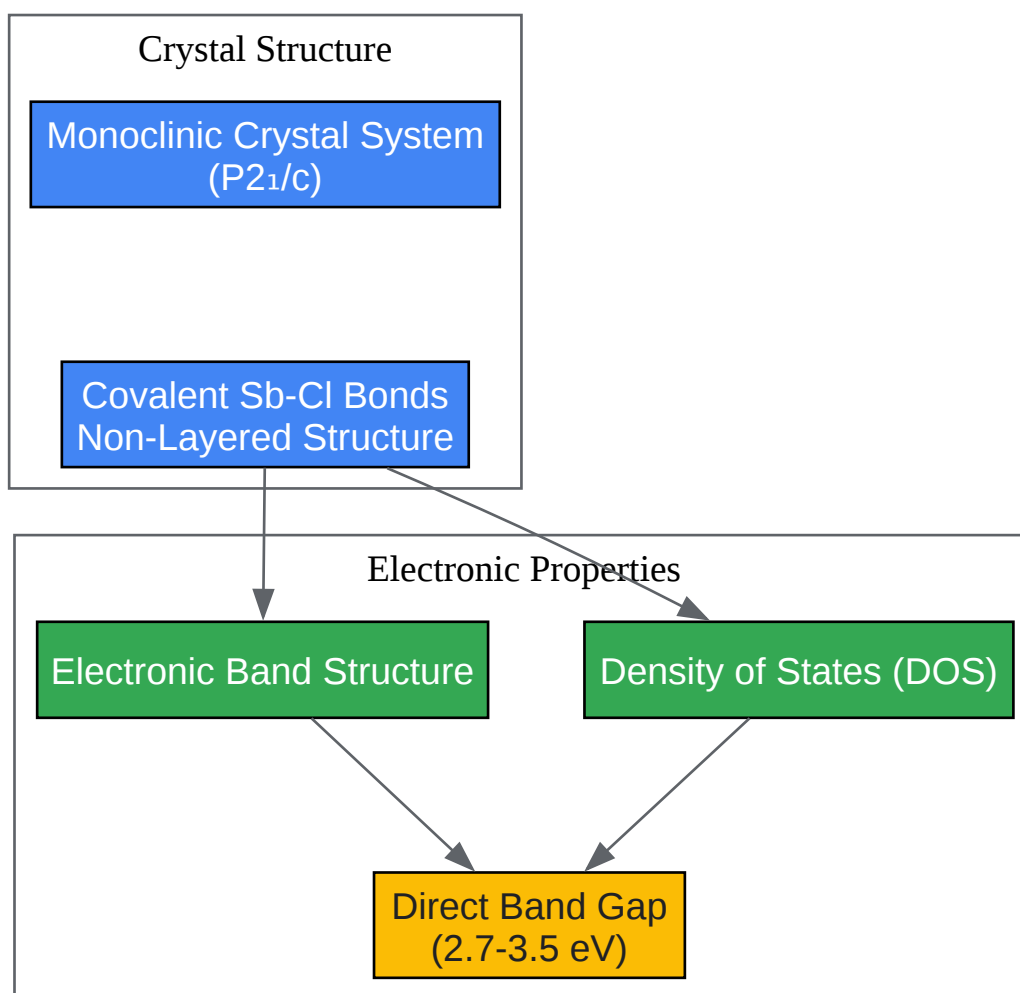

[Click to download full resolution via product page](#)

The relationship between the crystal structure and electronic properties of SbOCl.

This comprehensive guide provides a foundational understanding of the electronic band structure of **antimony oxychloride**, paving the way for further research and application development in various scientific and technological fields. The detailed methodologies and summarized data offer a valuable resource for professionals seeking to explore the potential of this promising material.

Need Custom Synthesis?

BenchChem offers custom synthesis for rare earth carbides and specific isotopic labeling.

Email: info@benchchem.com or [Request Quote Online](#).

References

- 1. mdpi.com [mdpi.com]
- 2. rsc.org [rsc.org]
- To cite this document: BenchChem. [Unveiling the Electronic Landscape of Antimony Oxychloride: A Technical Guide]. BenchChem, [2025]. [Online PDF]. Available at: [https://www.benchchem.com/product/b147858#electronic-band-structure-calculations-for-antimony-oxychloride]

Disclaimer & Data Validity:

The information provided in this document is for Research Use Only (RUO) and is strictly not intended for diagnostic or therapeutic procedures. While BenchChem strives to provide accurate protocols, we make no warranties, express or implied, regarding the fitness of this product for every specific experimental setup.

Technical Support: The protocols provided are for reference purposes. Unsure if this reagent suits your experiment? [[Contact our Ph.D. Support Team for a compatibility check](#)]

Need Industrial/Bulk Grade? [Request Custom Synthesis Quote](#)

BenchChem

Our mission is to be the trusted global source of essential and advanced chemicals, empowering scientists and researchers to drive progress in science and industry.

Contact

Address: 3281 E Guasti Rd
Ontario, CA 91761, United States
Phone: (601) 213-4426
Email: info@benchchem.com