

# Unveiling the Antibacterial Arsenal: A Comparative Analysis of Nidulin and Other Depsidones

**Author:** BenchChem Technical Support Team. **Date:** December 2025

## Compound of Interest

Compound Name: *Nidulin*

Cat. No.: *B609578*

[Get Quote](#)

For Immediate Release

[City, State] – [Date] – A comprehensive comparative guide offering an in-depth analysis of the antibacterial spectrum of the depsidone **nidulin** against other notable members of its class, including lobaric acid, salazinic acid, stictic acid, and fumarprotocetraric acid, has been published today. This guide, tailored for researchers, scientists, and drug development professionals, provides a meticulous examination of the available experimental data on the antibacterial efficacy of these natural compounds.

Depsidones, a class of polyphenolic compounds produced by lichens and fungi, have long been recognized for their diverse biological activities. Among these, their antibacterial properties have garnered significant interest in the scientific community, offering potential avenues for the development of new antimicrobial agents. This guide aims to consolidate and clarify the current understanding of the antibacterial profiles of selected prominent depsidones.

## Comparative Antibacterial Spectrum

The antibacterial efficacy of these depsidones is predominantly evaluated by their Minimum Inhibitory Concentration (MIC), the lowest concentration of a substance that prevents visible growth of a microorganism. The data presented below, collated from various scientific studies, highlights the differential activity of these compounds against a panel of clinically relevant bacteria.

Depsidone	Staphylococcus aureus (MRSA) (µg/mL)	Staphylococcus aureus (µg/mL)	Escherichia coli (µg/mL)	Pseudomonas aeruginosa (µg/mL)	Enterococcus faecalis (µg/mL)
Nidulin	0.25–1[1]	0.5[1]	>128	>128	>128
Lobaric Acid	-	-	Potent activity	-	-
Salazinic Acid	-	125[1]	1000[1]	>1000	-
Stictic Acid	-	250-500[2]	>500	250-500	-
Fumarprotocetraric Acid	-	-	-	-	-

Note: A hyphen (-) indicates that no specific data was found for this compound against the listed bacterium in the reviewed literature.

The data indicates that **nidulin** and its derivatives exhibit potent activity, particularly against Gram-positive bacteria, including Methicillin-resistant Staphylococcus aureus (MRSA)[1][3]. Some semisynthetic derivatives of **nidulin** have shown even more potent antibacterial activities than the parent compound[3]. In contrast, many lichen-derived depsidones, such as salazinic acid and stictic acid, tend to show moderate to weak activity and often have a narrower spectrum, being more effective against Gram-positive than Gram-negative bacteria[1][2]. For instance, salazinic acid shows some activity against S. aureus but is largely ineffective against E. coli[1].

## Experimental Protocols

The determination of the Minimum Inhibitory Concentration (MIC) is a cornerstone of assessing antibacterial activity. The data presented in this guide is primarily derived from studies employing the broth microdilution method, a standardized and widely accepted technique.

## General Broth Microdilution Protocol (as per CLSI Guidelines)

This protocol outlines the general steps for determining the MIC of a compound against a bacterial strain.

### 1. Preparation of Materials:

- **Test Compound:** The depsidone is dissolved in a suitable solvent, typically dimethyl sulfoxide (DMSO), to create a stock solution.
- **Bacterial Culture:** A pure culture of the test bacterium is grown overnight on an appropriate agar medium. Several colonies are then used to inoculate a sterile broth (e.g., Mueller-Hinton Broth - MHB), and the suspension is adjusted to a turbidity equivalent to a 0.5 McFarland standard. This standardized suspension is then further diluted to achieve the desired final inoculum concentration in the assay.
- **Microtiter Plate:** A sterile 96-well microtiter plate is used to perform the serial dilutions.

### 2. Assay Procedure:

- **Serial Dilution:** The depsidone stock solution is serially diluted in the wells of the microtiter plate containing fresh broth to create a range of concentrations.
- **Inoculation:** Each well is inoculated with the prepared bacterial suspension.
- **Controls:**
  - **Positive Control:** A well containing broth and the bacterial inoculum without any test compound to ensure bacterial growth.
  - **Negative Control:** A well containing only broth to check for contamination.
  - **Solvent Control:** A well containing the highest concentration of the solvent (e.g., DMSO) used to dissolve the depsidone to ensure it does not inhibit bacterial growth on its own.
- **Incubation:** The plate is incubated under appropriate conditions (e.g., 37°C for 18-24 hours).

### 3. Determination of MIC:

- The MIC is determined as the lowest concentration of the depsidone at which there is no visible growth of the bacteria. This can be assessed visually or by using a growth indicator dye like resazurin.

## Visualization of Experimental Workflow

To provide a clearer understanding of the experimental process, the following diagram illustrates the typical workflow for determining the Minimum Inhibitory Concentration (MIC) using the broth microdilution method.

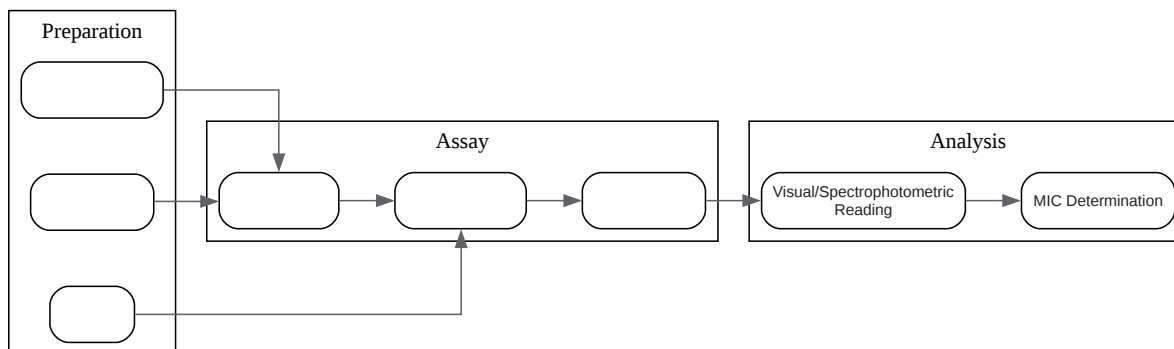

[Click to download full resolution via product page](#)

**Caption:** Workflow for MIC determination by broth microdilution.

## Putative Antibacterial Mechanisms

The precise antibacterial mechanisms of many depsidones are still under investigation. However, a recurring theme in the literature is their ability to disrupt bacterial cell membranes. This disruption can lead to a cascade of detrimental effects, ultimately resulting in bacterial cell death.

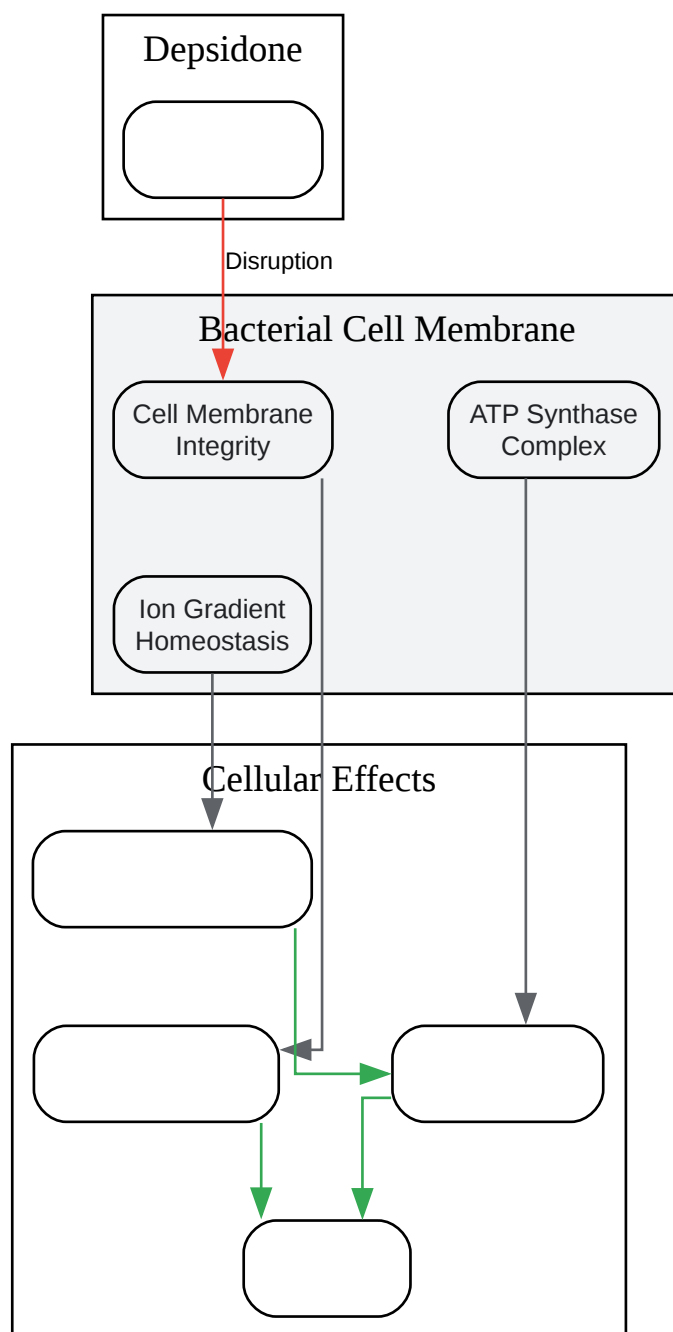

[Click to download full resolution via product page](#)

**Caption:** Putative mechanism of antibacterial action for depsidones.

The lipophilic nature of depsidones is thought to facilitate their interaction with and insertion into the bacterial cell membrane. This can lead to a loss of membrane integrity, causing the leakage of essential intracellular components such as ions, metabolites, and nucleic acids. Furthermore, the disruption of the membrane can dissipate the proton motive force, which is

crucial for ATP synthesis, leading to a severe energy deficit within the bacterial cell. While this general mechanism is widely proposed, the specific molecular targets and signaling pathways affected by individual depsidones, such as **nidulin**, lobaric acid, and others, remain an active area of research. For example, some studies suggest that certain depsidones may also interfere with bacterial signaling pathways or inhibit essential enzymes, but more definitive evidence is needed[4][5].

This comparative guide underscores the potential of depsidones as a source of new antibacterial compounds. Further research is warranted to fully elucidate their mechanisms of action and to explore their therapeutic potential in combating bacterial infections.

#### Need Custom Synthesis?

BenchChem offers custom synthesis for rare earth carbides and specific isotopic labeling.

Email: [info@benchchem.com](mailto:info@benchchem.com) or [Request Quote Online](#).

## References

- 1. researchgate.net [researchgate.net]
- 2. Stictic acid | 549-06-4 | Benchchem [benchchem.com]
- 3. Semisynthesis and antibacterial activities of nidulin derivatives - PubMed [pubmed.ncbi.nlm.nih.gov]
- 4. Anti-Inflammatory Activity of Lobaric Acid via Suppressing NF- $\kappa$ B/MAPK Pathways or NLRP3 Inflammasome Activation - PubMed [pubmed.ncbi.nlm.nih.gov]
- 5. biolichen.com [biolichen.com]
- To cite this document: BenchChem. [Unveiling the Antibacterial Arsenal: A Comparative Analysis of Nidulin and Other Depsidones]. BenchChem, [2025]. [Online PDF]. Available at: [https://www.benchchem.com/product/b609578#comparing-antibacterial-spectrum-of-nidulin-to-other-depsidones]

---

#### Disclaimer & Data Validity:

The information provided in this document is for Research Use Only (RUO) and is strictly not intended for diagnostic or therapeutic procedures. While BenchChem strives to provide

accurate protocols, we make no warranties, express or implied, regarding the fitness of this product for every specific experimental setup.

**Technical Support:** The protocols provided are for reference purposes. Unsure if this reagent suits your experiment? [[Contact our Ph.D. Support Team for a compatibility check](#)]

**Need Industrial/Bulk Grade?** [Request Custom Synthesis Quote](#)

## BenchChem

Our mission is to be the trusted global source of essential and advanced chemicals, empowering scientists and researchers to drive progress in science and industry.

### Contact

Address: 3281 E Guasti Rd

Ontario, CA 91761, United States

Phone: (601) 213-4426

Email: [info@benchchem.com](mailto:info@benchchem.com)