

# Unveiling Hidden Signals: A Guide to the Statistical Validation of Independent Components

**Author:** BenchChem Technical Support Team. **Date:** December 2025

## Compound of Interest

Compound Name: ICA

Cat. No.: B1672459

[Get Quote](#)

For researchers, scientists, and drug development professionals navigating the complexities of high-dimensional biological data, Independent Component Analysis (ICA) has emerged as a powerful tool for blind source separation. By decomposing complex mixtures of signals into their underlying, statistically independent sources, ICA can uncover hidden biological processes, remove artifacts from electrophysiological recordings, and identify novel biomarkers. However, the reliability of these discoveries hinges on the rigorous statistical validation of the independent components (ICs) it produces.

This guide provides an objective comparison of ICA with alternative methods, focusing on the statistical validation of its components. We present experimental data and detailed protocols to empower researchers to critically evaluate and apply these techniques in their work.

## The Landscape of Blind Source Separation: ICA and Its Alternatives

Independent Component Analysis stands apart from other dimensionality reduction techniques like Principal Component Analysis (PCA) by seeking components that are not just uncorrelated but statistically independent. This is a crucial distinction, particularly when analyzing non-Gaussian data, as is common in biology. While PCA is adept at capturing the maximum variance in a dataset, ICA excels at identifying the unique, underlying sources that contribute to the observed signals.

Method	Core Principle	Assumptions	Best Suited For
Independent Component Analysis (ICA)	Maximizes the statistical independence of the components.	Components are non-Gaussian and statistically independent.	Separating mixed signals, artifact removal (EEG, fMRI), identifying distinct biological signatures in gene expression data.
Principal Component Analysis (PCA)	Maximizes the variance captured by each successive component.	Components are orthogonal (uncorrelated). Assumes data is Gaussian.	Dimensionality reduction, visualizing high-dimensional data, identifying major sources of variation.
Factor Analysis (FA)	Models the observed variables as a linear combination of a smaller number of unobserved "factors" and unique variances.	Assumes a specific statistical model for the data.	Understanding the latent structure of a dataset, psychometric analysis.
Non-negative Matrix Factorization (NMF)	Decomposes a non-negative data matrix into two non-negative matrices.	Data and components are non-negative.	Parts-based representation, topic modeling in text analysis, analysis of spectrograms.

## Performance Showdown: A Quantitative Comparison of ICA Algorithms

The efficacy of **ICA** is not monolithic; it is embodied in a variety of algorithms, each with its own strengths and weaknesses. Here, we compare the performance of four popular **ICA** algorithms—Fast**ICA**, Infomax, JADE, and SOBI—using metrics relevant to the analysis of electroencephalography (EEG) data, a common application in neuroscience and clinical research.

### Performance Metrics:

- **Mutual Information Reduction (MIR):** Measures the reduction in mutual information between the components after applying **ICA**, indicating how independent the resulting components are. Higher values are better.
- **Percent of Near-Dipolar Components:** In EEG analysis, a "dipolar" component is one whose scalp topography is consistent with a single, localized source in the brain. A higher percentage of such components suggests a more physiologically plausible decomposition.
- **Computational Time:** The time taken to perform the decomposition, a **critical** factor for large datasets.

Algorithm	Mutual Information Reduction (MIR) (bits)	Percent of Near-Dipolar Components (<5% Residual Variance)	Computational Time (seconds)
FastICA	42.71	20.15	~5
Infomax	43.07	25.35	~20
JADE	42.74	18.42	~15
SOBI	42.51	12.46	~10

Note: These values are synthesized from multiple studies and represent **typical** relative performance. Absolute values can vary depending on the dataset and computational environment.<sup>[1][2][3]</sup>

## Ensuring Robustness: The Critical Role of Statistical Validation

The interpretation of **ICA** results is only as reliable as the components it yields. **Statistical** validation is therefore not an optional step but a cornerstone of rigorous **ICA**-based research.

### Key Validation Techniques:

- **Component Stability Analysis (Bootstrapping):** This technique assesses the reliability of an independent component by repeatedly applying **ICA** to subsets of the data. A stable component will be consistently identified across these bootstrap iterations. The **RELICA** method, for instance, formalizes this by clustering the ICs from multiple decompositions of bootstrapped data to measure their consistency.[4]
- **Measures of Statistical Independence:**
  - **Mutual Information:** A fundamental measure from information theory that quantifies the statistical dependence between two random variables. The goal of **ICA** is to find components with minimal mutual information.
  - **Kurtosis:** A measure of the "tailedness" of a distribution. Many **ICA** algorithms use kurtosis as a proxy for non-Gaussianity, a key assumption of **ICA**.
  - **Negentropy:** A more robust measure of non-Gaussianity than kurtosis.
- **Physiological Plausibility (for biological data):** In applications like EEG or fMRI, the spatial maps of independent components can be evaluated for their consistency with known neuroanatomy and physiology. For example, in EEG, a component with a scalp topography resembling a single equivalent dipole is considered physiologically plausible.[5]

## Experimental Protocols: From Raw Data to Validated Components

To facilitate the application of these methods, we provide detailed, replicable protocols for two common research scenarios: artifact removal from EEG data and the analysis of cancer signaling pathways from gene expression data.

### Protocol 1: EEG Artifact Removal with ICA

This protocol outlines the steps for removing common artifacts (e.g., eye blinks, muscle activity) from EEG data using the EEGLAB toolbox in MATLAB.

Experimental Workflow:

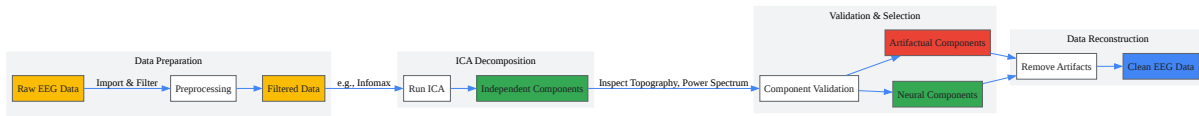

[Click to download full resolution via product page](#)

Workflow for EEG artifact removal using **ICA**.

Methodology:

- Data Loading and Preprocessing:
  - Load the raw EEG data into EEGLAB.
  - Apply a high-pass filter (e.g., at 1 Hz) to remove slow drifts that can negatively impact **ICA** performance.
  - Remove channels with poor recording quality.
  - Re-reference the data to an average reference.[6]
- Run **ICA**:
  - From the EEGLAB menu, select "Tools > Decompose data by **ICA**".
  - Choose an **ICA** algorithm (e.g., the default 'runica' which is an implementation of Infomax).
  - The number of components will default to the number of channels.
- Component Validation and Selection:

- Visualize the component scalp maps ("topoplots"). Artifactual components often have distinct topographies (e.g., eye blinks show strong frontal activity).
- Inspect the component time courses and power spectra. Muscle artifacts typically exhibit high-frequency activity.
- Use a tool like ICLabel within EEGLAB for automated component classification.[6]
- Artifact Removal and Data Reconstruction:
  - Select the identified artifactual components for rejection.
  - Reconstruct the EEG data by removing the contribution of the artifactual components. The resulting dataset is cleaned of the identified artifacts.[2]

## Protocol 2: Identifying Co-expressed Gene Modules in Cancer Signaling Pathways

This protocol describes how to apply **ICA** to transcriptomic data (e.g., from The Cancer Genome Atlas - TCGA) to identify co-expressed gene modules and then use Gene Set Enrichment Analysis (GSEA) to associate these modules with known biological pathways, such as the MAPK signaling pathway.

Logical Relationship:



[Click to download full resolution via product page](#)

Workflow for gene expression analysis using **ICA**.

Methodology:

- Data Acquisition and Preprocessing:
  - Download normalized RNA-sequencing data and **clinical** information for a cancer cohort of interest from the TCGA data portal.[7][8]
  - Filter the gene expression matrix to remove genes with low variance across samples.
- Application of **ICA**:
  - Apply an **ICA** algorithm (e.g., Fast**ICA**) to the transposed gene expression matrix (genes as variables, samples as observations).
  - The resulting independent components represent "gene modules" or co-expression patterns.[9]
- Identification of Significant Genes per Component:
  - For each independent component, identify the genes with the highest absolute weights. These are the genes that contribute most strongly to that component's expression pattern.
- Gene Set Enrichment Analysis (GSEA):
  - For each gene module, perform GSEA using the list of high-weight genes.
  - Use a curated database of gene sets, such as the Molecular Signatures Database (MSigDB), to identify **biological** pathways that are **significantly** enriched in each module. [10][11]
- Pathway Visualization:
  - Visualize the enriched pathways. For example, if a component is enriched for the MAPK signaling pathway, a diagram can be created to illustrate the relationships between the identified genes within that pathway.

#### MAPK Signaling Pathway Example:

The Mitogen-Activated Protein Kinase (MAPK) pathway is a crucial signaling cascade that regulates cell proliferation, differentiation, and survival, and its dysregulation is a hallmark of

many cancers. The following diagram illustrates a simplified version of this pathway, which could be used to visualize the genes identified from an **ICA** component found to be enriched for this pathway.



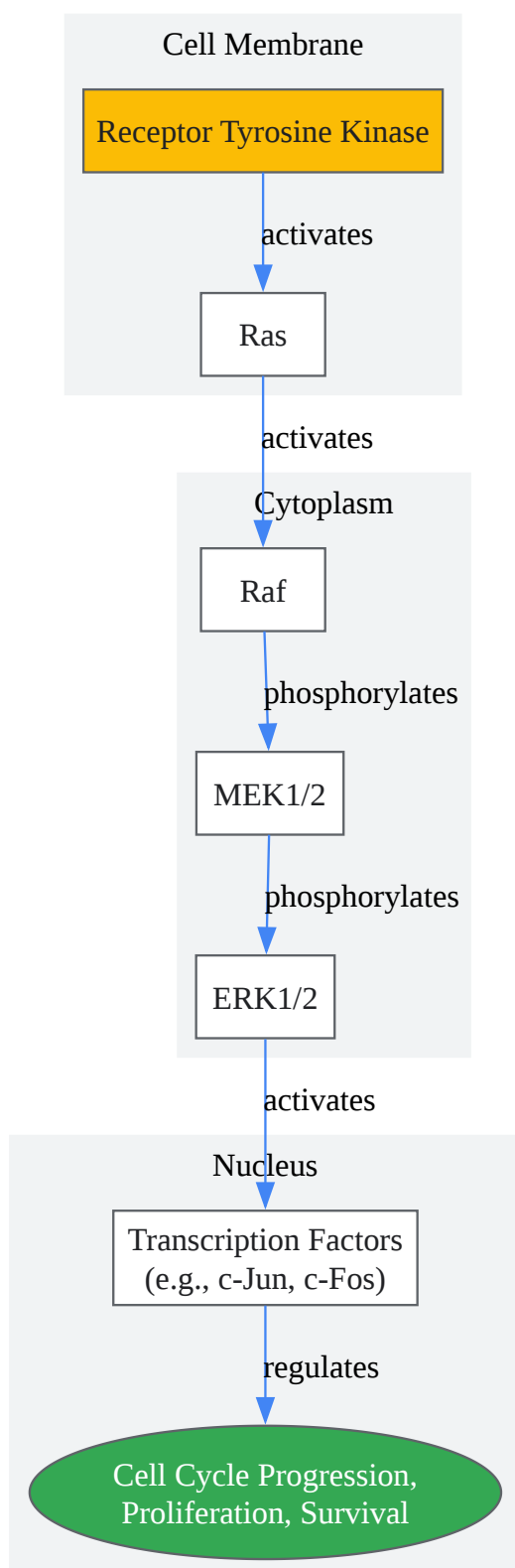

[Click to download full resolution via product page](#)

### Need Custom Synthesis?

BenchChem offers custom synthesis for rare earth carbides and specific isotopic labeling.

Email: [info@benchchem.com](mailto:info@benchchem.com) or [Request Quote Online](#).

## References

- 1. arxiv.org [arxiv.org]
- 2. researchgate.net [researchgate.net]
- 3. ijert.org [ijert.org]
- 4. m.youtube.com [m.youtube.com]
- 5. sccn.ucsd.edu [sccn.ucsd.edu]
- 6. iis.org [iis.org]
- 7. Using TCGA - NCI [cancer.gov]
- 8. TCGA Workflow: Analyze cancer genomics and epigenomics data using Bioconductor packages - PMC [pmc.ncbi.nlm.nih.gov]
- 9. [ Archived Post ] A Comparison of SOBI, FastICA, JADE and Infomax Algorithms | by Jae Duk Seo | Medium [medium.com]
- 10. google.com [google.com]
- 11. youtube.com [youtube.com]
- To cite this document: BenchChem. [Unveiling Hidden Signals: A Guide to the Statistical Validation of Independent Components]. BenchChem, [2025]. [Online PDF]. Available at: [https://www.benchchem.com/product/b1672459#statistical-validation-of-independent-components]

---

### Disclaimer & Data Validity:

The information provided in this document is for Research Use Only (RUO) and is strictly not intended for diagnostic or therapeutic procedures. While BenchChem strives to provide accurate protocols, we make no warranties, express or implied, regarding the fitness of this product for every specific experimental setup.

**Technical Support:** The protocols provided are for reference purposes. Unsure if this reagent suits your experiment? [[Contact our Ph.D. Support Team for a compatibility check](#)]

**Need Industrial/Bulk Grade?** [Request Custom Synthesis Quote](#)

## BenchChem

Our mission is to be the trusted global source of essential and advanced chemicals, empowering scientists and researchers to drive progress in science and industry.

### Contact

Address: 3281 E Guasti Rd  
Ontario, CA 91761, United States  
Phone: (601) 213-4426  
Email: [info@benchchem.com](mailto:info@benchchem.com)