

Understanding the Molecular Targets of Tosufloxacin: An In-depth Technical Guide

Author: BenchChem Technical Support Team. **Date:** December 2025

Compound of Interest

Compound Name: *Tosufloxacin*

Cat. No.: *B15565612*

[Get Quote](#)

For Researchers, Scientists, and Drug Development Professionals

Introduction

Tosufloxacin is a broad-spectrum fluoroquinolone antibiotic effective against a wide range of Gram-positive and Gram-negative bacteria. Its clinical efficacy is rooted in its ability to disrupt essential bacterial DNA replication and repair processes. This technical guide provides a comprehensive overview of the molecular targets of **Tosufloxacin**, detailing its mechanism of action, quantitative inhibitory data, relevant experimental protocols, and potential off-target effects.

Primary Molecular Targets: DNA Gyrase and Topoisomerase IV

The primary molecular targets of **Tosufloxacin** are two essential bacterial type II topoisomerase enzymes: DNA gyrase and topoisomerase IV.[1][2] These enzymes are crucial for managing DNA topology during replication, transcription, and repair.[3]

- DNA Gyrase: This enzyme introduces negative supercoils into the bacterial DNA, a process necessary to relieve the torsional stress that accumulates ahead of the replication fork.[2] Inhibition of DNA gyrase prevents DNA unwinding, thereby halting replication.
- Topoisomerase IV: This enzyme is primarily involved in the decatenation (unlinking) of newly replicated daughter chromosomes.[3] Inhibition of topoisomerase IV results in intertwined

chromosomes that cannot be segregated into daughter cells, leading to cell division failure.

[3]

Tosufloxacin, like other fluoroquinolones, exerts its bactericidal effect by stabilizing the transient covalent complexes formed between these enzymes and the bacterial DNA.[2] This stabilization of the "cleavable complex" leads to the accumulation of double-strand DNA breaks, which, if not repaired, are lethal to the bacterium.[2]

Quantitative Data: Inhibitory Activity of Tosufloxacin

The inhibitory potency of **Tosufloxacin** against its primary targets has been quantified using in vitro enzyme assays. The 50% inhibitory concentration (IC50) is a key metric for assessing this activity.

Target Enzyme	Bacterial Species	IC50 (µg/mL)	Reference
DNA Gyrase	Enterococcus faecalis	11.6	[1]
Topoisomerase IV	Enterococcus faecalis	3.89	[1]

Note: While specific IC50 values for **Tosufloxacin** against DNA gyrase and topoisomerase IV in other key pathogens like *Streptococcus pneumoniae* and *Staphylococcus aureus* were not available in the cited literature, comparative studies indicate that the activity of fluoroquinolones can vary between bacterial species and that the primary target (either DNA gyrase or topoisomerase IV) can also differ.[4][5][6]

Signaling Pathway: Inhibition of DNA Replication and Induction of the SOS Response

The interaction of **Tosufloxacin** with its molecular targets triggers a cascade of cellular events, culminating in bacterial cell death. A critical component of this response is the induction of the bacterial SOS system, a global response to DNA damage.

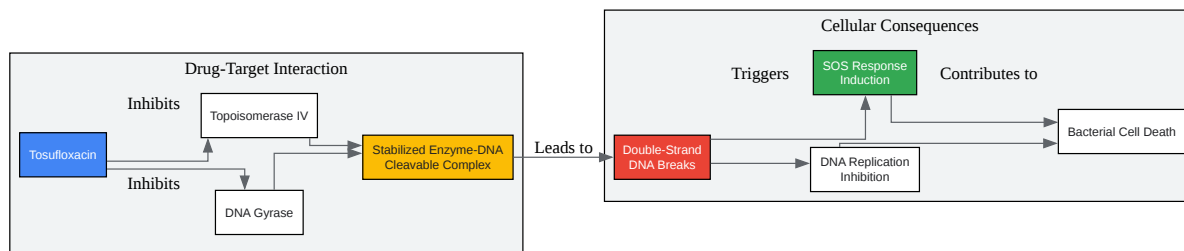

[Click to download full resolution via product page](#)

Mechanism of **Tosufloxacin** action and induction of the SOS response.

Experimental Protocols

DNA Gyrase Supercoiling Inhibition Assay

This assay measures the ability of a compound to inhibit the supercoiling of relaxed plasmid DNA by DNA gyrase.

Workflow:

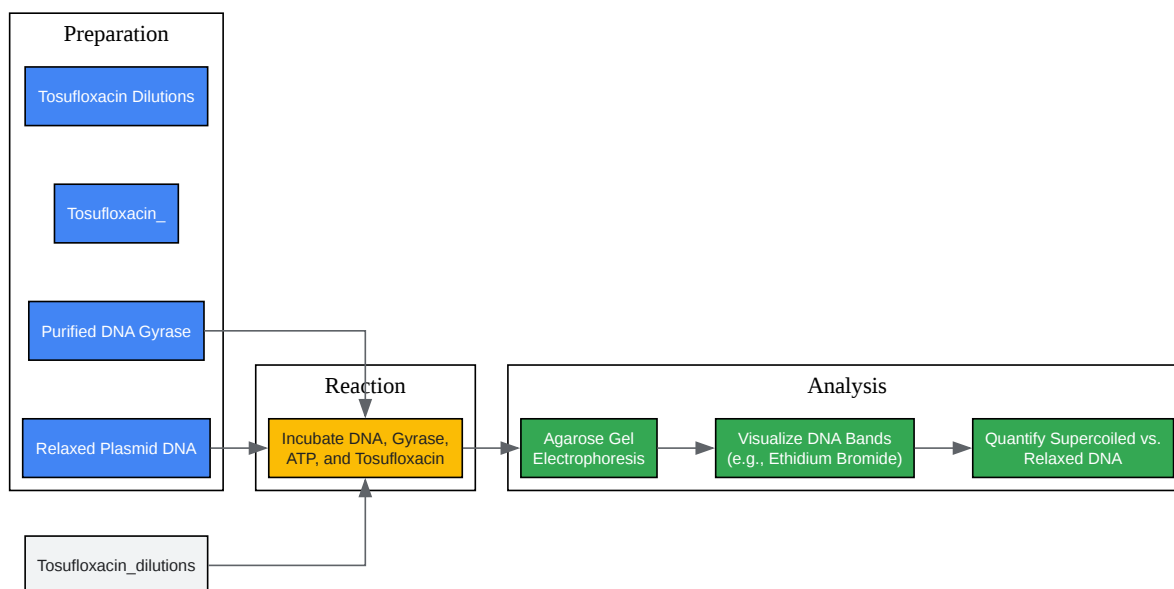

[Click to download full resolution via product page](#)

Workflow for a DNA gyrase supercoiling inhibition assay.

Detailed Methodology:

- **Reaction Mixture Preparation:** A typical reaction mixture contains a buffer (e.g., Tris-HCl), salts (e.g., KCl, MgCl₂), ATP, DTT, and relaxed plasmid DNA (e.g., pBR322).
- **Compound Addition:** Serial dilutions of **Tosufloxacin** (or other test compounds) are added to the reaction mixtures. A control reaction without the inhibitor is also prepared.
- **Enzyme Addition:** Purified DNA gyrase is added to initiate the reaction.
- **Incubation:** The reaction is incubated at an optimal temperature (e.g., 37°C) for a specific duration (e.g., 30-60 minutes) to allow for supercoiling to occur.

- **Reaction Termination:** The reaction is stopped by the addition of a stop solution containing a chelating agent (e.g., EDTA) and a loading dye.
- **Agarose Gel Electrophoresis:** The reaction products are separated on an agarose gel. Supercoiled DNA migrates faster than relaxed DNA.
- **Visualization and Quantification:** The DNA bands are visualized under UV light after staining with an intercalating dye (e.g., ethidium bromide). The intensity of the supercoiled and relaxed DNA bands is quantified to determine the percentage of inhibition at each drug concentration. The IC₅₀ value is then calculated.

Topoisomerase IV Decatenation Inhibition Assay

This assay assesses the ability of a compound to inhibit the decatenation of catenated kinetoplast DNA (kDNA) by topoisomerase IV.

Workflow:

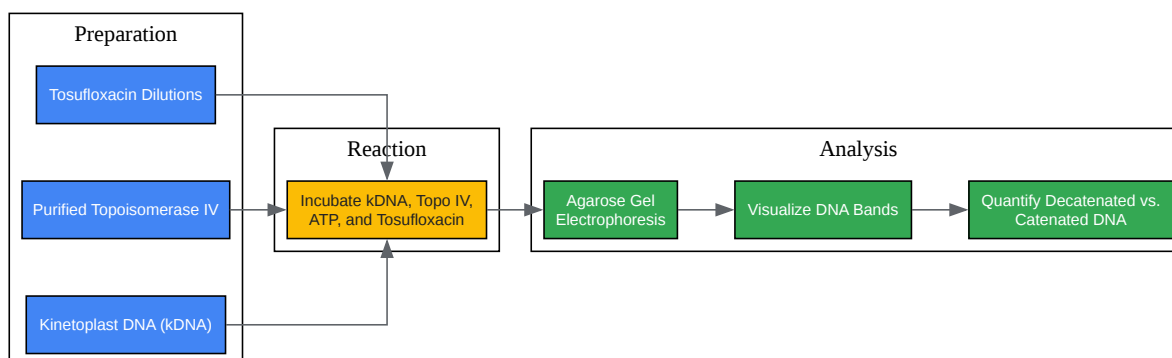

[Click to download full resolution via product page](#)

Workflow for a topoisomerase IV decatenation inhibition assay.

Detailed Methodology:

- **Reaction Mixture Preparation:** A reaction buffer containing Tris-HCl, potassium glutamate, MgCl₂, DTT, ATP, and kDNA is prepared.
- **Compound Addition:** Various concentrations of **Tosufloxacin** are added to the reaction tubes.
- **Enzyme Addition:** Purified topoisomerase IV is added to start the decatenation reaction.
- **Incubation:** The mixture is incubated at 37°C for approximately 30 minutes.
- **Reaction Termination:** The reaction is stopped, often by the addition of a solution containing SDS and EDTA.
- **Agarose Gel Electrophoresis:** The samples are run on an agarose gel. Decatenated minicircles migrate into the gel, while the large catenated kDNA network remains in the well.
- **Visualization and Quantification:** The gel is stained with a DNA-intercalating dye and visualized. The amount of released minicircles is quantified to determine the level of inhibition. The IC₅₀ is calculated from the dose-response curve.[1]

Secondary and Off-Target Effects

While highly selective for bacterial topoisomerases, fluoroquinolones, as a class, have been associated with some off-target effects, primarily related to mitochondrial toxicity.[7][8]

Mitochondrial Toxicity

Mitochondria, the powerhouses of eukaryotic cells, share evolutionary origins with bacteria. This similarity makes them potential unintended targets for some antibiotics. Studies on fluoroquinolones like ciprofloxacin have shown that at clinically relevant concentrations, they can induce mitochondrial dysfunction.[7][9][10] This dysfunction can manifest as:

- Increased production of reactive oxygen species (ROS)[7]
- Disruption of the electron transport chain[7]
- Decreased mitochondrial membrane potential[7]

- Reduced ATP production[7]

These effects can lead to oxidative stress and damage to cellular components, including DNA, proteins, and lipids.[7] While specific studies on **Tosufloxacin**'s direct impact on mitochondrial respiration are limited, the potential for class-wide effects should be considered in drug development and safety profiling.

Logical Relationship of Fluoroquinolone-Induced Mitochondrial Dysfunction:



[Click to download full resolution via product page](#)

Potential mechanism of fluoroquinolone-induced mitochondrial toxicity.

Conclusion

Tosufloxacin's potent antibacterial activity is primarily due to its dual inhibition of bacterial DNA gyrase and topoisomerase IV. This mechanism, leading to DNA damage and the induction of the SOS response, is well-established. Quantitative analysis of its inhibitory effects provides a clear measure of its potency. The detailed experimental protocols outlined in this guide serve as a foundation for further research and development of novel fluoroquinolone derivatives. While effective, the potential for off-target mitochondrial effects, a characteristic of the fluoroquinolone class, warrants consideration in preclinical and clinical safety assessments. A thorough understanding of these molecular interactions is paramount for the rational design of new antibacterial agents and for optimizing the clinical use of existing drugs like **Tosufloxacin**.

Need Custom Synthesis?

BenchChem offers custom synthesis for rare earth carbides and specific isotopic labeling.

Email: info@benchchem.com or [Request Quote Online](#).

References

- 1. Inhibitory Activities of Quinolones against DNA Gyrase and Topoisomerase IV of *Enterococcus faecalis* - PMC [pmc.ncbi.nlm.nih.gov]
- 2. Topoisomerase Inhibitors: Fluoroquinolone Mechanisms of Action and Resistance - PMC [pmc.ncbi.nlm.nih.gov]
- 3. The effect of moxifloxacin on its target topoisomerases from *Escherichia coli* and *Staphylococcus aureus* - PubMed [pubmed.ncbi.nlm.nih.gov]
- 4. Target Preference of 15 Quinolones against *Staphylococcus aureus*, Based on Antibacterial Activities and Target Inhibition - PMC [pmc.ncbi.nlm.nih.gov]
- 5. *Streptococcus pneumoniae* DNA Gyrase and Topoisomerase IV: Overexpression, Purification, and Differential Inhibition by Fluoroquinolones - PMC [pmc.ncbi.nlm.nih.gov]
- 6. Contribution of topoisomerase IV and DNA gyrase mutations in *Streptococcus pneumoniae* to resistance to novel fluoroquinolones - PubMed [pubmed.ncbi.nlm.nih.gov]
- 7. Bactericidal Antibiotics Induce Mitochondrial Dysfunction and Oxidative Damage in Mammalian Cells - PMC [pmc.ncbi.nlm.nih.gov]
- 8. Frontiers | Drug-induced mitochondrial toxicity: Risks of developing glucose handling impairments [frontiersin.org]
- 9. mdpi.com [mdpi.com]
- 10. Direct Effects of Clinically Relevant Antibiotics on Mitochondrial Respiration - PubMed [pubmed.ncbi.nlm.nih.gov]
- To cite this document: BenchChem. [Understanding the Molecular Targets of Tosufloxacin: An In-depth Technical Guide]. BenchChem, [2025]. [Online PDF]. Available at: [https://www.benchchem.com/product/b15565612#understanding-the-molecular-targets-of-tosufloxacin]

Disclaimer & Data Validity:

The information provided in this document is for Research Use Only (RUO) and is strictly not intended for diagnostic or therapeutic procedures. While BenchChem strives to provide accurate protocols, we make no warranties, express or implied, regarding the fitness of this product for every specific experimental setup.

Technical Support: The protocols provided are for reference purposes. Unsure if this reagent suits your experiment? [[Contact our Ph.D. Support Team for a compatibility check](#)]

Need Industrial/Bulk Grade? [Request Custom Synthesis Quote](#)

BenchChem

Our mission is to be the trusted global source of essential and advanced chemicals, empowering scientists and researchers to drive progress in science and industry.

Contact

Address: 3281 E Guasti Rd

Ontario, CA 91761, United States

Phone: (601) 213-4426

Email: info@benchchem.com