

Tridecanoic Acid in Gut Microbiome Studies: A Technical Guide for Researchers

Author: BenchChem Technical Support Team. **Date:** December 2025

Compound of Interest

Compound Name: *Tridecanoic acid*

Cat. No.: *B123370*

[Get Quote](#)

Affiliation: Google Research

Abstract

Tridecanoic acid (C13:0) is an odd-chain saturated fatty acid (OCSFA) of significant interest in gut microbiome research. Unlike its more common even-chain counterparts, **tridecanoic acid** is primarily produced by microbial fermentation in the gut and rumen.[1] Its unique metabolic pathway, which yields propionyl-CoA, allows it to serve anaplerotic functions for the TCA cycle and support gluconeogenesis.[1] Emerging evidence highlights its potential as a sensitive biomarker for diet-microbiome interactions and as a modulator of host physiology, including possessing direct antimicrobial properties and potential anti-inflammatory effects. This guide provides an in-depth technical overview of **tridecanoic acid**'s role in the gut microbiome, summarizing quantitative data, detailing experimental protocols, and visualizing key pathways to support advanced research and drug development.

Introduction: The Significance of an Odd-Chain Fatty Acid

Tridecanoic acid (C13H26O2) is the shortest of the long-chain OCSFAs, a class that also includes pentadecanoic (C15:0) and heptadecanoic (C17:0) acids.[1][2] While scarce in human plasma, its origins are deeply tied to microbial activity.[1] The primary sources of **tridecanoic acid** are:

- **Microbial Synthesis:** Anaerobic bacteria in the human colon and the rumen of cattle can synthesize OCSFAs through the elongation of propionate, a major short-chain fatty acid (SCFA) produced during fiber fermentation.^{[1][3]}
- **Dietary Intake:** Consumption of dairy products and certain fermented foods provides small quantities of **tridecanoic acid**.^{[1][3]}

Its metabolic fate distinguishes it from even-chain fatty acids. Beta-oxidation of **tridecanoic acid** produces propionyl-CoA, not just acetyl-CoA, which can replenish TCA cycle intermediates and influence glucose homeostasis.^[1] This unique metabolic role, combined with its direct effects on gut microbes and potential signaling capabilities, makes **tridecanoic acid** a compelling target for study in metabolic health, inflammatory conditions, and gut dysbiosis.

Quantitative Effects on Gut Microorganisms

Tridecanoic acid and its derivatives have demonstrated direct, quantifiable effects on various gastrointestinal bacteria. These effects range from bactericidal action to the inhibition of virulence-associated behaviors like biofilm formation. The following table summarizes key quantitative findings from in vitro studies.

Compound	Target Organism(s)	Effective Concentration	Observed Effect	Study Reference
Tridecanoic Acid Methyl Ester (TAME)	Enterococcus faecalis	375 µg/ml	Bactericidal; causes significant extracellular leakage and cellular disruption.	[4]
Salmonella enterica ser. Typhimurium	750 µg/ml	Bactericidal; disrupts cellular morphology.	[4]	
N-Tridecanoic Acid	Escherichia coli (EHEC)	1 mM	Effectively inhibits persister cell formation and biofilm formation without exhibiting direct antimicrobial activity against planktonic cells.	[5]

Metabolic and Signaling Pathways

The influence of **tridecanoic acid** extends from its own metabolism to the modulation of host cellular signaling, which can impact inflammation and gut barrier integrity.

Metabolic Fate of Tridecanoic Acid

The catabolism of **tridecanoic acid** via β -oxidation is a key distinguishing feature. This pathway provides a direct link between microbial fatty acid production and host central carbon metabolism.

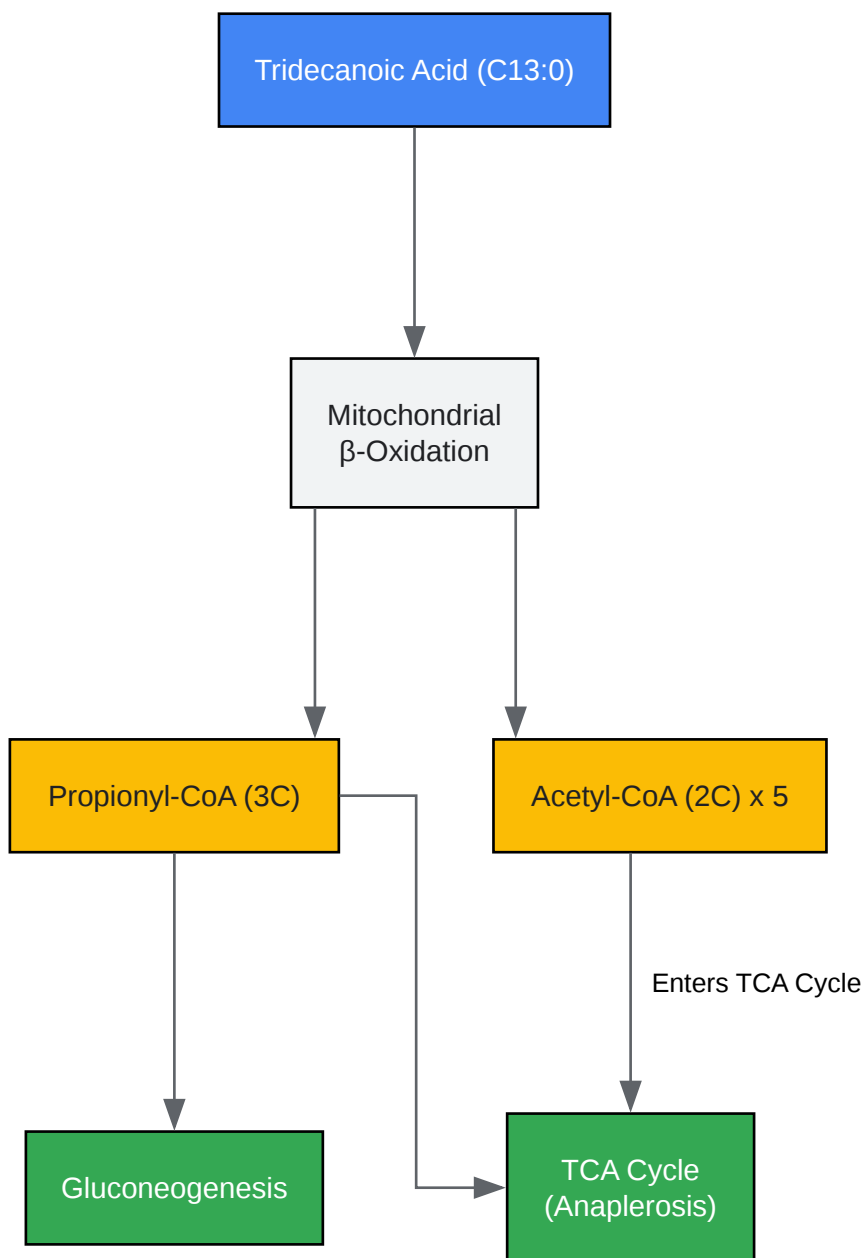

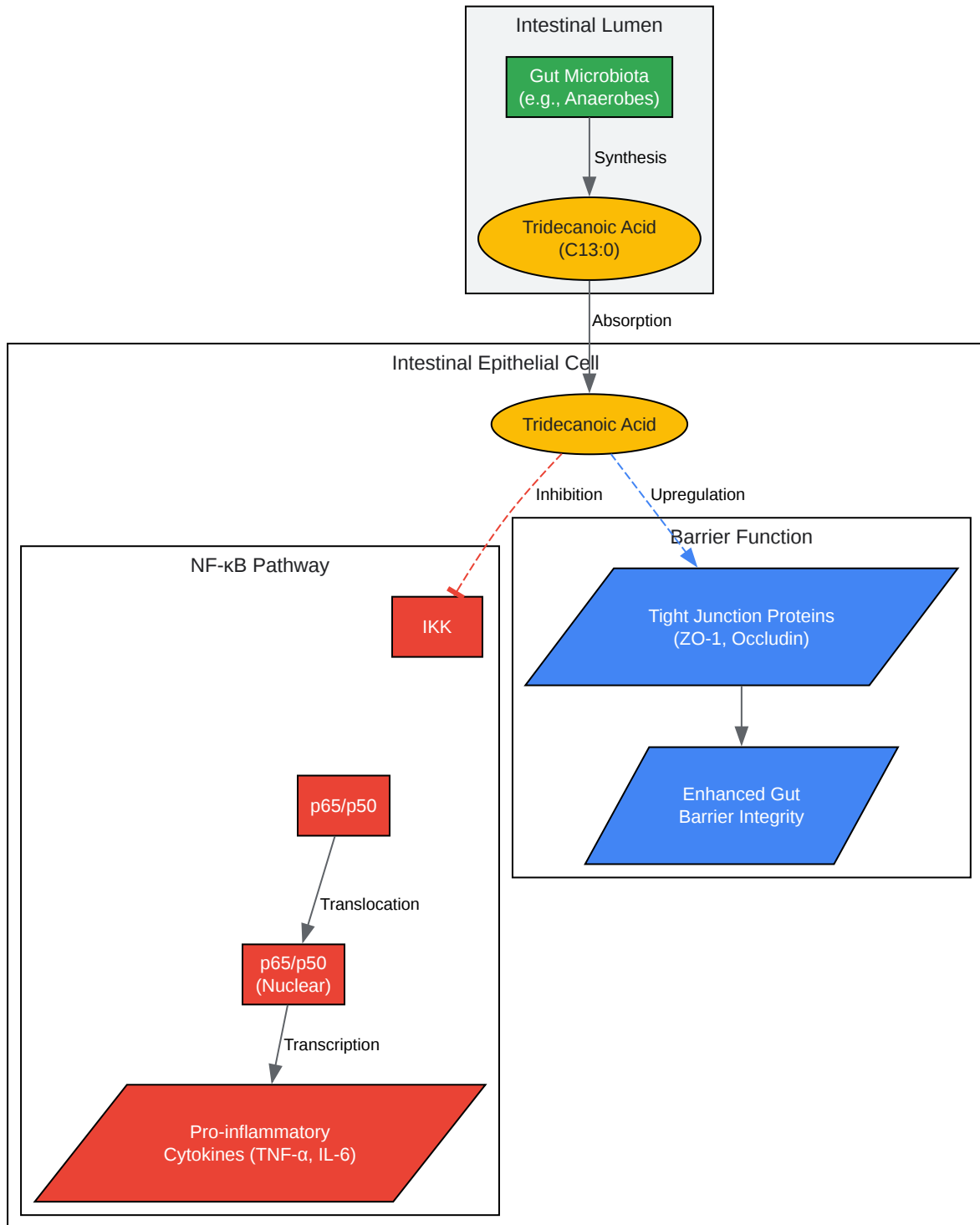

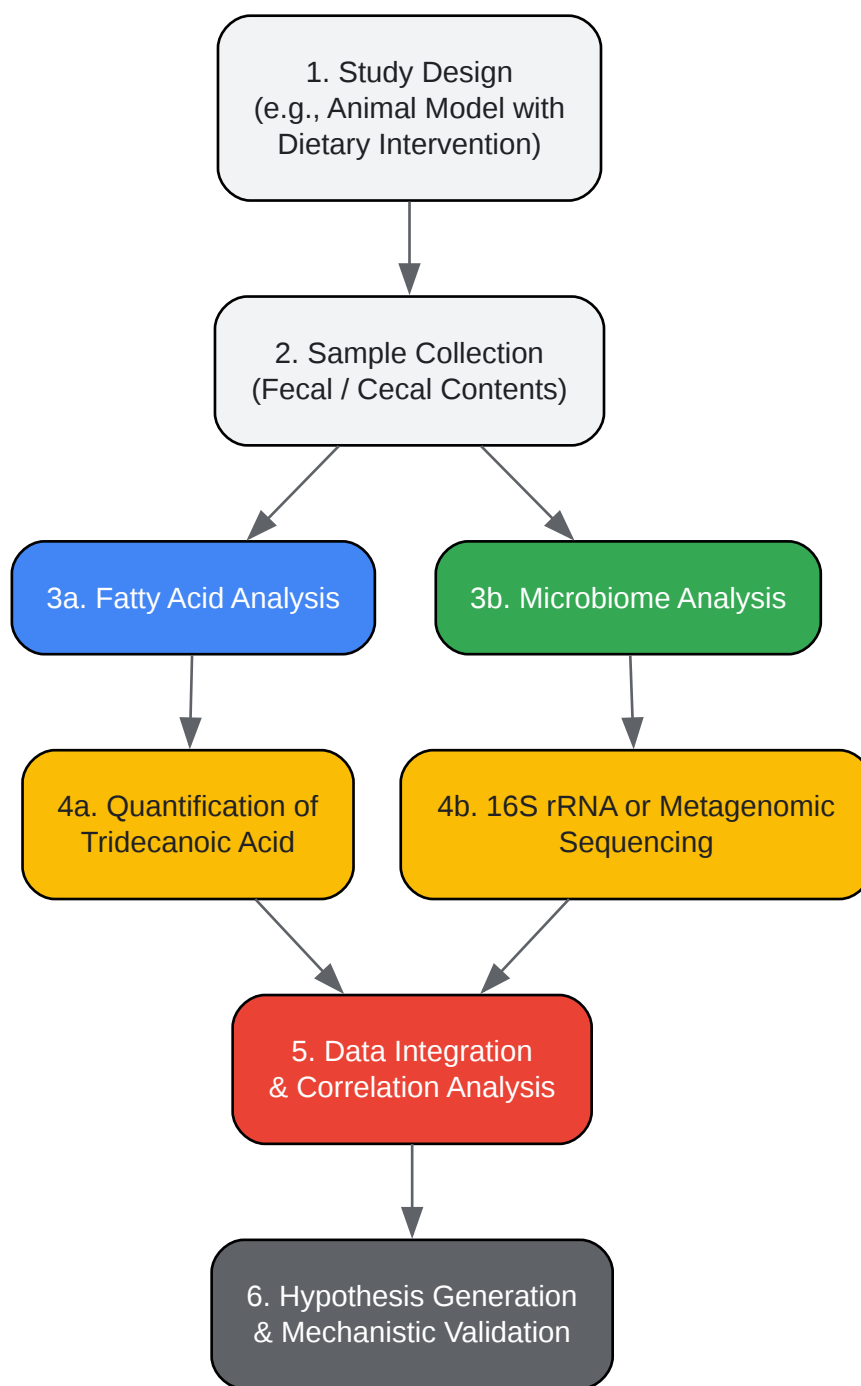

[Click to download full resolution via product page](#)

Need Custom Synthesis?

BenchChem offers custom synthesis for rare earth carbides and specific isotopic labeling.

Email: info@benchchem.com or [Request Quote Online](#).

References

- 1. news-medical.net [news-medical.net]
- 2. hmdb.ca [hmdb.ca]
- 3. benchchem.com [benchchem.com]
- 4. Anti-enteric efficacy and mode of action of tridecanoic acid methyl ester isolated from Monochoria hastata (L.) Solms leaf - PMC [pmc.ncbi.nlm.nih.gov]
- 5. Undecanoic Acid, Lauric Acid, and N-Tridecanoic Acid Inhibit Escherichia coli Persistence and Biofilm Formation - PMC [pmc.ncbi.nlm.nih.gov]
- To cite this document: BenchChem. [Tridecanoic Acid in Gut Microbiome Studies: A Technical Guide for Researchers]. BenchChem, [2025]. [Online PDF]. Available at: [https://www.benchchem.com/product/b123370#tridecanoic-acid-in-gut-microbiome-studies]

Disclaimer & Data Validity:

The information provided in this document is for Research Use Only (RUO) and is strictly not intended for diagnostic or therapeutic procedures. While BenchChem strives to provide accurate protocols, we make no warranties, express or implied, regarding the fitness of this product for every specific experimental setup.

Technical Support: The protocols provided are for reference purposes. Unsure if this reagent suits your experiment? [[Contact our Ph.D. Support Team for a compatibility check](#)]

Need Industrial/Bulk Grade? [Request Custom Synthesis Quote](#)

BenchChem

Our mission is to be the trusted global source of essential and advanced chemicals, empowering scientists and researchers to drive progress in science and industry.

Contact

Address: 3281 E Guasti Rd

Ontario, CA 91761, United States

Phone: (601) 213-4426

Email: info@benchchem.com