

The Versatility of Hexanenitrile: A Technical Guide for Chemical Intermediates

Author: BenchChem Technical Support Team. **Date:** December 2025

Compound of Interest

Compound Name: Hexanenitrile

Cat. No.: B147006

[Get Quote](#)

Introduction

Hexanenitrile, also known as capronitrile or pentyl cyanide, is a versatile aliphatic nitrile that serves as a crucial building block in a multitude of chemical syntheses.^{[1][2]} With the chemical formula C₆H₁₁N, this colorless liquid possesses a unique combination of a reactive nitrile functional group and a six-carbon chain, making it a valuable intermediate in the production of pharmaceuticals, agrochemicals, and specialty materials.^{[2][3]} This technical guide provides an in-depth overview of the synthesis, properties, and key applications of **hexanenitrile**, offering valuable insights for researchers, scientists, and professionals in drug development and chemical manufacturing.

Physicochemical and Reaction Data of Hexanenitrile

A comprehensive understanding of the physical and chemical properties of **hexanenitrile** is essential for its effective application in synthesis and process development. The following table summarizes key quantitative data for this important chemical intermediate.

Property	Value	Reference(s)
Molecular Formula	C6H11N	[2][4]
Molecular Weight	97.16 g/mol	[4]
Appearance	Colorless liquid	[1][2]
Melting Point	-80.3 °C	[1]
Boiling Point	161-164 °C	[1]
Density	0.809 g/mL at 25 °C	[1]
Refractive Index (n _{20/D})	1.406	[1]
Solubility in Water	Limited	[2]
Solubility in Organic Solvents	Soluble in ethanol and ether	[2]
Flash Point	43 °C	[1]

Synthesis of Hexanenitrile

Hexanenitrile can be synthesized through various routes, primarily involving nucleophilic substitution reactions or the dehydration of amides.

Synthesis from 1-Halopentane

A common and straightforward method for the synthesis of **hexanenitrile** is the nucleophilic substitution of a 1-halopentane (e.g., 1-bromopentane or 1-chloropentane) with a cyanide salt, such as sodium or potassium cyanide. This reaction, known as the Kolbe nitrile synthesis, is typically carried out in a polar aprotic solvent to facilitate the S_N2 mechanism.[5]

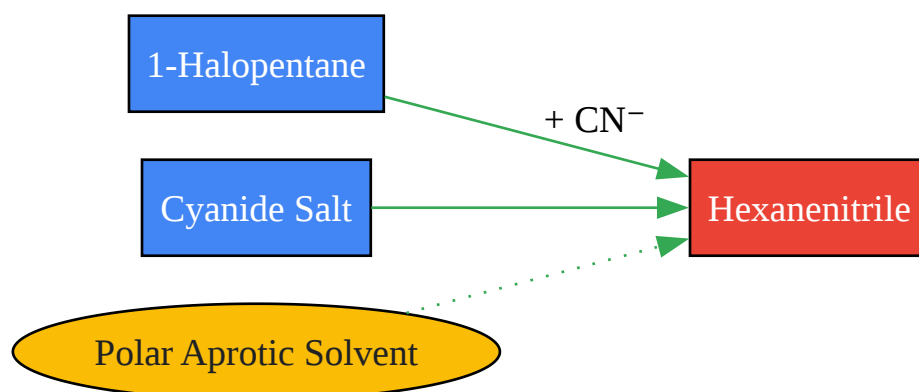

[Click to download full resolution via product page](#)

Synthesis of **Hexanenitrile** via Nucleophilic Substitution.

Dehydration of Hexanamide

Another important synthetic route is the dehydration of hexanamide. This transformation can be achieved using various dehydrating agents, with thionyl chloride (SOCl₂) and phosphorus pentoxide (P₄O₁₀) being common choices. The reaction involves the removal of a water molecule from the primary amide to form the corresponding nitrile.[3][6]

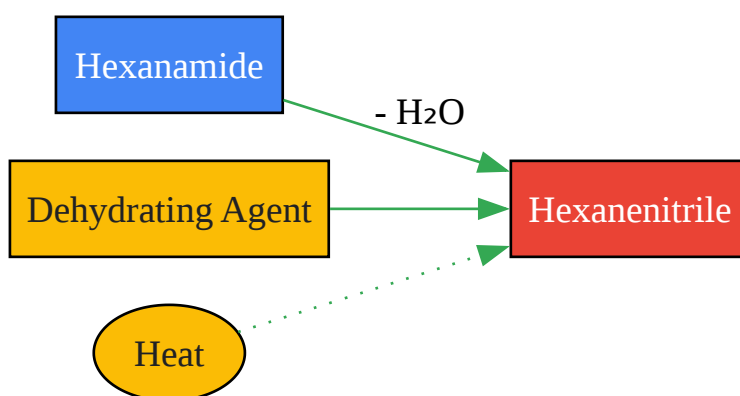

[Click to download full resolution via product page](#)

Synthesis of **Hexanenitrile** via Dehydration of Hexanamide.

Key Reactions of Hexanenitrile as a Chemical Intermediate

The reactivity of the nitrile group in **hexanenitrile** allows for its conversion into a variety of other functional groups, making it a valuable precursor in organic synthesis.

Hydrolysis to Hexanoic Acid

Hexanenitrile can be hydrolyzed to hexanoic acid under either acidic or basic conditions. Acid-catalyzed hydrolysis typically involves heating the nitrile with an aqueous solution of a strong acid, such as hydrochloric or sulfuric acid.^[7]

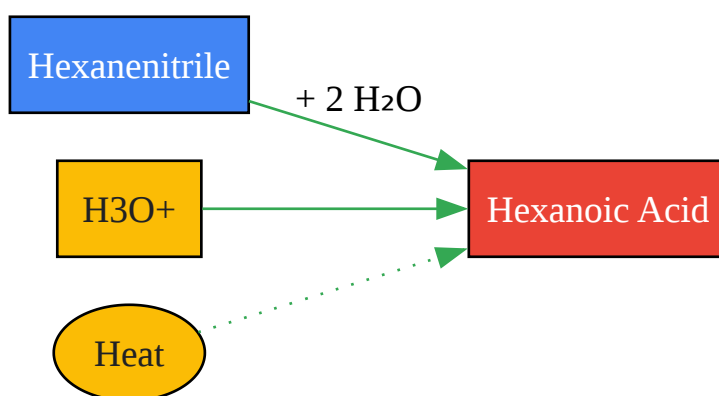

[Click to download full resolution via product page](#)

*Acid-Catalyzed Hydrolysis of **Hexanenitrile**.*

Reduction to Hexylamine

The nitrile group can be reduced to a primary amine, yielding hexylamine (1-aminohexane). Common reducing agents for this transformation include lithium aluminum hydride (LiAlH₄) and catalytic hydrogenation.

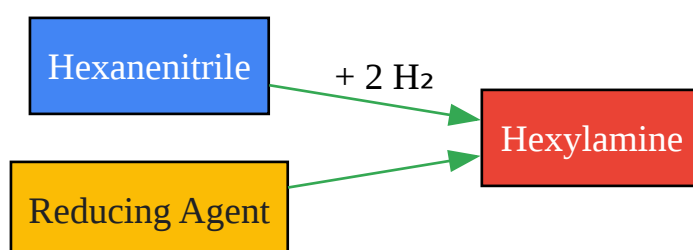

[Click to download full resolution via product page](#)

*Reduction of **Hexanenitrile** to Hexylamine.*

Reaction with Grignard Reagents

Hexanenitrile reacts with Grignard reagents to form ketones after hydrolysis of the intermediate imine. This reaction is a valuable method for the formation of carbon-carbon bonds.

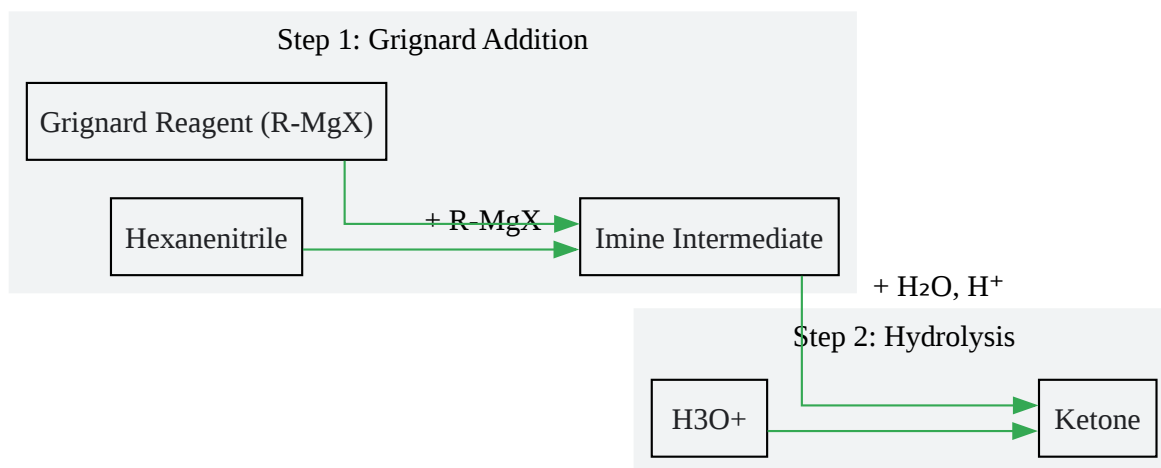

[Click to download full resolution via product page](#)

*Reaction of **Hexanenitrile** with a Grignard Reagent.*

Applications in Pharmaceutical and Agrochemical Synthesis

Hexanenitrile is a key intermediate in the synthesis of various active pharmaceutical ingredients (APIs) and agrochemicals.

Pharmaceutical Applications

While direct examples are often proprietary, the functional group transformations of **hexanenitrile** are fundamental in constructing complex molecular architectures found in pharmaceuticals. For instance, the synthesis of the antihistamine pheniramine involves the reaction of benzyl cyanide, a related nitrile, with 2-chloropyridine and subsequent alkylation.[8]

[9][10] The core reactions of nitriles, such as those described above, are integral to building the carbon skeleton and introducing key functional groups in drug molecules.

Agrochemical Applications

In the agrochemical industry, **hexanenitrile** derivatives are utilized in the synthesis of fungicides. A notable example is Myclobutanil, a triazole fungicide marketed under the trade name Systhane. The synthesis of Myclobutanil involves the construction of a chiral quaternary center containing a cyano group derived from a **hexanenitrile** backbone.[1]

Experimental Protocols

The following are generalized experimental protocols for the synthesis and key reactions of **hexanenitrile**. Researchers should consult specific literature for detailed procedures and safety information.

Synthesis of Hexanenitrile from 1-Bromopentane

Materials:

- 1-Bromopentane
- Sodium cyanide
- Dimethyl sulfoxide (DMSO)
- Diethyl ether
- Saturated aqueous sodium chloride (brine)
- Anhydrous magnesium sulfate

Procedure:

- In a round-bottom flask equipped with a magnetic stirrer and a reflux condenser, dissolve sodium cyanide in DMSO.
- Slowly add 1-bromopentane to the stirred solution.

- Heat the reaction mixture under reflux and monitor the reaction progress by TLC or GC.
- After the reaction is complete, cool the mixture to room temperature and pour it into water.
- Extract the aqueous layer with diethyl ether.
- Wash the combined organic layers with brine, dry over anhydrous magnesium sulfate, and filter.
- Remove the solvent under reduced pressure and purify the crude product by distillation to obtain **hexanenitrile**.

Hydrolysis of Hexanenitrile to Hexanoic Acid

Materials:

- **Hexanenitrile**
- Concentrated hydrochloric acid
- Diethyl ether
- Saturated aqueous sodium bicarbonate
- Anhydrous sodium sulfate

Procedure:

- In a round-bottom flask, add **hexanenitrile** and concentrated hydrochloric acid.
- Heat the mixture under reflux until the reaction is complete (as monitored by TLC or GC).
- Cool the reaction mixture and extract with diethyl ether.
- Wash the organic layer with saturated aqueous sodium bicarbonate to remove any unreacted acid.
- Dry the organic layer over anhydrous sodium sulfate, filter, and concentrate under reduced pressure to yield hexanoic acid.

Reduction of Hexanenitrile to Hexylamine

Materials:

- Lithium aluminum hydride (LiAlH₄)
- Anhydrous diethyl ether
- **Hexanenitrile**
- Aqueous sodium hydroxide solution

Procedure:

- In a flame-dried round-bottom flask under an inert atmosphere, suspend LiAlH₄ in anhydrous diethyl ether.
- Cool the suspension in an ice bath and slowly add a solution of **hexanenitrile** in anhydrous diethyl ether.
- After the addition is complete, allow the reaction to warm to room temperature and then heat to reflux.
- Monitor the reaction by TLC or GC.
- Once complete, cool the reaction in an ice bath and cautiously quench by the sequential addition of water, followed by aqueous sodium hydroxide solution, and then more water.
- Filter the resulting solid and wash it with diethyl ether.
- Dry the combined filtrate and washings over anhydrous potassium carbonate, filter, and remove the solvent to obtain hexylamine.

Conclusion

Hexanenitrile is a highly valuable and versatile chemical intermediate with broad applications in organic synthesis. Its accessible synthesis and the diverse reactivity of its nitrile functional group make it an essential precursor for a wide range of commercially important molecules,

including pharmaceuticals and agrochemicals. A thorough understanding of its properties and reaction pathways is crucial for leveraging its full potential in the development of new and innovative chemical products.

Need Custom Synthesis?

BenchChem offers custom synthesis for rare earth carbides and specific isotopic labeling.

Email: info@benchchem.com or [Request Quote Online](#).

References

- 1. First highly stereoselective synthesis of fungicide systhane - PubMed [pubmed.ncbi.nlm.nih.gov]
- 2. benchchem.com [[benchchem.com](https://www.benchchem.com)]
- 3. researchgate.net [[researchgate.net](https://www.researchgate.net)]
- 4. Hexanenitrile | C₆H₁₁N | CID 12352 - PubChem [pubchem.ncbi.nlm.nih.gov]
- 5. Nitrile synthesis by C-C coupling (cyanation) [[organic-chemistry.org](https://www.organic-chemistry.org)]
- 6. researchgate.net [[researchgate.net](https://www.researchgate.net)]
- 7. Hexanenitrile [webbook.nist.gov]
- 8. CN105175318A - Synthesis method of pheniramine maleate - Google Patents [patents.google.com]
- 9. Synthesis method of pheniramine maleate - Eureka | Patsnap [eureka.patsnap.com]
- 10. Pheniramine | C₁₆H₂₀N₂ | CID 4761 - PubChem [pubchem.ncbi.nlm.nih.gov]
- To cite this document: BenchChem. [The Versatility of Hexanenitrile: A Technical Guide for Chemical Intermediates]. BenchChem, [2025]. [Online PDF]. Available at: [<https://www.benchchem.com/product/b147006#role-of-hexanenitrile-as-a-chemical-intermediate>]

Disclaimer & Data Validity:

The information provided in this document is for Research Use Only (RUO) and is strictly not intended for diagnostic or therapeutic procedures. While BenchChem strives to provide

accurate protocols, we make no warranties, express or implied, regarding the fitness of this product for every specific experimental setup.

Technical Support: The protocols provided are for reference purposes. Unsure if this reagent suits your experiment? [[Contact our Ph.D. Support Team for a compatibility check](#)]

Need Industrial/Bulk Grade? [Request Custom Synthesis Quote](#)

BenchChem

Our mission is to be the trusted global source of essential and advanced chemicals, empowering scientists and researchers to drive progress in science and industry.

Contact

Address: 3281 E Guasti Rd

Ontario, CA 91761, United States

Phone: (601) 213-4426

Email: info@benchchem.com