

# The Stability of Apigeninidin: A Technical Guide for Researchers

**Author:** BenchChem Technical Support Team. **Date:** December 2025

## Compound of Interest

Compound Name: *Apigeninidin*

Cat. No.: *B191520*

[Get Quote](#)

An In-depth Examination of the Thermal and pH-Dependent Stability of a Promising 3-Deoxyanthocyanidin

**Apigeninidin**, a 3-deoxyanthocyanidin found in sources like sorghum, is gaining significant interest in the pharmaceutical and food industries for its potential health benefits and its properties as a natural colorant. Understanding its stability under various processing and storage conditions is paramount for its successful application. This technical guide provides a comprehensive overview of the thermal and pH stability of **Apigeninidin**, presenting key quantitative data, detailed experimental protocols, and visual representations of its chemical behavior.

## pH Stability of Apigeninidin

The stability and solubility of **Apigeninidin** are profoundly influenced by the pH of its environment. Unlike many common anthocyanins, **Apigeninidin** exhibits enhanced stability in neutral to alkaline conditions.

## Quantitative Data on pH Stability

The following table summarizes the observed stability and solubility of **Apigeninidin** at different pH values.

pH Range	Observation	Reference
1.8 - 3.0	More resistant to sulfite-induced bleaching compared to higher pH.[1][2]	[1][2]
4.0 - 6.0	In a maize porridge, thermal stability and redness were consistent.[3][4]	[3][4]
~5.0	Insoluble.[3][4]	[3][4]
6.0 - 10.0	Soluble and stable with increased color density and resistance to bleaching.[3][4]	[3][4]
9.03	Higher thermal stability in maize porridge compared to pH 4-6.[3][4]	[3][4]

## Structural Transformations of Apigeninidin with Varying pH

**Apigeninidin** undergoes structural transformations in aqueous solutions as the pH changes, existing in different chemical forms that influence its color and stability.

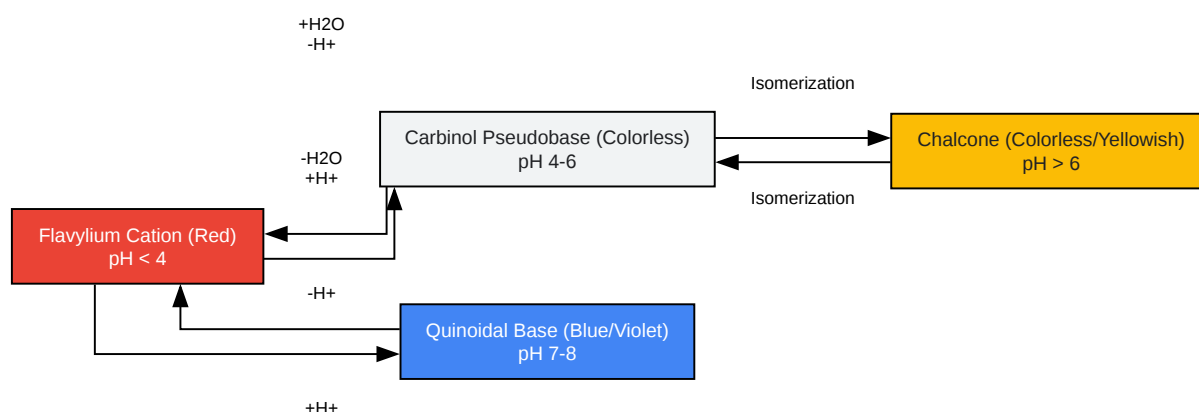

[Click to download full resolution via product page](#)

*Figure 1: pH-dependent structural transformations of **Apigeninidin**.*

## Thermal Stability of **Apigeninidin**

Temperature is a critical factor affecting the stability of **Apigeninidin**, with higher temperatures generally leading to increased degradation. The degradation kinetics often follow a first-order reaction model.

### Quantitative Data on Thermal Stability

The following table summarizes the degradation of **Apigeninidin** under various thermal conditions.

Temperature (°C)	Duration	pH	Degradation	Reference
20	-	Aqueous Solution	Follows first-order degradation kinetics.	[5]
37	-	Aqueous Solution	Follows first-order degradation kinetics with a higher degradation rate constant than at 20°C.	[5]
65	-	6.08	Degradation rate is four times higher than at pH 9.03.	[3][4]
65	-	9.03	Lower degradation rate compared to pH 6.08.	[3][4]
121	30 min	Not specified	61% degradation of total anthocyanins.	[3][4]

## Thermal Degradation Pathway

The thermal degradation of anthocyanins can proceed through the cleavage of covalent bonds and oxidation, leading to the formation of smaller molecules. While a specific detailed pathway for **Apigeninidin** is not fully elucidated in the provided context, a general representation of anthocyanin thermal degradation is presented below.

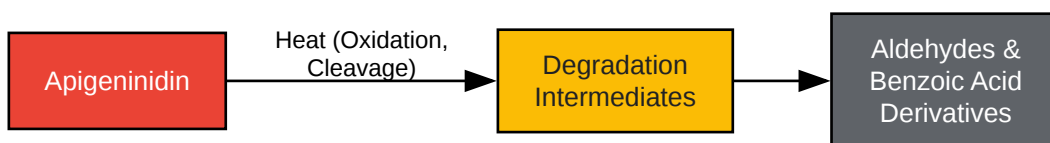

[Click to download full resolution via product page](#)

Figure 2: Generalized thermal degradation pathway for anthocyanins.

## Stability in the Presence of Additives

Food additives, such as sulfites, can significantly impact the stability of **Apigeninidin**.

### Effect of Sulfites

In the presence of sulfites, **Apigeninidin** can be bleached due to the formation of a colorless sulfonate adduct. However, this reaction can be reversible under certain pH conditions.

- Bleaching Effect: All pigments were significantly bleached within 30 minutes in the presence of sulfites, with the effect being more severe at pH 5.0 and 3.0 compared to pH 1.8.[1][2]
- Color Regain: At pH 1.8 and 3.0, the bleached color was regained within 14-21 days, indicating that the equilibrium favored the flavylium cation at these lower pH values.[1][2]
- Mechanism: The bleaching is caused by the formation of colorless sulfonates through the addition of a bisulfite ion at the C-4 position of the flavylium cation.[1][2]

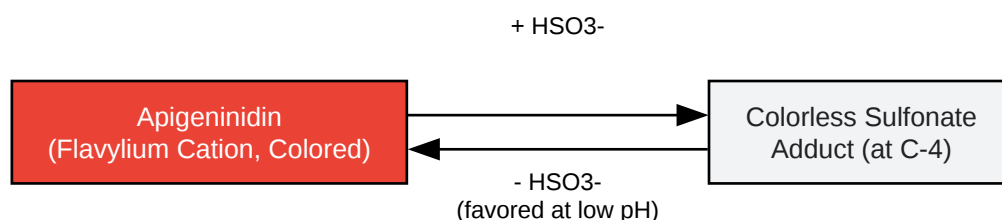

[Click to download full resolution via product page](#)

Figure 3: Reversible interaction of **Apigeninidin** with sulfites.

## Experimental Protocols

This section outlines the general methodologies employed for assessing the thermal and pH stability of **Apigeninidin**, as inferred from the literature.

## General Workflow for Stability Testing

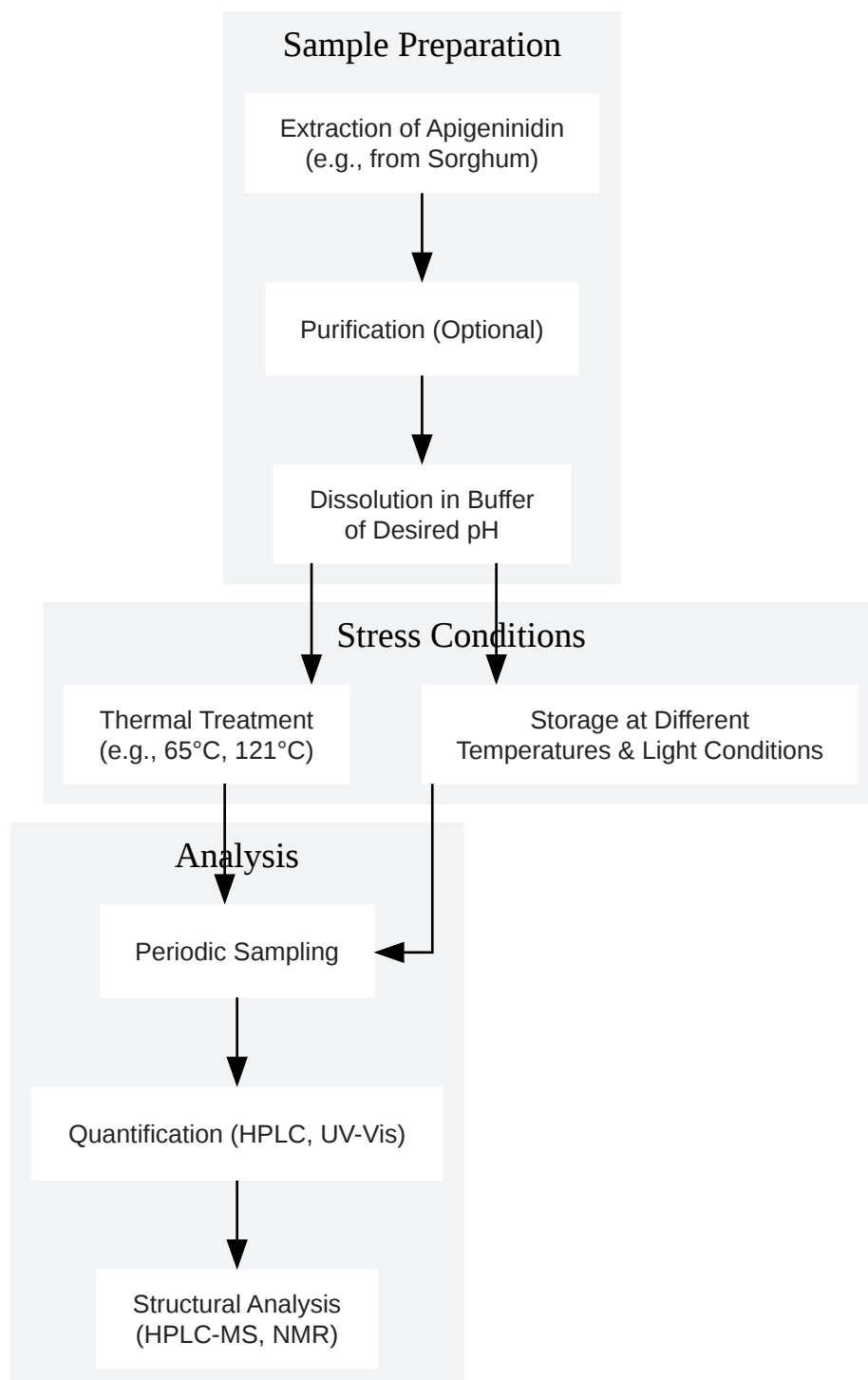

[Click to download full resolution via product page](#)

*Figure 4: General experimental workflow for stability assessment.*

## Preparation of Apigeninidin Solutions

- Extraction: **Apigeninidin** is typically extracted from its natural source, such as sorghum leaf sheaths, using an appropriate solvent system (e.g., acidified methanol or ethanol).[6]
- Purification: For detailed kinetic studies, the crude extract may be purified using chromatographic techniques to isolate **Apigeninidin**.
- Buffer Preparation: A series of buffers (e.g., citrate-phosphate, sodium acetate) are prepared to cover the desired pH range for the stability study.
- Solution Preparation: A stock solution of **Apigeninidin** is prepared and then diluted into the different pH buffers to a known concentration.

## Thermal Stability Testing

- Sample Aliquoting: The **Apigeninidin** solutions at various pH values are aliquoted into sealed vials to prevent evaporation.
- Heat Treatment: The vials are placed in a temperature-controlled environment, such as a water bath or a block heater, set to the desired experimental temperatures (e.g., 65°C, 95°C, 121°C).[4]
- Sampling: At predetermined time intervals, vials are removed from the heat source and immediately cooled in an ice bath to stop the degradation reaction.
- Analysis: The concentration of the remaining **Apigeninidin** is determined using a suitable analytical method, such as High-Performance Liquid Chromatography (HPLC) or UV-Vis spectrophotometry.[7][8]

## pH Stability Testing

- Sample Preparation: **Apigeninidin** solutions are prepared in buffers of varying pH as described above.

- **Storage:** The solutions are stored under controlled conditions (e.g., room temperature, refrigerated, in the dark) for a specified period.
- **Monitoring:** The stability is monitored over time by measuring changes in color (colorimetry), absorbance (UV-Vis spectrophotometry), and concentration (HPLC).<sup>[7][9]</sup>

## Analytical Methods

- **High-Performance Liquid Chromatography (HPLC):** This is a powerful technique for separating and quantifying individual anthocyanin compounds, providing detailed information on the concentration of **Apigeninidin** and the formation of degradation products.<sup>[7][8]</sup>
- **Liquid Chromatography-Mass Spectrometry (LC-MS):** This method combines the separation power of HPLC with the identification capabilities of mass spectrometry to identify degradation products and elucidate degradation pathways.<sup>[7][8]</sup>
- **UV-Vis Spectrophotometry (pH Differential Method):** This is a common and rapid method for determining the total anthocyanin content. It relies on the change in absorbance at specific wavelengths at different pH values.<sup>[4][9]</sup>
- **Nuclear Magnetic Resonance (NMR) Spectroscopy:** NMR is used to provide detailed structural information about **Apigeninidin** and its transformation products, which is crucial for understanding degradation mechanisms.<sup>[7][8][10]</sup>

## Conclusion

**Apigeninidin** demonstrates unique stability characteristics, particularly its enhanced stability in neutral to alkaline pH ranges, which distinguishes it from many other anthocyanins. Its thermal stability is pH-dependent, with greater stability observed at higher pH. The degradation of **Apigeninidin** generally follows first-order kinetics. Understanding these stability parameters is essential for researchers, scientists, and drug development professionals to optimize the formulation, processing, and storage of products containing this promising bioactive compound. Further research to elucidate the specific degradation products under various conditions will provide a more complete picture of its stability profile.



### Need Custom Synthesis?

BenchChem offers custom synthesis for rare earth carbides and specific isotopic labeling.

Email: [info@benchchem.com](mailto:info@benchchem.com) or [Request Quote Online](#).

## References

- 1. Stability of apigeninidin and its methoxylated derivatives in the presence of sulfites - PubMed [pubmed.ncbi.nlm.nih.gov]
- 2. pubs.acs.org [pubs.acs.org]
- 3. bec.uac.bj [bec.uac.bj]
- 4. researchgate.net [researchgate.net]
- 5. The Stability and Activity Changes of Apigenin and Luteolin in Human Cervical Cancer Hela Cells in Response to Heat Treatment and Fe<sup>2+</sup>/Cu<sup>2+</sup> Addition - PMC [pmc.ncbi.nlm.nih.gov]
- 6. download.garuda.kemdikbud.go.id [download.garuda.kemdikbud.go.id]
- 7. Anthocyanin detection analysis - Eurofins Scientific [eurofins.in]
- 8. atlantis-press.com [atlantis-press.com]
- 9. pubs.aip.org [pubs.aip.org]
- 10. researchgate.net [researchgate.net]
- To cite this document: BenchChem. [The Stability of Apigeninidin: A Technical Guide for Researchers]. BenchChem, [2025]. [Online PDF]. Available at: [https://www.benchchem.com/product/b191520#thermal-and-ph-stability-of-apigeninidin]

---

### Disclaimer & Data Validity:

The information provided in this document is for Research Use Only (RUO) and is strictly not intended for diagnostic or therapeutic procedures. While BenchChem strives to provide accurate protocols, we make no warranties, express or implied, regarding the fitness of this product for every specific experimental setup.

**Technical Support:** The protocols provided are for reference purposes. Unsure if this reagent suits your experiment? [[Contact our Ph.D. Support Team for a compatibility check](#)]

**Need Industrial/Bulk Grade?** [Request Custom Synthesis Quote](#)

## BenchChem

Our mission is to be the trusted global source of essential and advanced chemicals, empowering scientists and researchers to drive progress in science and industry.

### Contact

Address: 3281 E Guasti Rd  
Ontario, CA 91761, United States  
Phone: (601) 213-4426  
Email: [info@benchchem.com](mailto:info@benchchem.com)