

The Role of Lysophosphatidylethanolamines in Cellular Signaling: An In-depth Technical Guide

Author: BenchChem Technical Support Team. **Date:** December 2025

Compound of Interest

Compound Name: *1-Palmitoyl-d9-2-hydroxy-sn-glycero-3-PE*

Cat. No.: *B10782655*

[Get Quote](#)

For Researchers, Scientists, and Drug Development Professionals

Introduction

Lysophosphatidylethanolamines (LPEs) are a class of lysophospholipids derived from the partial hydrolysis of phosphatidylethanolamine by phospholipase A2.[1] For a long time, LPEs were considered minor components of cell membranes with unknown physiological significance. However, emerging evidence has highlighted their role as bioactive lipid mediators involved in a variety of cellular processes through intricate signaling pathways. This technical guide provides a comprehensive overview of the current understanding of LPE signaling, with a focus on their receptors, downstream signaling cascades, and the experimental methodologies used to elucidate their functions.

LPE Receptors and Downstream Signaling Pathways

LPEs exert their effects primarily through G-protein coupled receptors (GPCRs). While dedicated LPE receptors are yet to be definitively identified, several studies have shown that LPEs can act as ligands for other lysophospholipid receptors, most notably the lysophosphatidic acid receptor 1 (LPA1). However, the involvement of LPA1 in LPE signaling appears to be cell-type specific.[2][3]

Signaling in MDA-MB-231 Breast Cancer Cells

In the human breast cancer cell line MDA-MB-231, LPE has been shown to induce an increase in intracellular calcium concentration ($[Ca^{2+}]_i$) by signaling through the LPA1 receptor.[1] This signaling cascade involves the activation of Gai/o proteins, which in turn activate Phospholipase C (PLC). PLC catalyzes the hydrolysis of phosphatidylinositol 4,5-bisphosphate (PIP₂) into inositol 1,4,5-trisphosphate (IP₃) and diacylglycerol (DAG). IP₃ then binds to its receptor on the endoplasmic reticulum, leading to the release of stored calcium into the cytoplasm. Interestingly, not all LPE species are active in this cell line; for instance, 14:0 and 18:1 LPE induce a calcium response, whereas 16:0, 18:0, and ether-linked 18:0 LPE do not.[1]

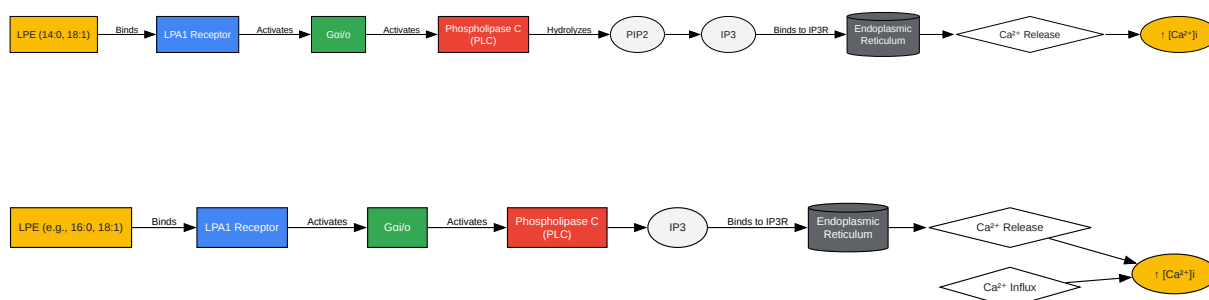

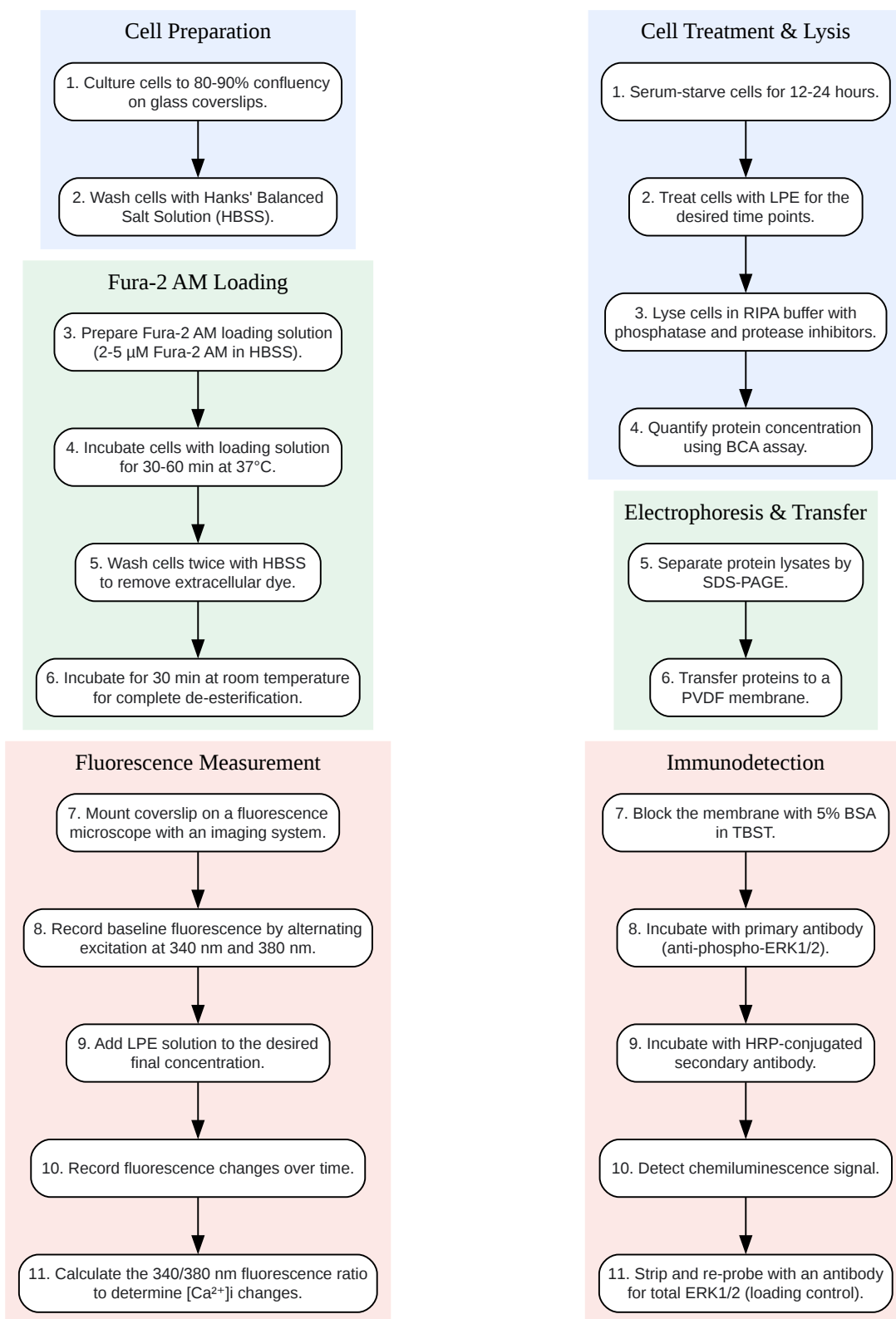

[Click to download full resolution via product page](#)

Need Custom Synthesis?

BenchChem offers custom synthesis for rare earth carbides and specific isotopic labeling.

Email: info@benchchem.com or [Request Quote Online](#).

References

- 1. The GPR55 ligand L-alpha-lysophosphatidylinositol promotes RhoA-dependent Ca²⁺ signaling and NFAT activation - PubMed [pubmed.ncbi.nlm.nih.gov]
- 2. The GPR55 agonist lysophosphatidylinositol directly activates intermediate-conductance Ca²⁺ -activated K⁺ channels - PubMed [pubmed.ncbi.nlm.nih.gov]
- 3. The GPR55 agonist lysophosphatidylinositol relaxes rat mesenteric resistance artery and induces Ca²⁺ release in rat mesenteric artery endothelial cells - PMC [pmc.ncbi.nlm.nih.gov]
- To cite this document: BenchChem. [The Role of Lysophosphatidylethanolamines in Cellular Signaling: An In-depth Technical Guide]. BenchChem, [2025]. [Online PDF]. Available at: [https://www.benchchem.com/product/b10782655#role-of-lysophosphatidylethanolamines-in-cellular-signaling]

Disclaimer & Data Validity:

The information provided in this document is for Research Use Only (RUO) and is strictly not intended for diagnostic or therapeutic procedures. While BenchChem strives to provide accurate protocols, we make no warranties, express or implied, regarding the fitness of this product for every specific experimental setup.

Technical Support: The protocols provided are for reference purposes. Unsure if this reagent suits your experiment? [[Contact our Ph.D. Support Team for a compatibility check](#)]

Need Industrial/Bulk Grade? [Request Custom Synthesis Quote](#)

BenchChem

Our mission is to be the trusted global source of essential and advanced chemicals, empowering scientists and researchers to drive progress in science and industry.

Contact

Address: 3281 E Guasti Rd

Ontario, CA 91761, United States

Phone: (601) 213-4426

Email: info@benchchem.com