

The Role of ICA-069673 in Epilepsy Research: A Technical Guide

Author: BenchChem Technical Support Team. **Date:** December 2025

Compound of Interest

Compound Name: ICA-069673

Cat. No.: B1674252

[Get Quote](#)

An In-depth Whitepaper for Researchers, Scientists, and Drug Development Professionals

Executive Summary

Epilepsy, a neurological disorder characterized by recurrent seizures, affects millions worldwide. A significant portion of patients exhibit resistance to currently available antiepileptic drugs (AEDs), highlighting the urgent need for novel therapeutic strategies. One promising avenue of research focuses on the modulation of neuronal excitability through the activation of voltage-gated potassium channels. This technical guide delves into the core of this approach by examining the role of **ICA-069673**, a selective opener of the KCNQ2/Q3 (Kv7.2/7.3) potassium channels. These channels are critical regulators of neuronal firing rates and their activation represents a key mechanism for seizure suppression. This document provides a comprehensive overview of **ICA-069673**, including its mechanism of action, quantitative efficacy data, and detailed experimental protocols for its evaluation, intended to serve as a valuable resource for professionals in the field of epilepsy research and drug development.

Introduction: Targeting Neuronal Hyperexcitability in Epilepsy

The hallmark of epileptic seizures is the excessive and synchronous firing of neurons. A primary strategy in the development of AEDs is to reduce this hyperexcitability.[1] Many existing drugs achieve this by modulating voltage-gated ion channels, enhancing inhibitory neurotransmission, or attenuating excitatory neurotransmission.[1] The KCNQ (or Kv7) family

of voltage-gated potassium channels, particularly the heteromeric KCNQ2/Q3 channels, play a crucial role in stabilizing the neuronal membrane potential and controlling firing thresholds.[2] The M-current, a slowly activating and non-inactivating potassium current mediated by KCNQ2/Q3 channels, acts as a powerful brake on repetitive firing.[2][3] Therefore, compounds that enhance the activity of KCNQ2/Q3 channels, known as channel openers, are of significant interest as potential AEDs.

ICA-069673 has emerged as a potent and selective opener of KCNQ2/Q3 channels.[2] Its distinct mechanism of action offers a targeted approach to seizure control with the potential for a favorable side-effect profile compared to less selective agents. This guide will explore the preclinical data that underscores the potential of **ICA-069673** in epilepsy research.

Mechanism of Action of ICA-069673

ICA-069673 exerts its anticonvulsant effects by directly modulating the function of KCNQ2/Q3 potassium channels. Its primary mechanism involves:

- **Positive Allosteric Modulation:** **ICA-069673** binds to a site on the KCNQ2/Q3 channel, distinct from the pore region, and allosterically enhances its opening probability.[2]
- **Hyperpolarizing Shift in Activation:** The binding of **ICA-069673** causes a leftward shift in the voltage-dependence of channel activation, meaning the channels open at more hyperpolarized membrane potentials.[2][4]
- **Increased M-Current:** This enhanced channel activity leads to an increase in the M-current, which hyperpolarizes the neuronal membrane and raises the threshold for action potential firing.[2][5]
- **Reduced Neuronal Excitability:** By increasing the potassium efflux, **ICA-069673** effectively dampens neuronal excitability, making neurons less likely to fire repetitively and thereby suppressing seizure activity.[5]

The following diagram illustrates the signaling pathway of **ICA-069673**'s action:

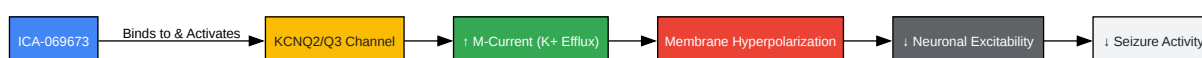

[Click to download full resolution via product page](#)

Figure 1: Signaling pathway of **ICA-069673**. This diagram illustrates how **ICA-069673** activates KCNQ2/Q3 channels to reduce seizure activity.

Quantitative Data Presentation

The following tables summarize the key quantitative data for **ICA-069673** from various preclinical studies.

Table 1: In Vitro Potency and Selectivity

Parameter	Channel Subtype	Value	Reference
EC50	KCNQ2/Q3	0.52 μ M	[4]
EC50	KCNQ2/Q3	0.69 μ M	[6]
Selectivity	KCNQ2/Q3 vs. KCNQ3/Q5	~20-fold	[7]

Table 2: Electrophysiological Effects on Neuronal Properties

Parameter	Effect of ICA-069673 (10 μ M)	Quantitative Change	Reference
Resting Membrane Potential	Hyperpolarization	From -61.2 ± 4.3 mV to -69.2 ± 5.0 mV	[8]
Voltage of 50% Activation (V0.5)	Hyperpolarizing Shift	-25.5 ± 4.1 mV	[4]
Maximal Conductance (Gmax)	Increase	From 8.1 ± 4.0 to 12.6 ± 7.4 nS/pF	[4]
Rheobase (Current to evoke AP)	Increase	~3-fold increase	[5]
Input Resistance	Decrease	Significant reduction	[8]

Experimental Protocols

This section provides detailed methodologies for key experiments used to evaluate the efficacy of **ICA-069673**.

Whole-Cell Patch-Clamp Electrophysiology

This in vitro technique is crucial for characterizing the direct effects of **ICA-069673** on KCNQ2/Q3 channels.

Objective: To measure the effects of **ICA-069673** on the biophysical properties of KCNQ2/Q3 channels, including current density, voltage-dependence of activation, and activation/deactivation kinetics.

Methodology:

- Cell Culture and Transfection:
 - Human Embryonic Kidney (HEK293) cells are cultured in Dulbecco's Modified Eagle Medium (DMEM) supplemented with 10% fetal bovine serum and 1% penicillin-streptomycin.
 - Cells are transiently transfected with plasmids encoding human KCNQ2 and KCNQ3 subunits using a suitable transfection reagent (e.g., Lipofectamine). A fluorescent reporter plasmid (e.g., GFP) is often co-transfected to identify successfully transfected cells.
 - Recordings are typically performed 24-48 hours post-transfection.[9]
- Electrophysiological Recording:
 - External Solution (in mM): 140 NaCl, 4 KCl, 2 CaCl₂, 1 MgCl₂, 10 HEPES, and 10 glucose (pH adjusted to 7.4 with NaOH).
 - Internal (Pipette) Solution (in mM): 140 KCl, 1 MgCl₂, 10 EGTA, 10 HEPES, and 4 Mg-ATP (pH adjusted to 7.2 with KOH).[10]
 - Borosilicate glass pipettes are pulled to a resistance of 3-7 MΩ when filled with the internal solution.

- Whole-cell patch-clamp recordings are performed at room temperature using an appropriate amplifier and data acquisition system.
- Voltage Protocols:
 - To measure the voltage-dependence of activation: Cells are held at a holding potential of -80 mV. A series of depolarizing voltage steps (e.g., from -100 mV to +40 mV in 10 mV increments for 500 ms) are applied. Tail currents are then measured upon repolarization to a fixed potential (e.g., -60 mV).[7]
 - The conductance (G) is calculated from the tail current amplitude and plotted against the prepulse potential. The data is then fitted with a Boltzmann function to determine the $V_{0.5}$ and slope factor.
- Drug Application:
 - **ICA-069673** is dissolved in dimethyl sulfoxide (DMSO) to create a stock solution and then diluted to the final desired concentrations in the external solution.
 - The compound is applied to the cells via a perfusion system.

The following diagram outlines the experimental workflow for whole-cell patch-clamp analysis:

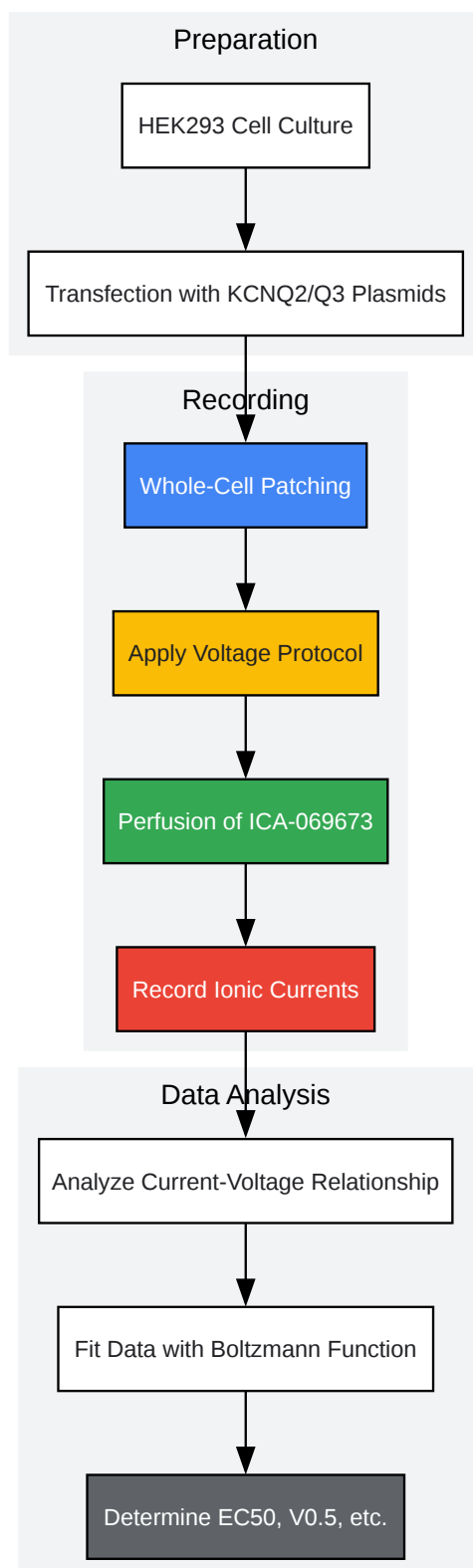

[Click to download full resolution via product page](#)

Figure 2: Experimental workflow for whole-cell patch-clamp analysis of **ICA-069673**.

Maximal Electroshock Seizure (MES) Test

The MES test is a widely used in vivo model to screen for anticonvulsant drugs effective against generalized tonic-clonic seizures.[11]

Objective: To assess the ability of **ICA-069673** to prevent the tonic hindlimb extension phase of a maximal electroshock-induced seizure.

Methodology:

- Animals: Adult male mice (e.g., Swiss albino, 20-25 g) or rats are used.[12]
- Drug Administration: **ICA-069673** is typically administered intraperitoneally (i.p.) or orally (p.o.) at various doses. A vehicle control group is always included. The test is conducted at the time of predicted peak drug effect, determined from pharmacokinetic studies.
- Seizure Induction:
 - A corneal or ear-clip electrode is used to deliver an electrical stimulus.
 - For mice, a common stimulus parameter is 50 mA at 60 Hz for 0.2 seconds.[13]
 - For rats, a stimulus of 150 mA at 60 Hz for 0.2 seconds is often used.[13]
- Endpoint: The primary endpoint is the presence or absence of a tonic hindlimb extension lasting for at least 3 seconds. Protection is defined as the absence of this endpoint.
- Data Analysis: The percentage of animals protected at each dose is calculated. The ED50 (the dose that protects 50% of the animals) can be determined using probit analysis.

Pentylentetrazol (PTZ) Kindling Model

The PTZ kindling model is a chronic model of epilepsy that mimics the development of spontaneous recurrent seizures (epileptogenesis).[14][15]

Objective: To evaluate the effect of **ICA-069673** on the development and expression of PTZ-induced kindled seizures.

Methodology:

- Animals: Adult male mice or rats are used.
- Kindling Induction:
 - A subconvulsive dose of PTZ (e.g., 30-40 mg/kg, i.p.) is administered every other day.[14]
 - Immediately after each injection, the animals are observed for 30 minutes, and the seizure severity is scored according to a standardized scale (e.g., Racine scale).[15]
 - The injections are repeated until the animals consistently exhibit a generalized tonic-clonic seizure (fully kindled).
- Drug Administration:
 - To assess anti-epileptogenic effects: **ICA-069673** is administered before each PTZ injection during the kindling acquisition phase.
 - To assess anticonvulsant effects in kindled animals: **ICA-069673** is administered to fully kindled animals prior to a challenge dose of PTZ.
- Endpoint: The primary endpoints are the seizure score after each PTZ injection and the number of injections required to reach a fully kindled state.
- Data Analysis: The mean seizure scores and the rate of kindling development are compared between the drug-treated and vehicle control groups.

The following diagram illustrates the logical relationship in preclinical epilepsy model testing:

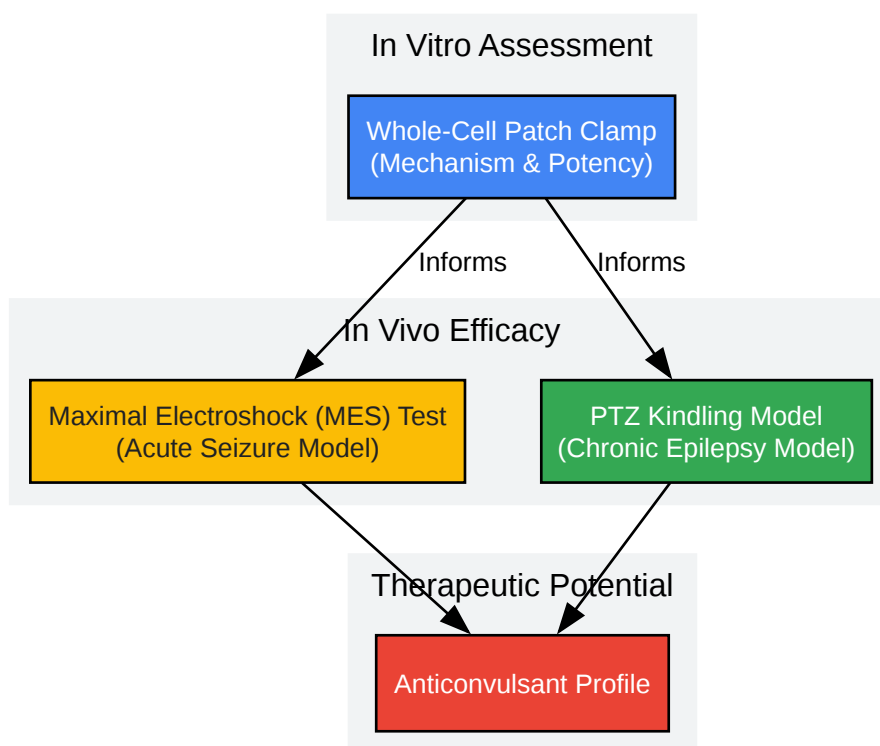

[Click to download full resolution via product page](#)

Figure 3: Logical flow of preclinical evaluation for an antiepileptic drug candidate like **ICA-069673**.

Conclusion and Future Directions

ICA-069673 represents a significant advancement in the targeted therapy for epilepsy. Its selective activation of KCNQ2/Q3 channels provides a direct mechanism to counteract the neuronal hyperexcitability that underlies seizure generation. The preclinical data strongly support its potential as an anticonvulsant. The detailed experimental protocols provided in this guide offer a framework for the continued investigation of **ICA-069673** and other KCNQ channel openers.

Future research should focus on:

- Elucidating the full spectrum of its anticonvulsant activity in a wider range of preclinical epilepsy models, including those resistant to current AEDs.

- Investigating its pharmacokinetic and pharmacodynamic properties in more detail to optimize dosing and administration regimens.
- Exploring its potential in combination therapies with other AEDs to enhance efficacy and reduce side effects.
- Advancing promising candidates into clinical trials to ultimately translate these preclinical findings into tangible benefits for patients with epilepsy.

The continued exploration of selective KCNQ channel modulators like **ICA-069673** holds great promise for the development of more effective and better-tolerated treatments for epilepsy.

Need Custom Synthesis?

BenchChem offers custom synthesis for rare earth carbides and specific isotopic labeling.

Email: info@benchchem.com or [Request Quote Online](#).

References

1. academic.oup.com [academic.oup.com]
2. researchgate.net [researchgate.net]
3. Properties of single M-type KCNQ2/KCNQ3 potassium channels expressed in mammalian cells - PMC [pmc.ncbi.nlm.nih.gov]
4. researchgate.net [researchgate.net]
5. Selective KCNQ2/3 Potassium Channel Opener ICA-069673 Inhibits Excitability in Mouse Vagal Sensory Neurons - PubMed [pubmed.ncbi.nlm.nih.gov]
6. ICA 069673 | Voltage-gated Potassium (KV) Channels | Tocris Bioscience [tocris.com]
7. Redirecting [linkinghub.elsevier.com]
8. Selective KCNQ2/3 Potassium Channel Opener ICA-069673 Inhibits Excitability in Mouse Vagal Sensory Neurons - PMC [pmc.ncbi.nlm.nih.gov]
9. Whole-cell patch-clamp recording of recombinant voltage-sensitive Ca²⁺ channels heterologously expressed in HEK-293 cells - PubMed [pubmed.ncbi.nlm.nih.gov]
10. docs.axolbio.com [docs.axolbio.com]

- 11. Acute Seizure Tests Used in Epilepsy Research: Step-by-Step Protocol of the Maximal Electroshock Seizure (MES) Test, the Maximal Electroshock Seizure Threshold (MEST) Test, and the Pentylentetrazole (PTZ)-Induced Seizure Test in Rodents | Springer Nature Experiments [experiments.springernature.com]
- 12. meliordiscovery.com [meliordiscovery.com]
- 13. mdpi.com [mdpi.com]
- 14. 2024.sci-hub.ru [2024.sci-hub.ru]
- 15. archepilepsy.org [archepilepsy.org]
- To cite this document: BenchChem. [The Role of ICA-069673 in Epilepsy Research: A Technical Guide]. BenchChem, [2025]. [Online PDF]. Available at: [https://www.benchchem.com/product/b1674252#the-role-of-ica-069673-in-epilepsy-research]

Disclaimer & Data Validity:

The information provided in this document is for Research Use Only (RUO) and is strictly not intended for diagnostic or therapeutic procedures. While BenchChem strives to provide accurate protocols, we make no warranties, express or implied, regarding the fitness of this product for every specific experimental setup.

Technical Support: The protocols provided are for reference purposes. Unsure if this reagent suits your experiment? [[Contact our Ph.D. Support Team for a compatibility check](#)]

Need Industrial/Bulk Grade? [Request Custom Synthesis Quote](#)

BenchChem

Our mission is to be the trusted global source of essential and advanced chemicals, empowering scientists and researchers to drive progress in science and industry.

Contact

Address: 3281 E Guasti Rd
Ontario, CA 91761, United States
Phone: (601) 213-4426
Email: info@benchchem.com