

The Role of Diazirines in Identifying Unknown Protein Functions: A Technical Guide

Author: BenchChem Technical Support Team. **Date:** December 2025

Compound of Interest

Compound Name: Diazoline

Cat. No.: B1670410

[Get Quote](#)

1.0 Introduction

Elucidating the function of unknown proteins and mapping their complex interaction networks is a cornerstone of modern biology and a critical step in drug discovery.^[1] While various genetic and biochemical methods exist, identifying transient or weak interactions remains a significant challenge. Photoaffinity Labeling (PAL) has emerged as a powerful chemical proteomics technique to address this, enabling the covalent capture of non-covalent molecular interactions in their native biological context.^{[1][2]}

Among the repertoire of photoreactive groups used in PAL, diazirines have become the gold standard.^{[1][3]} These small, three-membered ring compounds offer a unique combination of stability, minimal steric hindrance, and efficient photoactivation, making them an invaluable tool for covalently trapping and subsequently identifying the binding partners of small molecules, metabolites, and other proteins.^{[4][5][6]} This guide provides a technical overview of diazine chemistry, experimental workflows, and data interpretation for researchers aiming to unravel unknown protein functions.

2.0 Core Principles of Diazirine Chemistry

2.1 Structure and Stability A diazine is a compact three-membered ring containing a carbon and two nitrogen atoms (C-N=N).^[4] Key advantages of this structure include:

- **Small Size:** Diazirines are nearly isosteric with a methyl group, allowing them to be incorporated into probes with minimal perturbation of the parent molecule's structure and

biological activity.[5][7]

- **Chemical Stability:** They are remarkably stable in the dark and tolerant of various chemical conditions, including acidic and basic environments, as well as the presence of nucleophiles, which facilitates probe synthesis and handling.[4][8]

2.2 Mechanism of Photoactivation The utility of diazirines lies in their ability to transform into a highly reactive species upon UV irradiation. The process is initiated by exposing the diazirine-containing probe to long-wave UV light, typically in the 350-370 nm range, which is less damaging to biological macromolecules compared to the shorter wavelengths required for other photocrosslinkers.[8][9][10]

Upon photoactivation, the diazirine ring loses a molecule of dinitrogen (N_2) to generate a highly reactive carbene intermediate.[4][7] Recent studies have revealed a more complex mechanism, particularly for alkyl diazirines, where an initial rearrangement forms a linear diazo intermediate. This diazo species can either react directly with nucleophilic amino acid residues or undergo further photolysis to form the carbene.[2][11][12] The carbene, being highly reactive and short-lived, rapidly and indiscriminately inserts into nearby chemical bonds, including C-H, O-H, and N-H bonds of interacting proteins, forming a stable, covalent crosslink.[4][7]

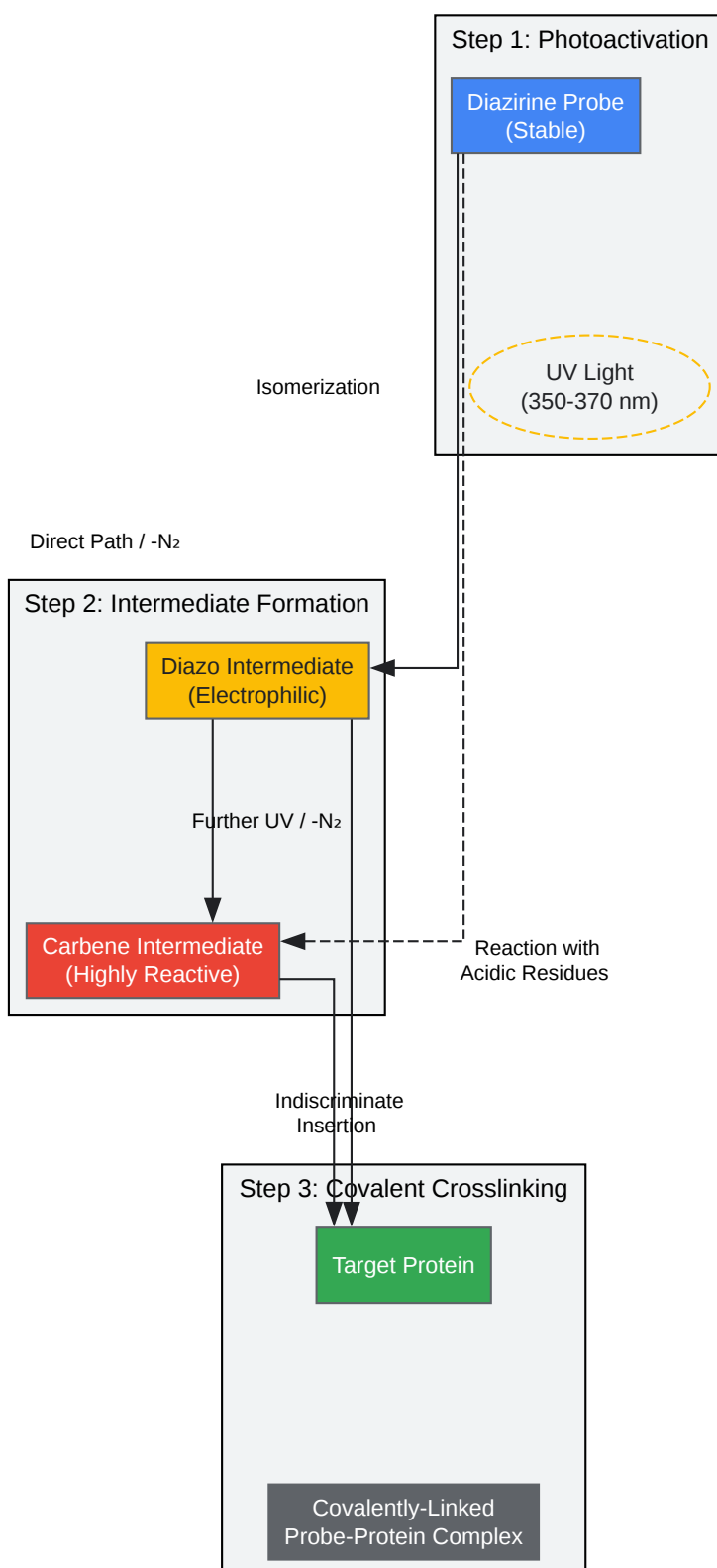

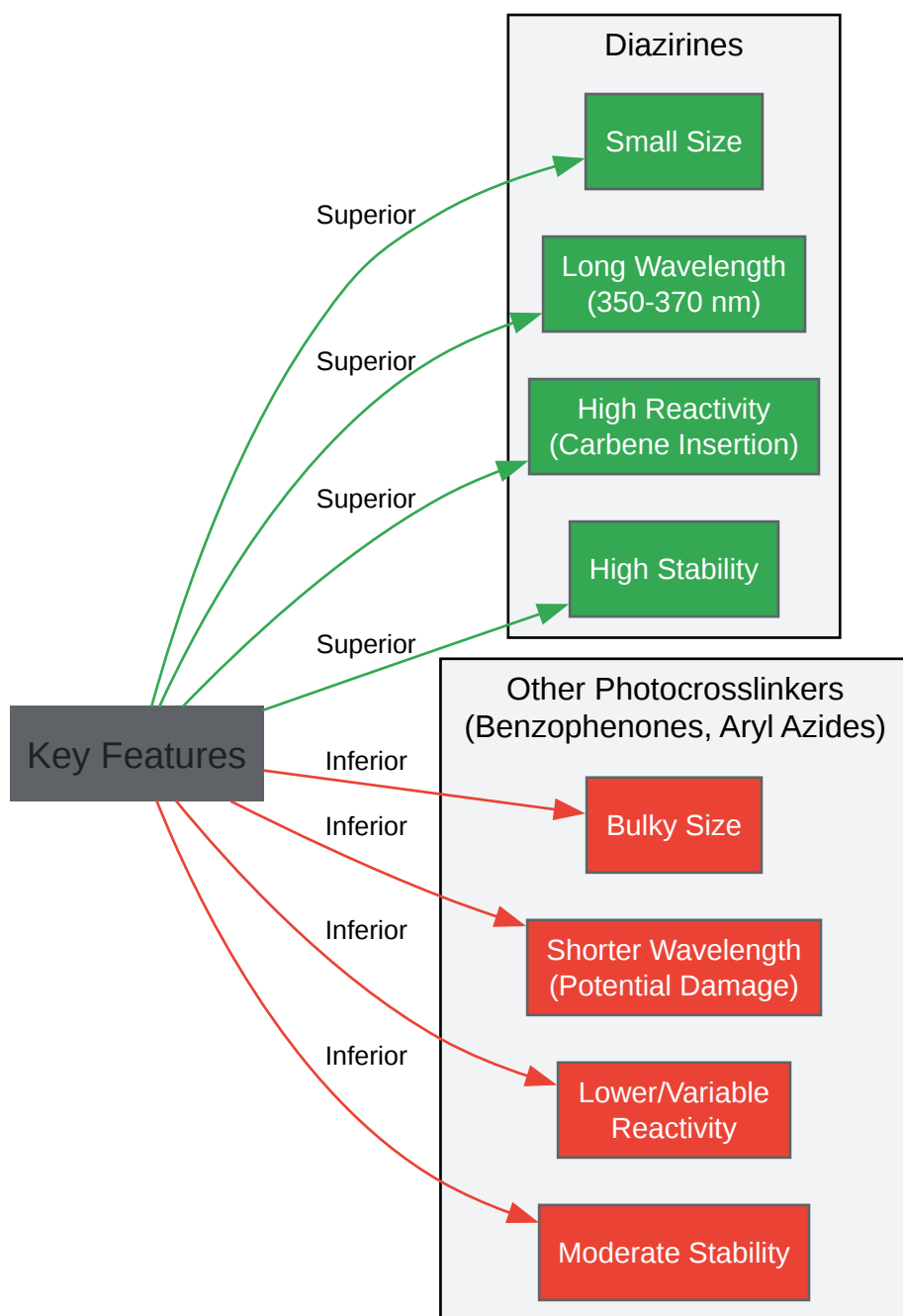

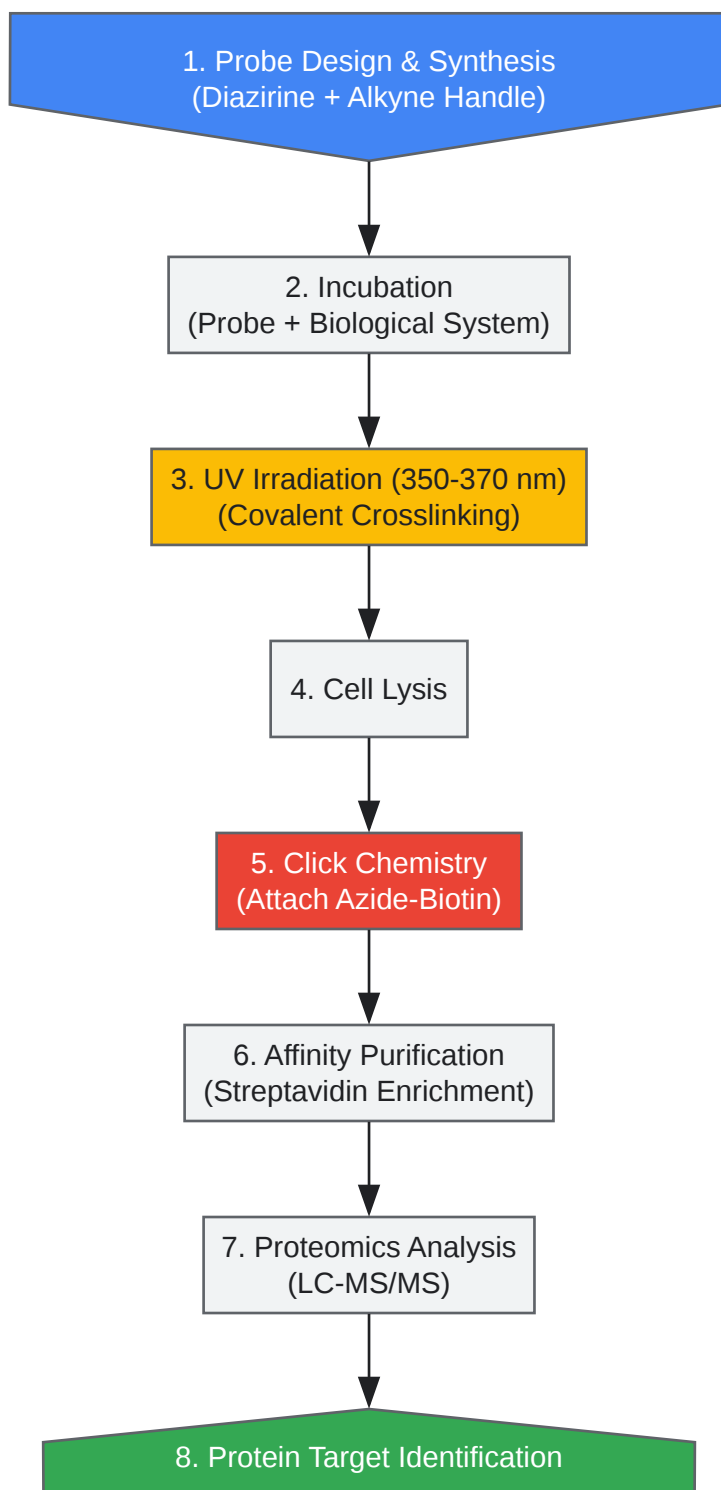

[Click to download full resolution via product page](#)

Need Custom Synthesis?

BenchChem offers custom synthesis for rare earth carbides and specific isotopic labeling.

Email: info@benchchem.com or [Request Quote Online](#).

References

- 1. Recent Applications of Diazirines in Chemical Proteomics - PubMed [pubmed.ncbi.nlm.nih.gov]
- 2. Photoaffinity Labelling Strategies for Mapping the Small Molecule-Protein Interactome - PMC [pmc.ncbi.nlm.nih.gov]
- 3. Recent Applications of Diazirines in Chemical Proteomics. | Semantic Scholar [semanticscholar.org]
- 4. Diazirine - Wikipedia [en.wikipedia.org]
- 5. researchgate.net [researchgate.net]
- 6. utoronto.scholaris.ca [utoronto.scholaris.ca]
- 7. Target Identification by Diazirine Photo-Cross-linking and Click Chemistry - PMC [pmc.ncbi.nlm.nih.gov]
- 8. researchgate.net [researchgate.net]
- 9. Applications of Diazirine in Chemical Biology [bldpharm.com]
- 10. researchgate.net [researchgate.net]
- 11. communities.springernature.com [communities.springernature.com]
- 12. PXD048452 - Deciphering Diazirine Reaction Mechanism: through Irradiation Modulation for Residue-Specific Distance Restraints in Protein Photo-Crosslinking - OmicsDI [omicsdi.org]
- To cite this document: BenchChem. [The Role of Diazirines in Identifying Unknown Protein Functions: A Technical Guide]. BenchChem, [2025]. [Online PDF]. Available at: [https://www.benchchem.com/product/b1670410#the-role-of-diazirines-in-identifying-unknown-protein-functions]

Disclaimer & Data Validity:

The information provided in this document is for Research Use Only (RUO) and is strictly not intended for diagnostic or therapeutic procedures. While BenchChem strives to provide accurate protocols, we make no warranties, express or implied, regarding the fitness of this product for every specific experimental setup.

Technical Support: The protocols provided are for reference purposes. Unsure if this reagent suits your experiment? [[Contact our Ph.D. Support Team for a compatibility check](#)]

Need Industrial/Bulk Grade? [Request Custom Synthesis Quote](#)

BenchChem

Our mission is to be the trusted global source of essential and advanced chemicals, empowering scientists and researchers to drive progress in science and industry.

Contact

Address: 3281 E Guasti Rd
Ontario, CA 91761, United States
Phone: (601) 213-4426
Email: info@benchchem.com