

The Role of Autophagy Inducer 3 in Cancer Cell Death: A Technical Guide

Author: BenchChem Technical Support Team. **Date:** December 2025

Compound of Interest

Compound Name: *Autophagy inducer 3*

Cat. No.: *B10857016*

[Get Quote](#)

For Researchers, Scientists, and Drug Development Professionals

This technical guide provides an in-depth overview of **Autophagy inducer 3** and its role in mediating cancer cell death. It covers the core mechanism of action, relevant signaling pathways, quantitative efficacy data, and detailed experimental protocols for its study.

Introduction: The Dichotomous Role of Autophagy in Cancer

Autophagy is a highly conserved catabolic process responsible for the degradation of cellular components through the lysosomal machinery. This process involves the formation of double-membraned vesicles, known as autophagosomes, which engulf cytoplasmic contents and fuse with lysosomes to form autolysosomes, where the cargo is degraded and recycled.[1][2][3] In the context of cancer, autophagy plays a dual role. It can act as a tumor suppressor by eliminating damaged organelles and proteins, thereby maintaining genomic stability.[4] Conversely, in established tumors, autophagy can promote cell survival under stressful conditions such as nutrient deprivation and hypoxia, contributing to therapeutic resistance.[4] However, excessive or sustained autophagy can lead to a form of programmed cell death known as autophagic cell death, which is morphologically distinct from apoptosis. This has led to the exploration of autophagy inducers as a potential therapeutic strategy for cancer.

Autophagy Inducer 3: A Potent Inducer of Lethal Autophagy

Autophagy inducer 3 is a small molecule compound that has been identified as a potent inducer of autophagy. It has been shown to trigger robust autophagic cell death in a variety of cancer cell lines while having minimal cytotoxic effects on normal cells. The lethal autophagy induced by this compound is characterized by the extensive formation of cytoplasmic vacuoles, accumulation of LC3 puncta (a marker for autophagosomes), and the upregulation of key autophagy-related proteins.

Mechanism of Action: Driving Cancer Cells Towards Autophagic Demise

Autophagy inducer 3 exerts its anticancer effects by promoting a non-apoptotic form of cell death. Treatment with **Autophagy inducer 3** leads to a significant increase in cellular granularity due to the formation of autophagic vacuoles. While there is an observed increase in Annexin-V positive cells and some PARP cleavage, the primary mechanism of cell death is attributed to excessive autophagy. This is substantiated by the robust upregulation of essential autophagy markers, including Beclin-1, Atg3, Atg5, and Atg7, upon treatment with the compound.

Quantitative Data on the Efficacy of Autophagy Inducer 3

The anti-proliferative activity of **Autophagy inducer 3** has been evaluated across various cancer cell lines. The following tables summarize the key quantitative data.

Table 1: Anti-proliferative Activity of **Autophagy Inducer 3** in Colon Cancer Cell Lines

Cell Line	IC50 (µM) at 48 hours
COLO-205	2.03
LOVO	3.33
HT-29	4.15
DLD-1	4.46
SW48	3.14
SW-620	1.86
CCD-18Co (Normal)	>10

Data sourced from MyBioSource.

Table 2: Cell Growth Inhibition by **Autophagy Inducer 3** (10 µM) at 48 hours

Cell Line	Cancer Type	Inhibition Rate (%)
MCF-7	Breast	89.28 - 97.66
MDA-MB-231	Breast	89.28 - 97.66
DLD-1	Colon	89.28 - 97.66
HT-29	Colon	89.28 - 97.66
A549	Lung	89.28 - 97.66
NCI-H358	Lung	89.28 - 97.66

Data sourced from MyBioSource and MedchemExpress.

Signaling Pathways in Autophagy-Mediated Cell Death

The induction of autophagy is a tightly regulated process involving a cascade of signaling pathways. The mammalian target of rapamycin (mTOR) is a key negative regulator of autophagy. Downregulation of the PI3K-Akt-mTOR pathway is a common trigger for autophagy induction. **Autophagy inducer 3** likely modulates these pathways to upregulate the expression and activity of the core autophagy machinery.

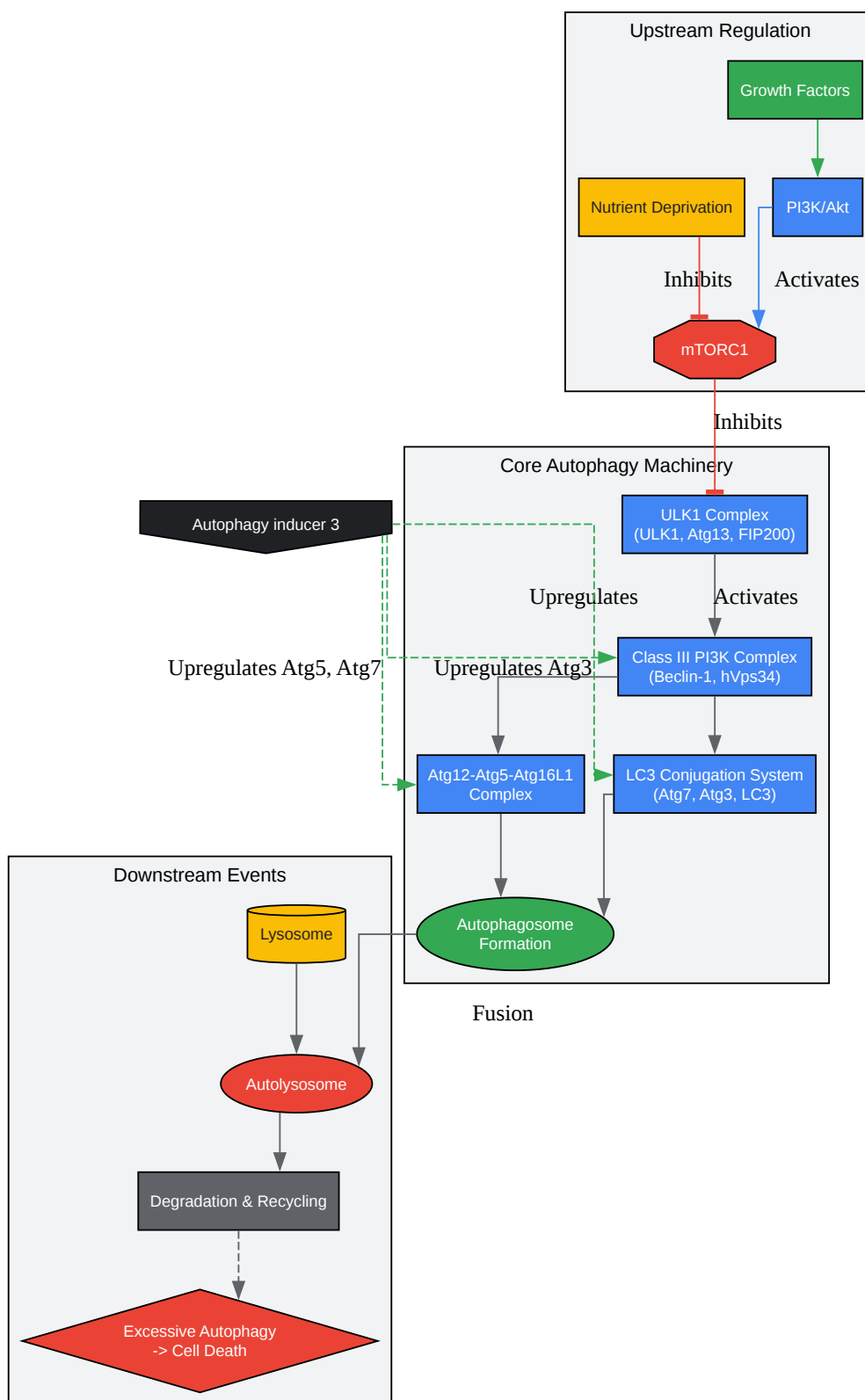

[Click to download full resolution via product page](#)

Figure 1: Simplified Autophagy Signaling Pathway.

Crosstalk Between Autophagy and Apoptosis

Autophagy and apoptosis are interconnected signaling pathways, and extensive crosstalk exists between them. While autophagy often serves as a pro-survival mechanism, its overactivation can trigger cell death. Several key proteins are involved in mediating this balance. For instance, Beclin-1, an essential autophagy protein, interacts with the anti-apoptotic protein Bcl-2. Disruption of this interaction can promote autophagy. Furthermore, caspases, the key effectors of apoptosis, can cleave autophagy-related proteins like Beclin-1 and Atg5, thereby inhibiting autophagy and promoting apoptosis. Conversely, excessive autophagy can lead to the degradation of cellular components to a point that is incompatible with cell survival.

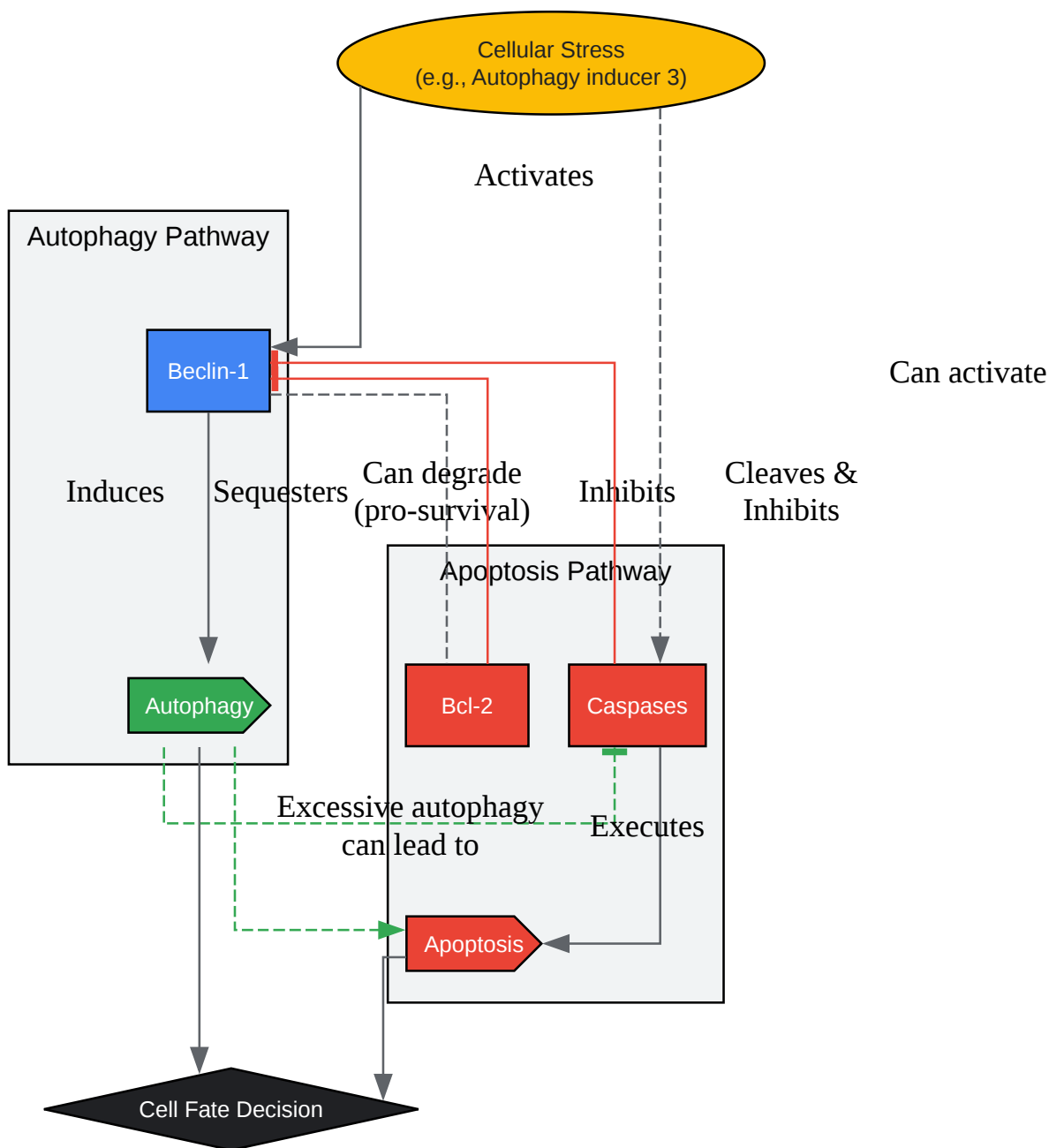

[Click to download full resolution via product page](#)

Figure 2: Crosstalk between Autophagy and Apoptosis.

Experimental Protocols for Studying Autophagy Induction

To evaluate the effects of **Autophagy inducer 3**, a series of in vitro assays are essential.

Cell Proliferation Assay (MTT Assay)

- Principle: Measures cell metabolic activity as an indicator of cell viability.
- Methodology:
 - Seed cancer cells in 96-well plates and allow them to adhere overnight.
 - Treat cells with varying concentrations of **Autophagy inducer 3** (e.g., 0-10 μM) for a specified duration (e.g., 48 hours).
 - Add MTT (3-(4,5-dimethylthiazol-2-yl)-2,5-diphenyltetrazolium bromide) solution to each well and incubate for 2-4 hours to allow the formation of formazan crystals.
 - Solubilize the formazan crystals with a solubilization solution (e.g., DMSO).
 - Measure the absorbance at a specific wavelength (e.g., 570 nm) using a microplate reader.
 - Calculate the percentage of cell viability relative to untreated controls and determine the IC50 value.

Western Blot Analysis of Autophagy Markers

- Principle: Detects and quantifies specific autophagy-related proteins in cell lysates.
- Methodology:
 - Treat cells with **Autophagy inducer 3** (e.g., 7.5 μM) for a set time (e.g., 18 hours).
 - Lyse the cells in RIPA buffer containing protease and phosphatase inhibitors.
 - Determine protein concentration using a BCA or Bradford assay.
 - Separate equal amounts of protein by SDS-PAGE and transfer to a PVDF or nitrocellulose membrane.
 - Block the membrane with 5% non-fat milk or BSA in TBST.

- Incubate the membrane with primary antibodies against LC3, Beclin-1, Atg5, Atg7, and p62/SQSTM1 overnight at 4°C. Also, use an antibody for a loading control (e.g., β -actin or GAPDH).
- Wash the membrane and incubate with HRP-conjugated secondary antibodies.
- Detect the protein bands using an enhanced chemiluminescence (ECL) substrate and an imaging system.
- Quantify band intensities to determine the relative protein expression levels. An increase in the LC3-II/LC3-I ratio and Beclin-1, Atg5, and Atg7 levels, along with a decrease in p62, indicates autophagy induction.

Autophagic Flux Assay

- Principle: Distinguishes between the induction of autophagy and the blockage of autophagosome degradation.
- Methodology:
 - Treat cells with **Autophagy inducer 3** in the presence or absence of a lysosomal inhibitor (e.g., bafilomycin A1 or chloroquine) for the last few hours of the treatment period.
 - Perform Western blot analysis for LC3 and p62 as described above.
 - Interpretation: If **Autophagy inducer 3** truly induces autophagy, the accumulation of LC3-II will be significantly higher in the presence of the lysosomal inhibitor compared to treatment with the inducer alone. This indicates an increased "flux" through the autophagy pathway.

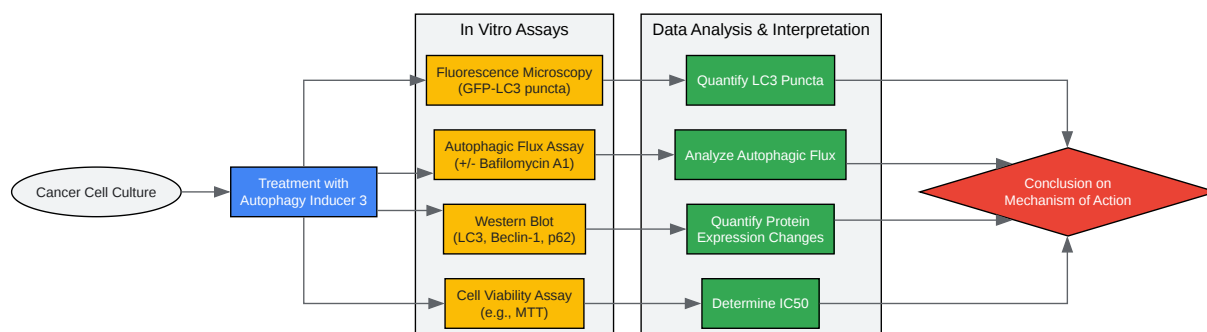

[Click to download full resolution via product page](#)

Figure 3: Experimental Workflow for Evaluating **Autophagy Inducer 3**.

Conclusion

Autophagy inducer 3 represents a promising therapeutic agent that selectively targets cancer cells by inducing lethal autophagy. Its mechanism of action, centered on the upregulation of core autophagy proteins, provides a clear pathway for further investigation and development. The experimental protocols outlined in this guide offer a robust framework for researchers to explore the full potential of this and other autophagy-inducing compounds in the context of cancer therapy. Understanding the intricate balance between the pro-survival and pro-death roles of autophagy is paramount for the successful clinical translation of such targeted therapies.

Need Custom Synthesis?

BenchChem offers custom synthesis for rare earth carbides and specific isotopic labeling.

Email: info@benchchem.com or [Request Quote Online](#).

References

- 1. Autophagy - Wikipedia [en.wikipedia.org]
- 2. mdpi.com [mdpi.com]
- 3. Methods in Mammalian Autophagy Research - PMC [pmc.ncbi.nlm.nih.gov]
- 4. The Role of Autophagy in Cancer: Therapeutic Implications - PMC [pmc.ncbi.nlm.nih.gov]
- To cite this document: BenchChem. [The Role of Autophagy Inducer 3 in Cancer Cell Death: A Technical Guide]. BenchChem, [2025]. [Online PDF]. Available at: [https://www.benchchem.com/product/b10857016#role-of-autophagy-inducer-3-in-cancer-cell-death]

Disclaimer & Data Validity:

The information provided in this document is for Research Use Only (RUO) and is strictly not intended for diagnostic or therapeutic procedures. While BenchChem strives to provide accurate protocols, we make no warranties, express or implied, regarding the fitness of this product for every specific experimental setup.

Technical Support: The protocols provided are for reference purposes. Unsure if this reagent suits your experiment? [[Contact our Ph.D. Support Team for a compatibility check](#)]

Need Industrial/Bulk Grade? [Request Custom Synthesis Quote](#)

BenchChem

Our mission is to be the trusted global source of essential and advanced chemicals, empowering scientists and researchers to drive progress in science and industry.

Contact

Address: 3281 E Guasti Rd

Ontario, CA 91761, United States

Phone: (601) 213-4426

Email: info@benchchem.com