

The Redox Potential of the TMPD/TMPD^{•+} Couple: An In-depth Technical Guide

Author: BenchChem Technical Support Team. **Date:** December 2025

Compound of Interest

Compound Name: *N,N,N',N'*-Tetramethyl-*p*-phenylenediamine

Cat. No.: B3023315

[Get Quote](#)

For Researchers, Scientists, and Drug Development Professionals

This technical guide provides a comprehensive overview of the redox potential of the ***N,N,N',N'*-tetramethyl-*p*-phenylenediamine** (TMPD) and its one-electron oxidized radical cation (TMPD^{•+}), commonly known as Wurster's Blue. This redox couple is a valuable tool in a multitude of research and development applications, from fundamental electrochemical studies to clinical diagnostics and drug discovery.

Introduction to the TMPD/TMPD^{•+} Redox Couple

***N,N,N',N'*-tetramethyl-*p*-phenylenediamine** (TMPD) is a colorless, solid organic compound that readily undergoes a one-electron oxidation to form a stable, intensely colored blue-violet radical cation (TMPD^{•+}). This reversible redox reaction is central to its utility as a redox indicator and mediator in various chemical and biological systems. The standard redox potential of the TMPD/TMPD^{•+} couple is approximately +0.276 V versus the Standard Hydrogen Electrode (SHE), making it a mild oxidizing agent.[1]

The stability of the Wurster's Blue radical cation is a key feature, allowing for its application in systems where a sustained redox-active species is required. However, it is important to note that TMPD can undergo a second one-electron oxidation at a more positive potential to form a dication (TMPD²⁺), which is generally unstable in aqueous solutions.[2][3] Understanding the factors that influence the redox potential of the TMPD/TMPD^{•+} couple is critical for its effective application.

Quantitative Data on the Redox Potential of the TMPD/TMPD^{•+} Couple

The redox potential of the TMPD/TMPD^{•+} couple is influenced by several factors, including the solvent, the reference electrode used for measurement, and to a lesser extent, pH and temperature. The following tables summarize key quantitative data from various studies.

Solvent	Supporting Electrolyte	Reference Electrode	E° (V)	Notes
Aqueous (pH 7.4 PBS)	-	Ag/AgCl	-0.0	The oxidation process occurs at low potentials. [4]
Acetonitrile	0.1 M TBAP	Not specified	-	Cyclic voltammogram provided in the source. [5]
Ionic Liquid ([C2mim][N(Tf)2])	20 mM TMPD + BF4 ⁻	Ag quasi-reference	-0.1	First oxidation to the radical cation. [5]
Propylene Carbonate	1.0 M LiBF4	Li/Li ⁺	3.2	First one-electron oxidation. [6]
Propylene Carbonate	1.0 M LiBF4	Li/Li ⁺	3.8	Second one-electron oxidation to the dication. [6]

Table 1: Redox Potential of the TMPD/TMPD^{•+} Couple in Various Solvents. E° represents the formal potential.

Factor	Condition	Effect on Redox Potential	Reference
pH	Decrease (more acidic)	Generally leads to an increase in redox potential for reactions involving protons. A decrease of one pH unit can increase the redox potential by 59 mV at 25°C for a 1-proton, 1-electron process. ^[7] While specific quantitative data for TMPD across a wide pH range is not readily available in the literature, cyclic voltammograms of similar compounds show a negative shift in oxidation potential with increasing pH, indicating that the oxidation is easier at higher pH. ^[8]	^[7] ^[8]
Temperature	Increase	The effect is generally linear and can be described by the temperature coefficient (dE°/dT). For many redox couples, an increase in temperature can lead to either an increase or decrease in the redox potential,	^[9] ^[10]

depending on the entropy change of the reaction.[9][10]

Specific quantitative data for the temperature dependence of the TMPD/TMPD^{•+} redox potential is not extensively documented in the reviewed literature.

Table 2: Influence of pH and Temperature on the Redox Potential of the TMPD/TMPD^{•+} Couple.

Experimental Protocols

Determination of Redox Potential by Cyclic Voltammetry

Cyclic voltammetry (CV) is a powerful electrochemical technique to characterize the redox properties of the TMPD/TMPD^{•+} couple.

Objective: To determine the formal redox potential (E°) of the TMPD/TMPD^{•+} couple.

Materials:

- Potentiostat
- Three-electrode cell:
 - Working electrode (e.g., glassy carbon, platinum, or gold)
 - Reference electrode (e.g., Ag/AgCl or Saturated Calomel Electrode - SCE)
 - Counter electrode (e.g., platinum wire)
- **N,N,N',N'-tetramethyl-p-phenylenediamine (TMPD)**

- Anhydrous solvent (e.g., acetonitrile, dichloromethane)
- Supporting electrolyte (e.g., 0.1 M tetrabutylammonium hexafluorophosphate - TBAPF6)
- Inert gas (e.g., argon or nitrogen) for deaeration

Procedure:

- **Solution Preparation:** Prepare a solution of TMPD (e.g., 1-5 mM) in the chosen solvent containing the supporting electrolyte.
- **Deaeration:** Purge the solution with an inert gas for at least 15-20 minutes to remove dissolved oxygen, which can interfere with the measurement. Maintain a blanket of inert gas over the solution during the experiment.
- **Electrode Preparation:** Polish the working electrode with alumina slurry, rinse thoroughly with deionized water and the solvent, and dry it before use.
- **Cell Assembly:** Assemble the three-electrode cell with the prepared solution.
- **Cyclic Voltammetry Scan:**
 - Set the potential window to scan from an initial potential where no reaction occurs to a potential sufficiently positive to oxidize TMPD, and then reverse the scan back to the initial potential. A typical range could be from -0.2 V to +0.8 V vs. Ag/AgCl.
 - Set the scan rate (e.g., 100 mV/s).
 - Perform the scan and record the resulting voltammogram (current vs. potential).
- **Data Analysis:**
 - Identify the anodic peak potential (E_{pa}) and the cathodic peak potential (E_{pc}) from the voltammogram.
 - Calculate the formal redox potential (E°) as the average of the peak potentials: $E^{\circ} = (E_{pa} + E_{pc}) / 2$.

- The peak separation ($\Delta E_p = E_{pa} - E_{pc}$) should be close to $59/n$ mV (where n is the number of electrons, which is 1 for the TMPD/TMPD^{•+} couple) for a reversible system at 25°C.

Oxidase Test for Cytochrome c Oxidase Activity

TMPD is a key reagent in the oxidase test, used to identify bacteria containing cytochrome c oxidase.

Objective: To determine the presence of cytochrome c oxidase in a bacterial culture.

Materials:

- Bacterial culture to be tested
- Oxidase test reagent (1% **N,N,N',N'**-tetramethyl-**p**-phenylenediamine dihydrochloride in sterile distilled water; prepare fresh or use commercial reagents)
- Filter paper (Whatman No. 1)
- Sterile applicator stick (e.g., wooden stick or platinum loop)
- Petri dish

Procedure (Filter Paper Method):

- Place a piece of filter paper in a clean petri dish.
- Add 2-3 drops of the oxidase reagent to the center of the filter paper.
- Using a sterile applicator stick, pick a well-isolated colony from the bacterial culture.
- Smear the colony onto the reagent-impregnated filter paper.
- Observe for a color change within 10-30 seconds.

Interpretation:

- Positive Result: A rapid change in color to blue or deep purple indicates the presence of cytochrome c oxidase.[4][11]
- Negative Result: The absence of a color change or a very slow, faint color change after 30 seconds is a negative result.[5]

Visualizations: Pathways and Workflows

Electron Transfer Pathway in the Oxidase Test

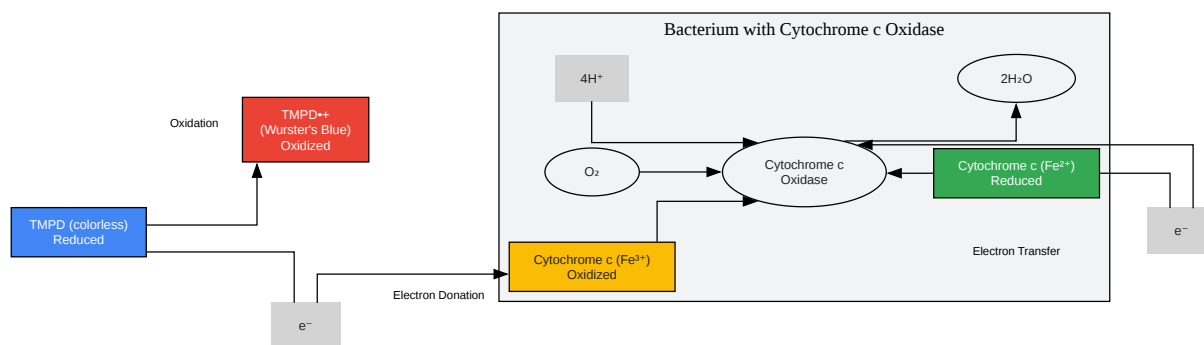

[Click to download full resolution via product page](#)

Caption: Electron transfer from TMPD to cytochrome c, catalyzed by cytochrome c oxidase.

Experimental Workflow for Cyclic Voltammetry

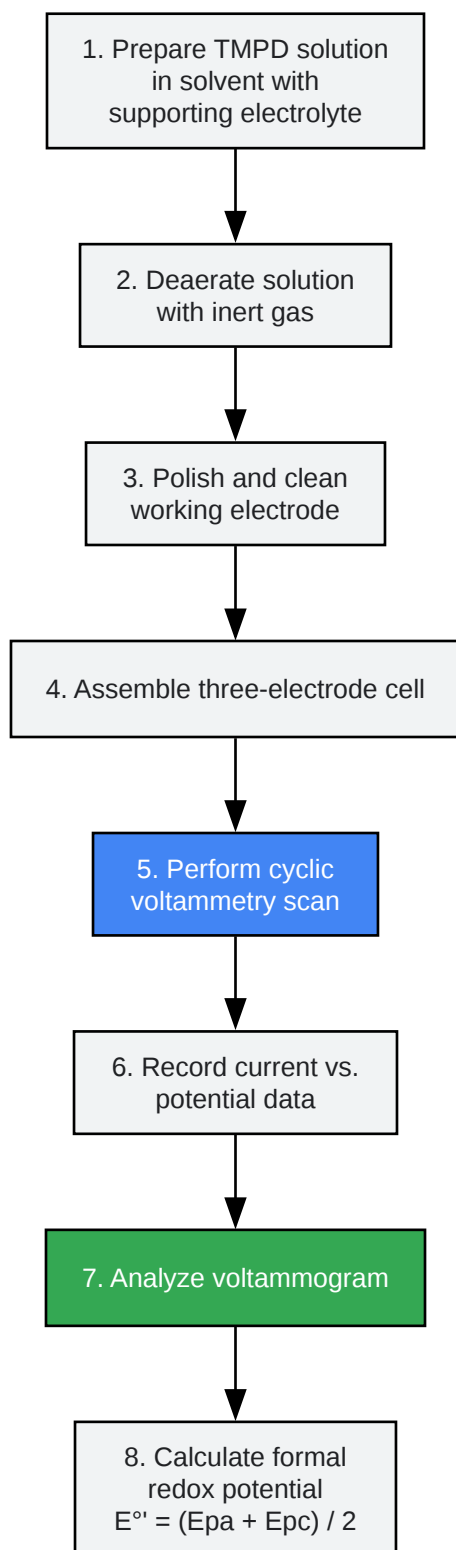

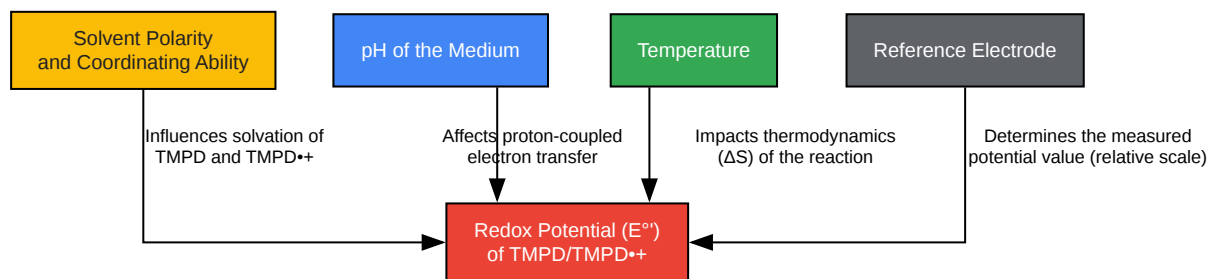

[Click to download full resolution via product page](#)

Need Custom Synthesis?

BenchChem offers custom synthesis for rare earth carbides and specific isotopic labeling.

Email: info@benchchem.com or [Request Quote Online](#).

References

- 1. asm.org [asm.org]
- 2. Oxidase Test [asm.org]
- 3. Table of standard reduction potentials for half-reactions important in biochemistry - Wikipedia [en.wikipedia.org]
- 4. researchgate.net [researchgate.net]
- 5. researchgate.net [researchgate.net]
- 6. researchgate.net [researchgate.net]
- 7. public-pages-files-2025.frontiersin.org [public-pages-files-2025.frontiersin.org]
- 8. researchgate.net [researchgate.net]
- 9. researchgate.net [researchgate.net]
- 10. srd.nist.gov [srd.nist.gov]
- 11. Oxidase test - Wikipedia [en.wikipedia.org]
- To cite this document: BenchChem. [The Redox Potential of the TMPD/TMPD⁺⁺ Couple: An In-depth Technical Guide]. BenchChem, [2025]. [Online PDF]. Available at:

[<https://www.benchchem.com/product/b3023315#understanding-the-redox-potential-of-the-tmpd-tmpd-couple>]

Disclaimer & Data Validity:

The information provided in this document is for Research Use Only (RUO) and is strictly not intended for diagnostic or therapeutic procedures. While BenchChem strives to provide accurate protocols, we make no warranties, express or implied, regarding the fitness of this product for every specific experimental setup.

Technical Support: The protocols provided are for reference purposes. Unsure if this reagent suits your experiment? [[Contact our Ph.D. Support Team for a compatibility check](#)]

Need Industrial/Bulk Grade? [Request Custom Synthesis Quote](#)

BenchChem

Our mission is to be the trusted global source of essential and advanced chemicals, empowering scientists and researchers to drive progress in science and industry.

Contact

Address: 3281 E Guasti Rd
Ontario, CA 91761, United States
Phone: (601) 213-4426
Email: info@benchchem.com