

The Neuroprotective Potential of PM226: A Technical Guide

Author: BenchChem Technical Support Team. **Date:** December 2025

Compound of Interest

Compound Name: PM226

Cat. No.: B2447522

[Get Quote](#)

For Researchers, Scientists, and Drug Development Professionals

Abstract

PM226, a novel chromenoisoxazole derivative, has emerged as a promising neuroprotective agent with a distinct mechanism of action. This technical guide provides an in-depth overview of the preclinical data supporting the neuroprotective effects of **PM226**. It details the compound's selective agonist activity at the cannabinoid CB2 receptor, its anti-inflammatory properties, and its efficacy in both in vitro and in vivo models of neuronal damage. This document aims to equip researchers and drug development professionals with a comprehensive understanding of **PM226**'s pharmacological profile, experimental validation, and the underlying signaling pathways governing its neuroprotective capacity.

Introduction

Neurodegenerative diseases represent a significant and growing global health challenge, characterized by the progressive loss of neuronal structure and function. The development of effective disease-modifying therapies remains a critical unmet need. Cannabinoid receptors, particularly the CB2 receptor, have garnered considerable interest as a therapeutic target due to their role in modulating neuroinflammation and neuronal survival, without the psychoactive effects associated with CB1 receptor activation.^[1] **PM226** is a selective CB2 receptor agonist that has demonstrated a promising neuroprotective profile, suggesting its potential as a therapeutic candidate for neurodegenerative disorders.^[1]

Pharmacological Profile of PM226

PM226 is a chromenoisoxazole compound characterized by its high selectivity for the CB2 receptor.[1] In silico analysis predicts good pharmacokinetic properties and the ability to cross the blood-brain barrier, a crucial attribute for a centrally acting neuroprotective agent.[1]

Quantitative Pharmacological Data

The binding affinity and functional activity of **PM226** at cannabinoid receptors have been quantified, highlighting its selectivity for the CB2 receptor.

Parameter	Value	Receptor	Assay Type
Ki	>40000 nM	CB1	Binding Affinity
EC50	38.67 ± 6.70 nM	CB2	GTPyS Binding (Agonist Activity)

Table 1: Binding Affinity and Functional Activity of **PM226**. [1]

In Vitro Neuroprotective Effects

The neuroprotective properties of **PM226** have been investigated in vitro, primarily focusing on its ability to mitigate microglial-mediated neurotoxicity.

Experimental Model: Microglial-Mediated Neurotoxicity

An in vitro model utilizing lipopolysaccharide (LPS)-stimulated BV2 microglial cells was employed to generate a pro-inflammatory environment. Conditioned media from these activated microglia were then applied to M213-2O neuronal cells to assess neurotoxicity.[1]

Experimental Protocol: Conditioned Media Neurotoxicity Assay

- **BV2 Microglial Cell Culture:** BV2 cells were cultured in appropriate media.
- **LPS Stimulation:** BV2 cells were stimulated with LPS in the absence or presence of varying concentrations of **PM226**.

- **Conditioned Media Collection:** After a specified incubation period, the conditioned media from the BV2 cultures were collected.
- **Neuronal Cell Culture:** M213-2O neuronal cells were cultured separately.
- **Application of Conditioned Media:** The collected conditioned media were added to the M213-2O neuronal cell cultures.
- **Cell Viability Assessment:** Neuronal cell viability was quantified using the MTT assay.
- **CB2 Receptor Antagonism:** To confirm the mechanism of action, experiments were repeated with the co-incubation of the CB2 antagonist SR144528.[1]

Results

Exposure of neuronal cells to conditioned media from LPS-stimulated microglia resulted in a significant reduction in cell viability.[1] The addition of **PM226** to the microglial cultures attenuated this neurotoxic effect in a dose-dependent manner.[1] This protective effect was reversed by the CB2 antagonist SR144528, confirming the involvement of the CB2 receptor.[1] Notably, direct application of **PM226** to neuronal cultures (without the conditioned media) had no effect on viability, indicating that the neuroprotection is mediated through its action on microglial cells.[1]

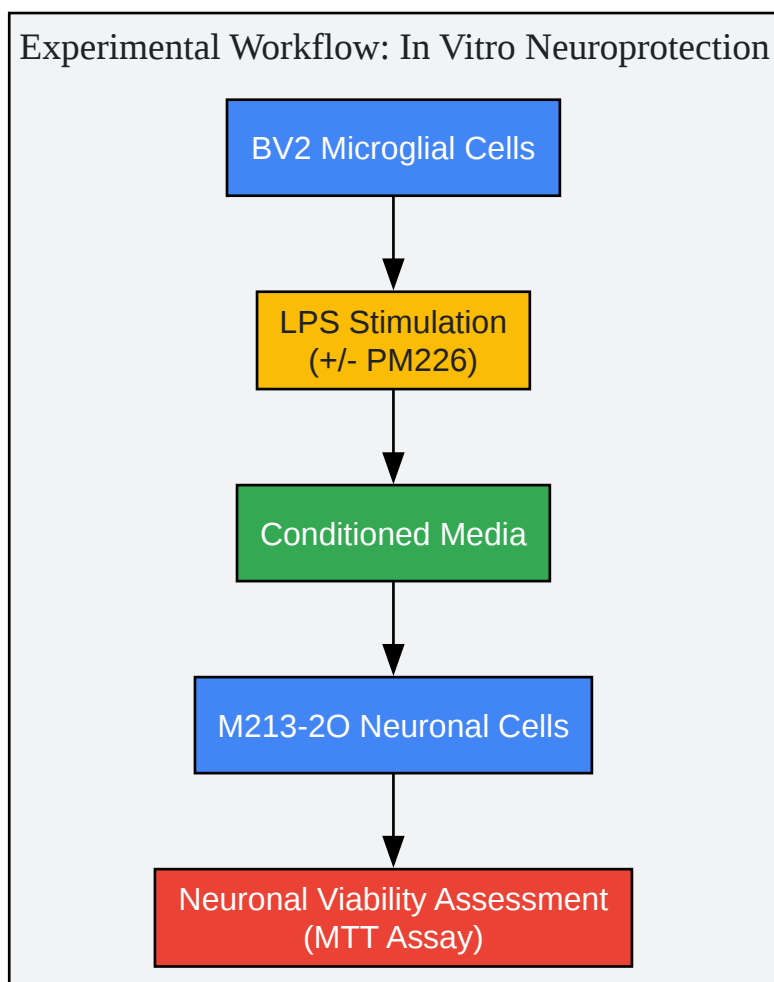

[Click to download full resolution via product page](#)

In Vitro Neuroprotection Experimental Workflow

In Vivo Neuroprotective Effects

The neuroprotective efficacy of **PM226** was further evaluated in an in vivo model of mitochondrial damage.

Experimental Model: Malonate-Induced Striatal Lesion

Intrastratial injection of malonate, a mitochondrial complex II inhibitor, was used to induce a localized lesion in the rat brain, mimicking aspects of neurodegenerative processes involving mitochondrial dysfunction.[1]

Experimental Protocol: Malonate-Induced Lesion Model

- Animal Model: Rats were used for this study.
- Malonate Administration: Malonate was administered via intrastriatal injection.
- **PM226** Treatment: Animals were treated with **PM226**.
- CB2 Receptor Antagonism: A separate group of animals received the CB2 antagonist AM630 in conjunction with **PM226** to verify the mechanism.[1]
- Lesion Volume Assessment: Magnetic Resonance Imaging (MRI) was used to measure the volume of the striatal lesion.
- Histopathological Evaluation: Post-mortem analysis of striatal sections included:
 - Nissl Staining: To assess neuronal survival.
 - Iba-1 Immunostaining: To evaluate microglial activation.
 - TUNEL Assay: To detect apoptotic cell death.[1]

Results

Administration of **PM226** significantly decreased the volume of the striatal lesion induced by malonate, as observed through MRI analysis.[1] Histopathological examination confirmed these findings, showing reduced neuronal loss, decreased microglial activation (Iba-1 staining), and fewer apoptotic cells (TUNEL assay) in **PM226**-treated animals.[1] The beneficial effects of **PM226** were reversed by the co-administration of the CB2 antagonist AM630, further substantiating that the neuroprotection is mediated by CB2 receptor activation.[1]

Mechanism of Action and Signaling Pathway

The neuroprotective effects of **PM226** are primarily attributed to its selective activation of the CB2 receptor, which is predominantly expressed on immune cells, including microglia in the central nervous system.

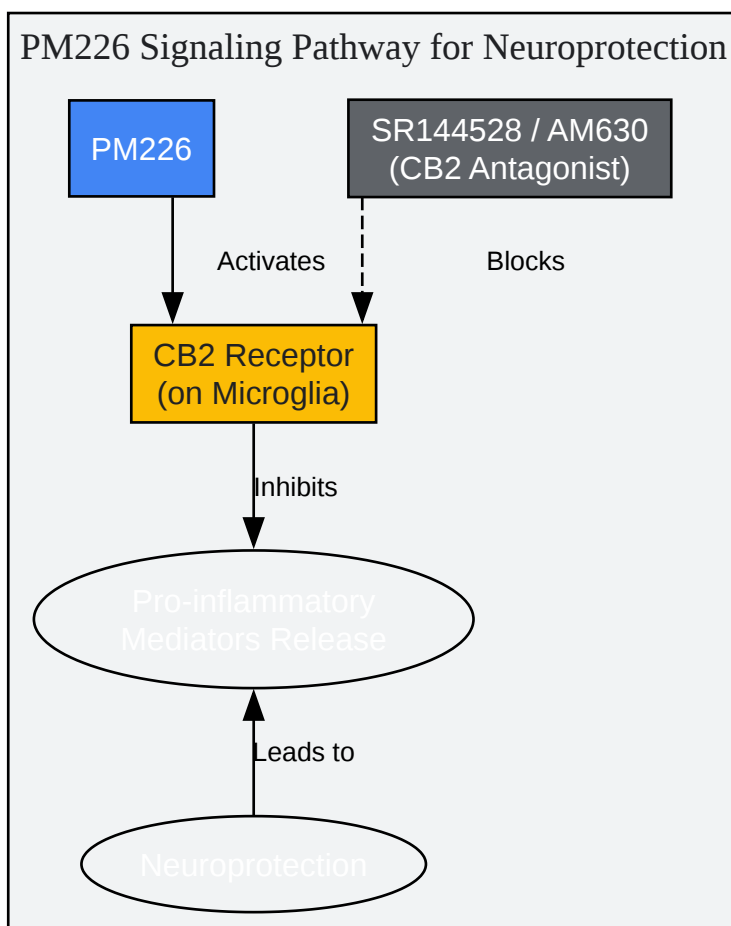

[Click to download full resolution via product page](#)

PM226 Signaling Pathway

Activation of the CB2 receptor on microglia by **PM226** is hypothesized to suppress the release of pro-inflammatory and neurotoxic factors that are typically upregulated in response to stimuli like LPS. This anti-inflammatory action on microglia indirectly protects neurons from damage. The reversal of **PM226**'s neuroprotective effects by CB2 antagonists in both in vitro and in vivo models provides strong evidence for this receptor-mediated pathway.^[1]

Conclusion and Future Directions

PM226 has demonstrated significant neuroprotective potential through its selective activation of the CB2 receptor. Its ability to mitigate microglial-mediated inflammation and subsequent neuronal damage in preclinical models highlights its promise as a therapeutic candidate for neurodegenerative diseases. The data presented in this technical guide underscore the

importance of the CB2 receptor as a therapeutic target and position **PM226** as a valuable tool for further investigation.

Future research should focus on:

- Elucidating the downstream intracellular signaling cascades following CB2 receptor activation by **PM226**.
- Evaluating the efficacy of **PM226** in a broader range of neurodegenerative disease models.
- Conducting comprehensive pharmacokinetic and toxicological studies to support its potential clinical development.

This in-depth technical guide provides a solid foundation for researchers, scientists, and drug development professionals to understand and explore the therapeutic potential of **PM226** in the context of neuroprotection.

Need Custom Synthesis?

BenchChem offers custom synthesis for rare earth carbides and specific isotopic labeling.

Email: info@benchchem.com or [Request Quote Online](#).

References

- 1. Biological characterization of PM226, a chromenoisoxazole, as a selective CB2 receptor agonist with neuroprotective profile - PubMed [pubmed.ncbi.nlm.nih.gov]
- To cite this document: BenchChem. [The Neuroprotective Potential of PM226: A Technical Guide]. BenchChem, [2025]. [Online PDF]. Available at: [https://www.benchchem.com/product/b2447522#neuroprotective-effects-of-pm226]

Disclaimer & Data Validity:

The information provided in this document is for Research Use Only (RUO) and is strictly not intended for diagnostic or therapeutic procedures. While BenchChem strives to provide accurate protocols, we make no warranties, express or implied, regarding the fitness of this product for every specific experimental setup.

Technical Support: The protocols provided are for reference purposes. Unsure if this reagent suits your experiment? [[Contact our Ph.D. Support Team for a compatibility check](#)]

Need Industrial/Bulk Grade? [Request Custom Synthesis Quote](#)

BenchChem

Our mission is to be the trusted global source of essential and advanced chemicals, empowering scientists and researchers to drive progress in science and industry.

Contact

Address: 3281 E Guasti Rd
Ontario, CA 91761, United States
Phone: (601) 213-4426
Email: info@benchchem.com