

The Industrial Potential of 2-Methyl-1-phenylbutan-2-ol: A Technical Guide

Author: BenchChem Technical Support Team. **Date:** December 2025

Compound of Interest

Compound Name: 2-Methyl-1-phenylbutan-2-ol

Cat. No.: B1584244

[Get Quote](#)

For Researchers, Scientists, and Drug Development Professionals

Abstract

2-Methyl-1-phenylbutan-2-ol, a tertiary aryl alkyl alcohol, presents significant opportunities across various industrial sectors. While direct, large-scale industrial use is not extensively documented, its structural characteristics and those of its close isomers strongly suggest high potential in the fragrance and pharmaceutical industries. Its pleasant aromatic properties make it a candidate for use in perfumery and cosmetics. Furthermore, its role as a versatile chemical intermediate is of considerable interest, particularly in the synthesis of complex chiral molecules which are foundational in modern drug development. This guide provides a comprehensive overview of the chemical and physical properties, synthesis protocols, potential industrial applications, and safety considerations for **2-Methyl-1-phenylbutan-2-ol**, serving as a foundational resource for researchers and developers.

Physicochemical Properties

A thorough understanding of the physicochemical properties of **2-Methyl-1-phenylbutan-2-ol** is essential for its application in industrial processes. While some experimental data is limited for this specific isomer, a combination of computed data and information from closely related isomers provides a reliable profile.

Property	Value	Data Type	Source(s)
Molecular Formula	C ₁₁ H ₁₆ O	-	--INVALID-LINK--[1]
Molecular Weight	164.24 g/mol	Computed	--INVALID-LINK--[2]
CAS Number	772-46-3	-	--INVALID-LINK--[1]
Appearance	Not specified; likely a liquid or low-melting solid	Inferred	-
Boiling Point	Not available	-	--INVALID-LINK--[1]
Melting Point	Not available	-	--INVALID-LINK--[1]
Density	Not available	-	--INVALID-LINK--[1]
LogP (Octanol-Water Partition Coefficient)	2.3901	Computed	--INVALID-LINK--[1]
Topological Polar Surface Area (TPSA)	20.23 Å ²	Computed	--INVALID-LINK--[1]
Hydrogen Bond Donors	1	Computed	--INVALID-LINK--[1]
Hydrogen Bond Acceptors	1	Computed	--INVALID-LINK--[1]
Rotatable Bonds	3	Computed	--INVALID-LINK--[1]

Synthesis of 2-Methyl-1-phenylbutan-2-ol

The primary and most efficient method for the laboratory and potential industrial-scale synthesis of **2-Methyl-1-phenylbutan-2-ol** is through a Grignard reaction. This classic carbon-carbon bond-forming reaction offers high yields and selectivity.

Grignard Reaction Protocol

This protocol outlines the synthesis of **2-Methyl-1-phenylbutan-2-ol** from benzylmagnesium halide and 2-butanone.

Materials:

- Magnesium turnings
- Benzyl bromide (or chloride)
- Anhydrous diethyl ether or tetrahydrofuran (THF)
- Iodine crystal (for initiation)
- 2-Butanone
- Saturated aqueous ammonium chloride solution
- Anhydrous magnesium sulfate
- Standard laboratory glassware for inert atmosphere reactions

Procedure:

- Preparation of the Grignard Reagent: In a flame-dried, three-necked flask equipped with a dropping funnel, condenser, and magnetic stirrer, under an inert atmosphere (e.g., nitrogen or argon), place the magnesium turnings. Add a small crystal of iodine to activate the magnesium surface.
- A solution of benzyl bromide in anhydrous diethyl ether is added dropwise from the dropping funnel. The reaction is exothermic and the rate of addition should be controlled to maintain a gentle reflux.
- After the addition is complete and the magnesium has been consumed, the resulting Grignard reagent (benzylmagnesium bromide) is cooled in an ice bath.
- Reaction with Ketone: A solution of 2-butanone in anhydrous diethyl ether is added dropwise to the cooled Grignard reagent with vigorous stirring. The temperature should be maintained below 10°C.
- Work-up: After the addition is complete, the reaction mixture is allowed to warm to room temperature and stirred for an additional 1-2 hours.

- The reaction is then quenched by the slow, dropwise addition of a saturated aqueous ammonium chloride solution.
- The organic layer is separated, and the aqueous layer is extracted with diethyl ether.
- The combined organic layers are washed with brine, dried over anhydrous magnesium sulfate, filtered, and the solvent is removed under reduced pressure to yield the crude product.
- Purification: The crude **2-Methyl-1-phenylbutan-2-ol** can be purified by vacuum distillation or column chromatography.

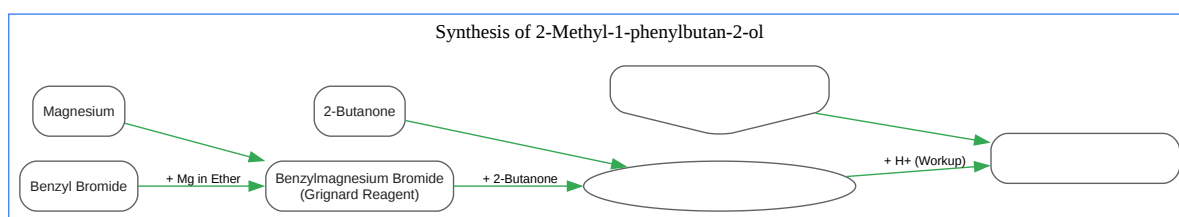

[Click to download full resolution via product page](#)

Figure 1: Grignard reaction workflow for the synthesis of **2-Methyl-1-phenylbutan-2-ol**.

Potential Industrial Applications

Fragrance and Flavor Industry

Aryl alkyl alcohols are a well-established class of compounds in the fragrance industry. The structural isomer, 2-methyl-4-phenyl-2-butanol, is known for its floral aroma, reminiscent of lily of the valley, and is used in various cosmetic and cleaning products. Given the structural similarity, **2-Methyl-1-phenylbutan-2-ol** is highly likely to possess desirable olfactory properties, making it a strong candidate for use as a fragrance ingredient in perfumes, soaps, lotions, and other consumer products. Its tertiary alcohol group provides stability, which is a desirable trait for fragrance longevity.

Pharmaceutical Intermediate

The structure of **2-Methyl-1-phenylbutan-2-ol** makes it a valuable chiral building block in organic synthesis, particularly for the pharmaceutical industry. It can serve as a precursor for the synthesis of more complex molecules with potential biological activity. For instance, it can be a starting material for the synthesis of chiral amino alcohols, which are key structural motifs in many pharmaceuticals, including some antiviral and anti-inflammatory drugs. The tertiary alcohol can be converted to other functional groups, and the phenyl ring can be modified to create a library of derivatives for drug discovery screening.

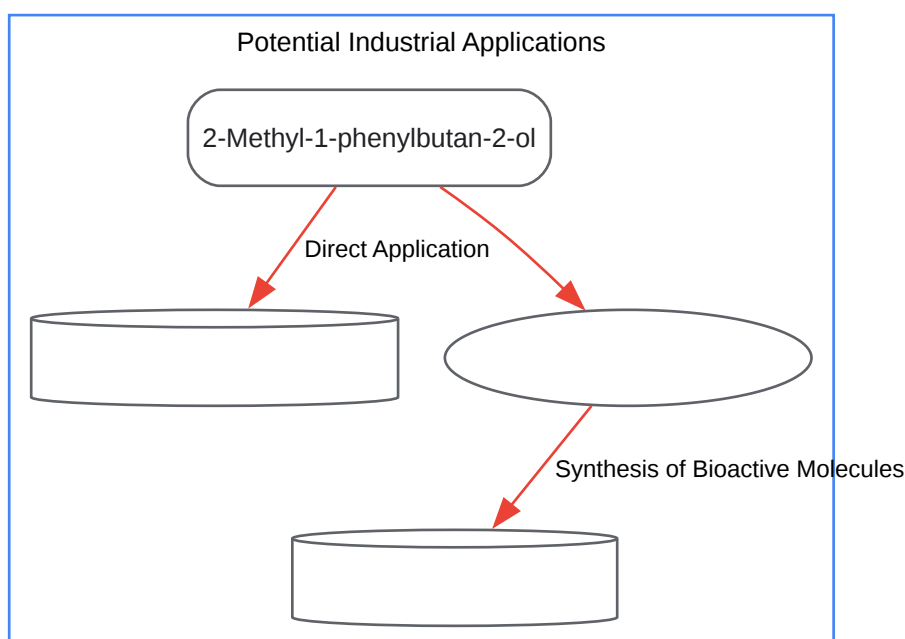

[Click to download full resolution via product page](#)

Figure 2: Logical relationship of potential industrial applications.

Biological Activity and Mechanism of Action

While specific studies on the biological activity of **2-Methyl-1-phenylbutan-2-ol** are limited, the broader class of aryl alkyl alcohols has been shown to exhibit various biological effects, including antimicrobial and anti-inflammatory properties. The mechanism of action for some aryl alcohols involves interaction with enzymes such as aryl-alcohol oxidases (AAOs). These enzymes catalyze the oxidation of aryl alcohols, a process that can have implications in various biological pathways. The potential for **2-Methyl-1-phenylbutan-2-ol** and its derivatives to

modulate such enzymatic activities warrants further investigation for drug development purposes.

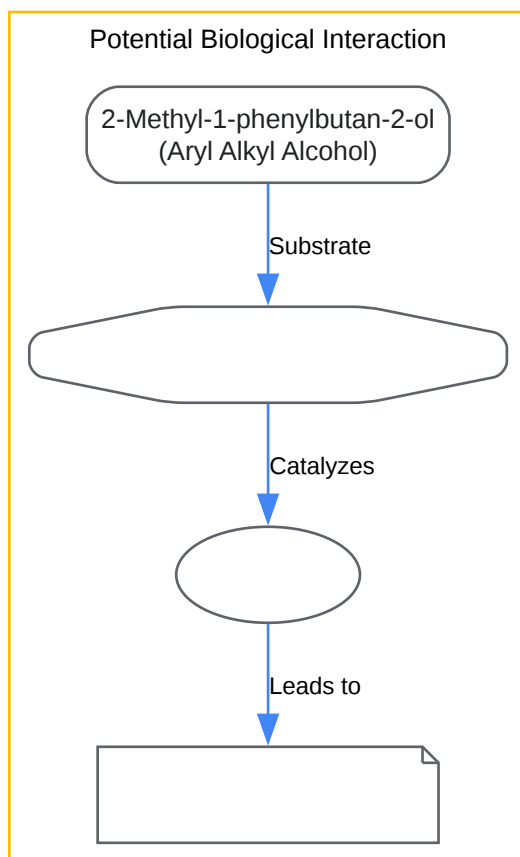

[Click to download full resolution via product page](#)

Figure 3: Hypothetical interaction with Aryl-Alcohol Oxidase.

Analytical Methods

The purity and identity of **2-Methyl-1-phenylbutan-2-ol** can be determined using standard analytical techniques.

Gas Chromatography-Mass Spectrometry (GC-MS)

GC-MS is a powerful technique for the separation and identification of volatile and semi-volatile compounds like **2-Methyl-1-phenylbutan-2-ol**.

General Protocol:

- Sample Preparation: Dissolve a small amount of the sample in a volatile organic solvent (e.g., dichloromethane or ethyl acetate).
- GC Conditions:
 - Column: A non-polar capillary column (e.g., DB-5ms or HP-5ms).
 - Injector Temperature: 250 °C.
 - Oven Program: Start at a low temperature (e.g., 50 °C), hold for a few minutes, then ramp up to a higher temperature (e.g., 280 °C).
 - Carrier Gas: Helium at a constant flow rate.
- MS Conditions:
 - Ionization Mode: Electron Ionization (EI) at 70 eV.
 - Mass Range: Scan from m/z 40 to 400.

The resulting mass spectrum can be compared to spectral libraries for identification.

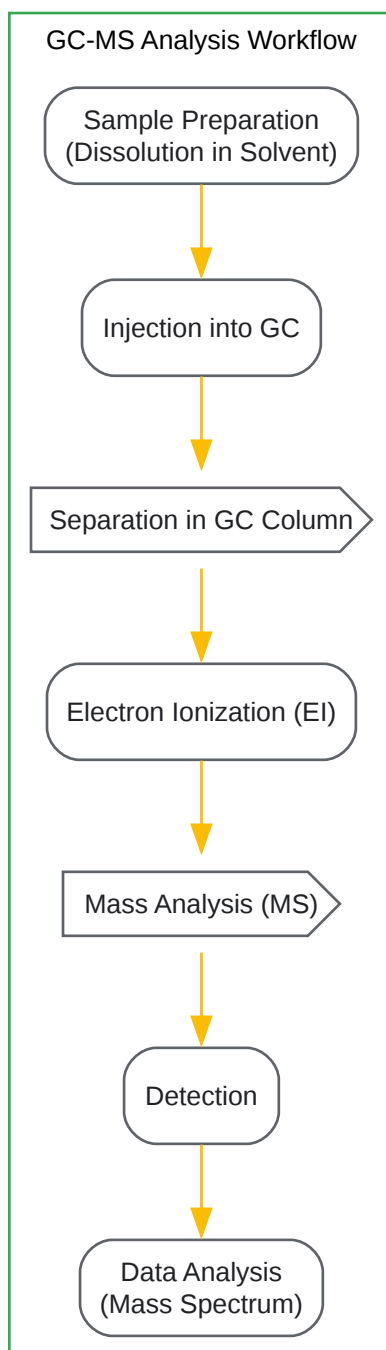

[Click to download full resolution via product page](#)

Figure 4: General workflow for GC-MS analysis.

Safety and Handling

While a specific Material Safety Data Sheet (MSDS) for **2-Methyl-1-phenylbutan-2-ol** is not readily available, data from its isomers and related aryl alkyl alcohols can provide guidance on

its safe handling.

General Safety Precautions:

- Eye Contact: Likely to cause eye irritation. In case of contact, rinse immediately with plenty of water and seek medical advice.[3][4]
- Skin Contact: May cause skin irritation. Wear suitable protective gloves and clothing.[5]
- Inhalation: May cause respiratory tract irritation. Use in a well-ventilated area or with appropriate respiratory protection.[5]
- Ingestion: Harmful if swallowed. Do not induce vomiting. Seek immediate medical attention. [5]
- Flammability: Likely to be a flammable liquid. Keep away from heat, sparks, and open flames.[5]

Personal Protective Equipment (PPE):

- Safety glasses or goggles
- Chemical-resistant gloves (e.g., nitrile)
- Laboratory coat
- Use in a chemical fume hood

Conclusion

2-Methyl-1-phenylbutan-2-ol is a promising aryl alkyl alcohol with significant potential for industrial applications. Its likely pleasant aromatic properties make it a strong candidate for the fragrance and flavor industry. Furthermore, its utility as a versatile chemical intermediate opens up avenues for the synthesis of novel and potentially bioactive molecules for the pharmaceutical sector. Further research is warranted to fully elucidate its specific industrial applications, biological activities, and to establish a comprehensive safety profile. This technical guide provides a solid foundation for researchers and drug development professionals to explore and unlock the full potential of this intriguing molecule.

Need Custom Synthesis?

BenchChem offers custom synthesis for rare earth carbides and specific isotopic labeling.

Email: info@benchchem.com or [Request Quote Online](#).

References

- 1. chemscene.com [chemscene.com]
- 2. 2-Methyl-1-phenyl-2-butanol 98.0+%, TCI America™ | Fisher Scientific [fishersci.ca]
- 3. aurochemicals.com [aurochemicals.com]
- 4. echemi.com [echemi.com]
- 5. bg.cpachem.com [bg.cpachem.com]
- To cite this document: BenchChem. [The Industrial Potential of 2-Methyl-1-phenylbutan-2-ol: A Technical Guide]. BenchChem, [2025]. [Online PDF]. Available at: [https://www.benchchem.com/product/b1584244#potential-industrial-applications-of-2-methyl-1-phenylbutan-2-ol]

Disclaimer & Data Validity:

The information provided in this document is for Research Use Only (RUO) and is strictly not intended for diagnostic or therapeutic procedures. While BenchChem strives to provide accurate protocols, we make no warranties, express or implied, regarding the fitness of this product for every specific experimental setup.

Technical Support: The protocols provided are for reference purposes. Unsure if this reagent suits your experiment? [[Contact our Ph.D. Support Team for a compatibility check](#)]

Need Industrial/Bulk Grade? [Request Custom Synthesis Quote](#)

BenchChem

Our mission is to be the trusted global source of essential and advanced chemicals, empowering scientists and researchers to drive progress in science and industry.

Contact

Address: 3281 E Guasti Rd

Ontario, CA 91761, United States

Phone: (601) 213-4426

Email: info@benchchem.com