

The Emerging Roles of 5-Methoxycytidine: An Epitranscriptomic Regulator

Author: BenchChem Technical Support Team. **Date:** December 2025

Compound of Interest

Compound Name: 5-Methoxy cytidine

Cat. No.: B12387523

[Get Quote](#)

A Technical Guide for Researchers and Drug Development Professionals

November 27, 2025

Abstract

5-Methoxycytidine (5-moC) and its more prevalent precursor, 5-methylcytidine (m5C), are critical post-transcriptional RNA modifications implicated in a myriad of biological processes. This technical guide provides an in-depth exploration of the biological significance of 5-methylcytidine, its enzymatic regulation, and its impact on RNA function, with a particular focus on its relevance to researchers, scientists, and drug development professionals. We delve into the intricate roles of m5C in modulating mRNA stability, nuclear export, and translation, and its crucial functions within tRNA and rRNA. Furthermore, this guide details the methodologies for detecting and quantifying m5C, and presents the current understanding of its involvement in human diseases, including cancer and neurological disorders, highlighting its potential as a therapeutic target.

Introduction to 5-Methylcytidine (m5C)

5-methylcytosine (m5C) is a post-transcriptional modification found in various RNA molecules, including transfer RNAs (tRNAs), ribosomal RNAs (rRNAs), messenger RNAs (mRNAs), and various non-coding RNAs.[1][2] This modification, where a methyl group is added to the C5 position of a cytosine residue, is a dynamic and reversible process, suggesting its role as a key

player in the epitranscriptomic regulation of gene expression.[2] The enzymes responsible for depositing this mark are known as "writers" (methyltransferases), while "erasers" (demethylases) remove it, and "readers" (binding proteins) recognize m5C to elicit a functional response.[2]

Biological Roles of 5-Methylcytidine

The presence of m5C in different RNA species points to its diverse and context-dependent functions.

Role in mRNA

In messenger RNA, m5C has been shown to influence stability, nuclear export, and translation.[2] The location of m5C within an mRNA molecule appears to be a key determinant of its function. For instance, m5C sites are enriched in the 5' untranslated region (UTR) and near start codons, where they have been observed to be inversely correlated with ribosome association, suggesting a role in modulating translation. Specific reader proteins, such as ALYREF and YBX1, can bind to m5C-modified mRNA to mediate its nuclear export and enhance its stability, respectively.

Role in tRNA

tRNAs are the most abundantly m5C-modified RNA species. The modification is crucial for tRNA structure and function. For example, m5C at position 38 of the anticodon loop in tRNA^(Asp) is required for efficient amino acid charging and translation. Furthermore, m5C modifications in the variable loop and T-stem-loop region contribute to the overall stability of the tRNA structure. In yeast tRNA^(Phe), 5-methylcytidine is essential for the cooperative binding of Mg²⁺ and a subsequent conformational change in the anticodon stem-loop.

Role in Mitochondrial tRNA (mt-tRNA)

Post-transcriptional modifications in mitochondrial tRNAs are critical for mitochondrial protein synthesis. The enzyme NSUN2 has been identified as being responsible for introducing m5C at positions 48-50 in several mammalian mitochondrial tRNAs. The absence of these modifications can have pathological consequences.

Role in rRNA

In ribosomal RNA, m5C is thought to play a role in ensuring translational fidelity.

Oxidized Derivatives of m5C

5-methylcytidine can be further oxidized to 5-hydroxymethylcytidine (hm5C) and 5-formylcytidine (f5C) by enzymes such as the TET family of dioxygenases and ALKBH1. These oxidized forms represent additional layers of regulation. For instance, TET2-mediated oxidation of m5C to hm5C in tRNA has been shown to promote translation. Another derivative, 2'-O-methyl-5-hydroxymethylcytidine (hm5Cm), has been identified as a stable RNA modification.

Enzymatic Regulation of m5C

The levels of m5C are dynamically regulated by the interplay of methyltransferases ("writers") and demethylases ("erasers").

Writers: RNA Methyltransferases

The NSUN (NOP2/Sun domain) family of proteins and DNMT2 (TRDMT1) are the primary enzymes responsible for depositing m5C on RNA.

- NSUN2: This is a major m5C methyltransferase that targets a wide range of RNAs, including cytoplasmic tRNAs, mRNAs, and mitochondrial tRNAs. The majority of tested m5C sites in both mRNAs and non-coding RNAs show a clear dependence on NSUN2.
- NSUN3: This enzyme is involved in the modification of mitochondrial tRNAs.
- NSUN6: This enzyme methylates cytoplasmic tRNAs.
- DNMT2 (TRDMT1): This enzyme specifically methylates cytosine 38 in the anticodon loop of certain tRNAs, such as tRNA^(Asp), tRNA^(Val), and tRNA^(Gly).

Erasers: RNA Demethylases

The removal of the methyl group from m5C is less well understood, but the TET family of enzymes and ALKBH1 have been implicated in the oxidative demethylation of m5C.

- TET (Ten-Eleven Translocation) Enzymes: These dioxygenases can oxidize m5C to hm5C, f5C, and 5-carboxylcytosine (5caC). TET2, in particular, has been shown to oxidize m5C in

tRNAs, thereby promoting translation.

- ALKBH1: This enzyme is a mitochondrial DNA and RNA dioxygenase that is also involved in the demethylation of cytoplasmic tRNAs. It can oxidize m5C at the wobble position of tRNA-Leu-CAA.

Signaling Pathways and Functional Consequences

The deposition and removal of m5C are integral parts of cellular signaling pathways that regulate gene expression.

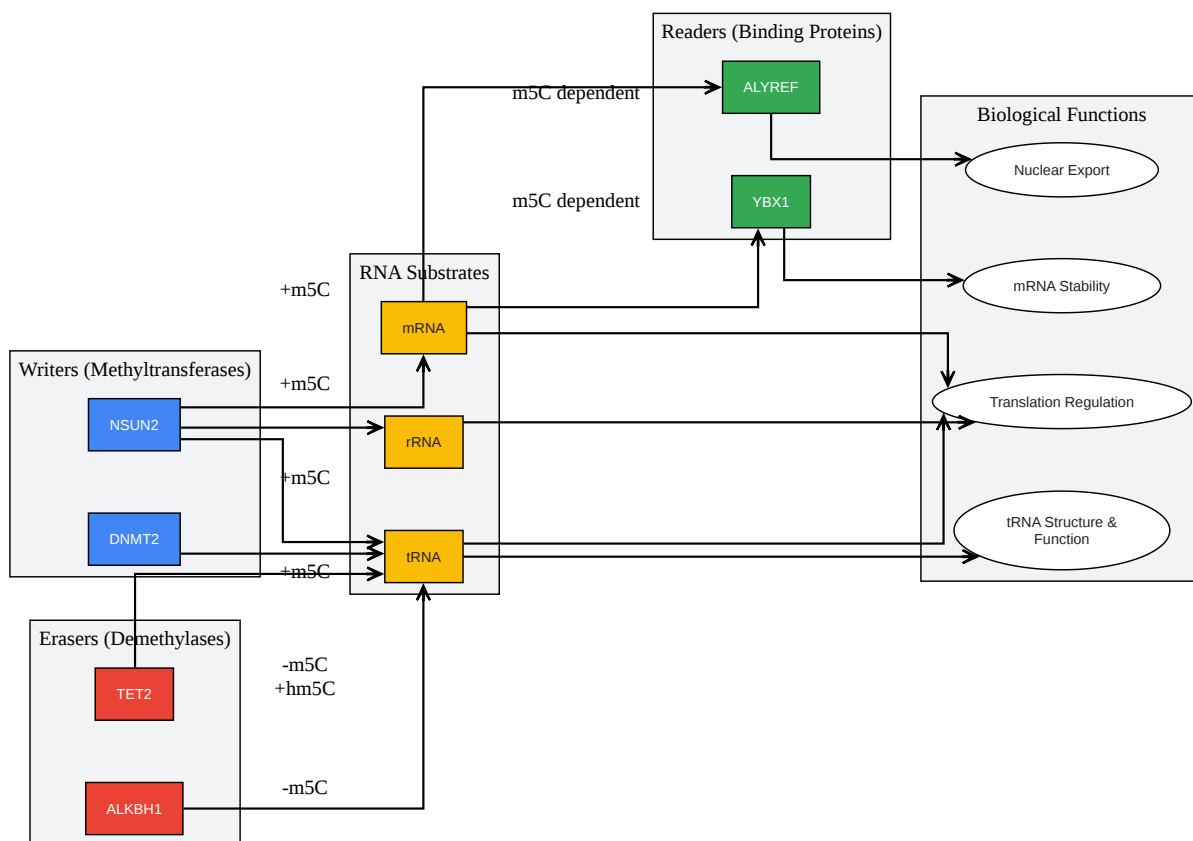

[Click to download full resolution via product page](#)

Caption: The m5C epitranscriptomic regulatory pathway.

Quantitative Data Summary

The following tables summarize key quantitative data related to 5-methylcytidine and its derivatives.

Table 1: Levels of 5-methyl-2'-deoxycytidine (5-MedC) in DNA

Sample Source	5-MedC Level (% of dC)	Reference
Calf Thymus DNA	6.26%	
HeLa Cell DNA	3.02%	
Rat Liver DNA	3.55%	

Table 2: Urinary Levels of 5-methylcytosine (5-meC) and 5-methyl-2'-deoxycytidine (5-medC) in Healthy Males (n=376)

Analyte	Mean Level (ng/mg creatinine)	Standard Deviation	Reference
5-meC	28.4	14.3	
5-medC	7.04	7.2	

Table 3: Detection Limits of 5-meC and 5-medC by LC-MS/MS

Analyte	Detection Limit (pg)	Reference
5-meC	1.2	
5-medC	0.3	

Experimental Protocols

Detailed methodologies are crucial for the accurate study of 5-methylcytidine. Below are outlines of key experimental protocols.

Detection and Quantification of m5C by LC-MS/MS

Liquid chromatography-tandem mass spectrometry (LC-MS/MS) is a highly sensitive and specific method for the detection and quantification of m5C in RNA and DNA.

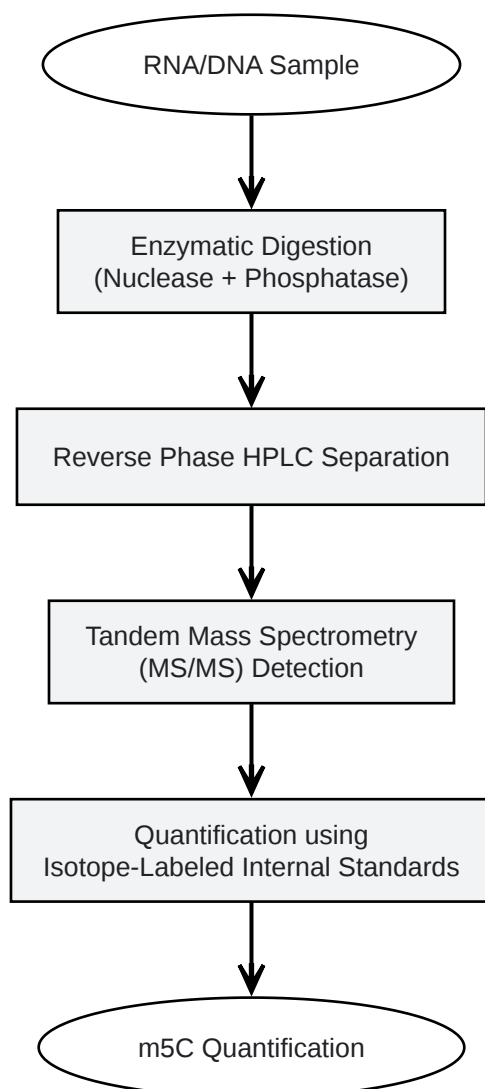

[Click to download full resolution via product page](#)

Caption: Workflow for LC-MS/MS-based m5C detection.

Protocol Outline:

- RNA/DNA Isolation: Isolate total RNA or genomic DNA from the desired source using standard protocols.

- **Enzymatic Hydrolysis:** Digest the purified nucleic acids into individual nucleosides using a cocktail of enzymes, such as nuclease P1 and alkaline phosphatase.
- **LC Separation:** Separate the resulting nucleosides using high-performance liquid chromatography (HPLC) with a reverse-phase column (e.g., C18).
- **MS/MS Detection:** Introduce the separated nucleosides into a tandem mass spectrometer. Use multiple reaction monitoring (MRM) to specifically detect the transition of the parent ion (m5C) to a specific daughter ion.
- **Quantification:** Quantify the amount of m5C by comparing its signal to that of a known amount of a stable isotope-labeled internal standard (e.g., [¹³C,¹⁵N₂]-m5C) that was spiked into the sample prior to digestion.

RNA Bisulfite Sequencing (RNA-BisSeq)

RNA bisulfite sequencing allows for the transcriptome-wide, single-nucleotide resolution mapping of m5C sites. The principle is based on the chemical conversion of unmethylated cytosine to uracil by sodium bisulfite, while m5C remains unchanged.

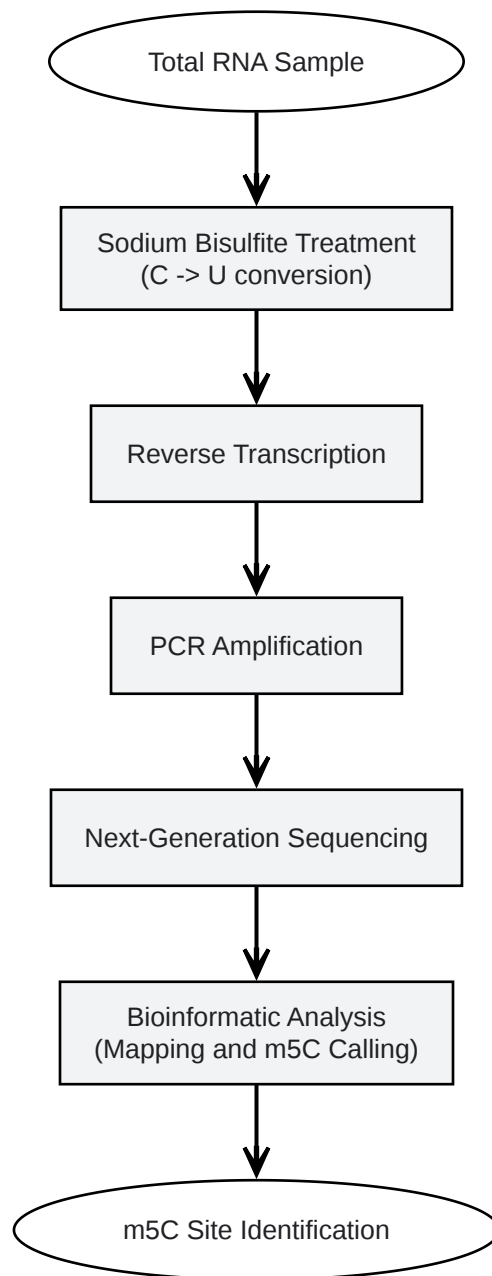

[Click to download full resolution via product page](#)

Caption: Workflow for RNA bisulfite sequencing.

Protocol Outline:

- RNA Isolation and Fragmentation: Isolate total RNA and fragment it to the desired size.
- Bisulfite Conversion: Treat the RNA with sodium bisulfite, which deaminates unmethylated cytosines to uracils. 5-methylcytosine is resistant to this conversion.

- **Reverse Transcription and Library Preparation:** Reverse transcribe the bisulfite-treated RNA into cDNA. During this step, the uracils are read as thymines. Prepare a sequencing library from the resulting cDNA.
- **High-Throughput Sequencing:** Sequence the library using a next-generation sequencing platform.
- **Bioinformatic Analysis:** Align the sequencing reads to a reference genome/transcriptome. Sites that were originally cytosines in the reference but are read as thymines in the sequencing data are identified as unmethylated cytosines. Sites that remain as cytosines are identified as potential m5C sites.

5-Methylcytidine in Disease and as a Therapeutic Target

Aberrant m5C modification has been implicated in the pathogenesis of various diseases, making the enzymes involved in this pathway potential therapeutic targets.

- **Cancer:** Dysregulation of m5C writers and erasers has been observed in several types of cancer. For example, aberrant m5C hypermethylation can contribute to resistance to EGFR inhibitors in non-small cell lung cancer.
- **Neurological Disorders:** Mutations in the NSUN2 gene are associated with autosomal recessive intellectual disability.
- **Mitochondrial Diseases:** Defects in mt-tRNA modification, including m5C, can lead to mitochondrial dysfunction.

The development of small molecule inhibitors or activators of m5C-modifying enzymes represents a promising avenue for therapeutic intervention in these and other diseases.

Conclusion

5-Methoxycytidine and its precursor 5-methylcytidine are emerging as pivotal players in the epitranscriptomic landscape. Their roles in fine-tuning gene expression through the regulation of RNA stability, processing, and translation are becoming increasingly apparent. The methodologies for their detection and the identification of the enzymatic machinery that

governs their dynamic regulation have provided a solid foundation for future research. For professionals in drug development, the m5C pathway offers a novel set of potential therapeutic targets for a range of human diseases. A deeper understanding of the context-specific functions of m5C and its derivatives will undoubtedly pave the way for innovative diagnostic and therapeutic strategies.

Need Custom Synthesis?

BenchChem offers custom synthesis for rare earth carbides and specific isotopic labeling.

Email: info@benchchem.com or [Request Quote Online](#).

References

- 1. RNA 5-methylcytosine modification and its emerging role as an epitranscriptomic mark - PMC [pmc.ncbi.nlm.nih.gov]
- 2. 5-Methylcytosine RNA modification and its roles in cancer and cancer chemotherapy resistance - PMC [pmc.ncbi.nlm.nih.gov]
- To cite this document: BenchChem. [The Emerging Roles of 5-Methoxycytidine: An Epitranscriptomic Regulator]. BenchChem, [2025]. [Online PDF]. Available at: [https://www.benchchem.com/product/b12387523#potential-biological-roles-of-5-methoxycytidine]

Disclaimer & Data Validity:

The information provided in this document is for Research Use Only (RUO) and is strictly not intended for diagnostic or therapeutic procedures. While BenchChem strives to provide accurate protocols, we make no warranties, express or implied, regarding the fitness of this product for every specific experimental setup.

Technical Support: The protocols provided are for reference purposes. Unsure if this reagent suits your experiment? [[Contact our Ph.D. Support Team for a compatibility check](#)]

Need Industrial/Bulk Grade? [Request Custom Synthesis Quote](#)

BenchChem

Our mission is to be the trusted global source of essential and advanced chemicals, empowering scientists and researchers to drive progress in science and industry.

Contact

Address: 3281 E Guasti Rd

Ontario, CA 91761, United States

Phone: (601) 213-4426

Email: info@benchchem.com