

# The Discovery and Development of ATI-2138: A Dual ITK/JAK3 Inhibitor

**Author:** BenchChem Technical Support Team. **Date:** December 2025

## Compound of Interest

Compound Name: *TMX-2138*

Cat. No.: *B15542604*

[Get Quote](#)

An In-depth Technical Guide for Researchers and Drug Development Professionals

## Abstract

ATI-2138 is a novel, orally administered, covalent inhibitor that potently and selectively targets both Interleukin-2-inducible T-cell kinase (ITK) and Janus kinase 3 (JAK3). This dual mechanism of action positions ATI-2138 as a promising therapeutic candidate for a range of T-cell-mediated autoimmune and inflammatory diseases. By simultaneously blocking two key signaling pathways in lymphocytes, ATI-2138 effectively modulates T-cell activation, differentiation, and proliferation. This whitepaper provides a comprehensive overview of the discovery, preclinical development, and clinical evaluation of ATI-2138, presenting key data in a structured format, detailing experimental methodologies, and visualizing complex biological and experimental workflows.

## Introduction

T-cell dysregulation is a central pathological feature of numerous autoimmune and inflammatory disorders. Key signaling pathways that govern T-cell function therefore represent attractive targets for therapeutic intervention. Interleukin-2-inducible T-cell kinase (ITK), a member of the Tec family of kinases, is crucial for T-cell receptor (TCR) signaling, which is the primary pathway for T-cell activation. Janus kinase 3 (JAK3) is a critical component of the signaling cascade for cytokines that utilize the common gamma chain ( $\gamma_c$ ), including IL-2, IL-4, IL-7, IL-9, IL-15, and IL-21. These cytokines are essential for the proliferation and survival of lymphocytes.

ATI-2138 was developed by Aclaris Therapeutics as a dual inhibitor of ITK and JAK3, with the rationale that concurrently targeting both TCR and  $\gamma$ c cytokine signaling would result in a more profound and comprehensive immunomodulatory effect than targeting either pathway alone.[1] [2] This document details the preclinical and clinical data that support the therapeutic potential of ATI-2138.

## Mechanism of Action

ATI-2138 is a covalent inhibitor that forms an irreversible bond with a cysteine residue in the active site of both ITK (Cys442) and JAK3 (Cys909).[3] This covalent binding leads to sustained inhibition of kinase activity. The dual inhibition of ITK and JAK3 by ATI-2138 results in the interruption of two critical signaling pathways in T-cells and other lymphocytes.

## Signaling Pathways

The following diagram illustrates the signaling pathways targeted by ATI-2138.

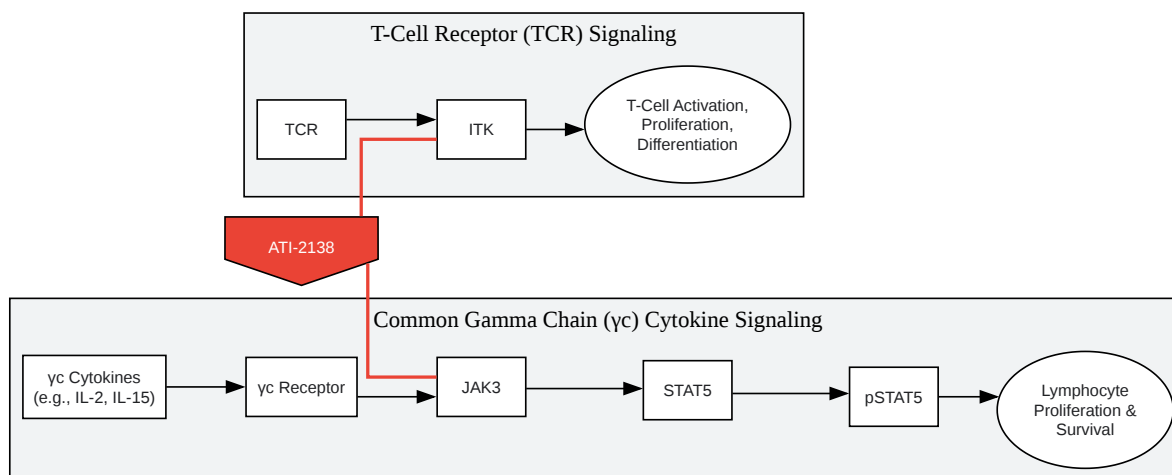

[Click to download full resolution via product page](#)

**Figure 1:** Mechanism of Action of ATI-2138.

## Preclinical Development

The preclinical development of ATI-2138 involved a series of in vitro and in vivo studies to characterize its potency, selectivity, and efficacy.

## Biochemical and Cellular Potency

ATI-2138 demonstrated potent and selective inhibition of ITK and JAK3 in both biochemical and cellular assays.

Table 1: Biochemical Potency of ATI-2138

Kinase	ATI-2138 IC50 (nM)	Ritlecitinib IC50 (nM)
ITK	0.18[4]	7.3[4]
TXK	0.83[4]	4.13[4]
JAK3	0.52[4]	1.8[4]
JAK1	>2200[4]	-
JAK2	>2200[4]	-
Tyk2	>2200[4]	-

Table 2: Cellular Potency of ATI-2138

Assay	Cell Type	Measurement	ATI-2138 IC50 (nM)	Ritlecitinib IC50 (nM)
Th17 Cytokine Production	Human Th17 Cells	IL-17A, IL-21, TNF- $\alpha$	47[4]	760[4]
IFN- $\gamma$ Production (IL-2 induced)	Human Whole Blood	IFN- $\gamma$	10[4]	-
IFN- $\gamma$ Production (IL-15 induced)	Human Whole Blood	IFN- $\gamma$	7[4]	-
STAT5 Phosphorylation (IL-2 induced)	Human PBMCs	pSTAT5	Low-nanomolar[5][6]	-

## Preclinical Efficacy in Animal Models

ATI-2138 has shown significant efficacy in rodent models of autoimmune and inflammatory diseases.

Table 3: Efficacy of ATI-2138 in a Mouse Model of Collagen-Induced Arthritis

Treatment Group	Dose	Reduction in Clinical Arthritis Score
ATI-2138	100 ppm (in food)	92%[4]
ATI-2138	300 ppm (in food)	99%[4]
ATI-2138	1000 ppm (in food)	100%[4]
Ritlecitinib	1000 ppm (in food)	Similar to ATI-2138[4]
Etanercept	-	64%[4]

Table 4: Efficacy of ATI-2138 in a Rat Model of Adjuvant-Induced Arthritis

Treatment Group	Dose	Reduction in Inflammation	Reduction in Histopathology Score
ATI-2138	10 mg/kg (oral)	49% <sup>[4]</sup>	51% <sup>[4]</sup>
ATI-2138	30 mg/kg (oral)	68% <sup>[4]</sup>	74% <sup>[4]</sup>

Table 5: Efficacy of ATI-2138 in a Murine T-Cell Transfer Model of Colitis

Treatment Group	Dose	Outcome
ATI-2138	300 ppm (in food)	Reduced distal and proximal colon and ileum histopathology scores <sup>[4]</sup>
Ritlecitinib	-	Less effective than ATI-2138 <sup>[4]</sup>

## Clinical Development

ATI-2138 has been evaluated in Phase 1 and Phase 2a clinical trials.

### Phase 1 Clinical Trials

Phase 1 single ascending dose (SAD) and multiple ascending dose (MAD) trials were conducted in healthy volunteers to assess the safety, tolerability, pharmacokinetics (PK), and pharmacodynamics (PD) of ATI-2138.

Table 6: Summary of Phase 1 MAD Trial (ATI-2138-PKPD-102)

Parameter	Result
Population	60 healthy subjects[2][7]
Dosing	10mg to 80mg daily for two weeks[2][7]
Safety	Generally well tolerated, no serious adverse events reported.[2][7]
Pharmacokinetics	Dose-proportional PK.[2][7]
Pharmacodynamics	Dose-dependent inhibition of ITK and JAK3 biomarkers; maximal inhibition at 30mg total daily dose.[2][7]

## Phase 2a Clinical Trial in Atopic Dermatitis (NCT06585202)

A Phase 2a open-label, single-arm trial was conducted to evaluate ATI-2138 in patients with moderate-to-severe atopic dermatitis.[1][4]

Table 7: Summary of Phase 2a Trial in Atopic Dermatitis

Parameter	Result
Population	14 patients with moderate-to-severe atopic dermatitis[8]
Dosing	10mg twice daily for 12 weeks[8]
Primary Endpoint (Safety)	Favorable tolerability profile; no severe adverse events.[8]
Secondary Endpoint (Efficacy)	- Mean improvement in EASI score at week 12: 60.5%[9] - Rapid and sustained response observed.[9]
Pharmacodynamics	Strong downregulation of key inflammatory markers (Th1, Th2, Th17) and fibrosis-related markers.[10]

## Experimental Protocols

### In Vitro Assays

- Objective: To determine the half-maximal inhibitory concentration (IC50) of ATI-2138 against a panel of kinases.
- Methodology:
  - Recombinant human kinases (ITK, JAK3, etc.) are incubated with a fluorescently labeled peptide substrate and ATP in a reaction buffer.
  - ATI-2138 is added at various concentrations.
  - The kinase reaction is allowed to proceed for a specified time at a controlled temperature.
  - The reaction is stopped, and the amount of phosphorylated substrate is quantified using a suitable detection method (e.g., fluorescence polarization, time-resolved fluorescence resonance energy transfer).
  - IC50 values are calculated by fitting the dose-response data to a four-parameter logistic equation.
- Objective: To measure the inhibition of IL-2-induced STAT5 phosphorylation in human peripheral blood mononuclear cells (PBMCs).
- Methodology:
  - Human PBMCs are isolated from healthy donor blood.
  - Cells are pre-incubated with varying concentrations of ATI-2138.
  - Cells are stimulated with recombinant human IL-2 to induce STAT5 phosphorylation.
  - The stimulation is stopped by fixing the cells with a fixation buffer (e.g., paraformaldehyde).
  - Cells are permeabilized to allow intracellular staining.

- Cells are stained with a fluorescently conjugated antibody specific for phosphorylated STAT5 (pSTAT5) and cell surface markers (e.g., CD4).
- The level of pSTAT5 in specific cell populations is quantified by flow cytometry.
- Objective: To assess the effect of ATI-2138 on cytokine production in human whole blood.
- Methodology:
  - Heparinized whole blood from healthy donors is collected.
  - The blood is pre-incubated with different concentrations of ATI-2138.
  - Cytokine production is stimulated by adding a stimulant (e.g., anti-CD3/CD28 for ITK-mediated cytokine release, or IL-2/IL-15 for JAK3-mediated cytokine release).
  - The blood is incubated for a specified period to allow for cytokine production.
  - Plasma is separated by centrifugation.
  - The concentration of the cytokine of interest (e.g., IFN- $\gamma$ , IL-17A) in the plasma is measured using an enzyme-linked immunosorbent assay (ELISA) or a multiplex bead-based immunoassay.

## In Vivo Models



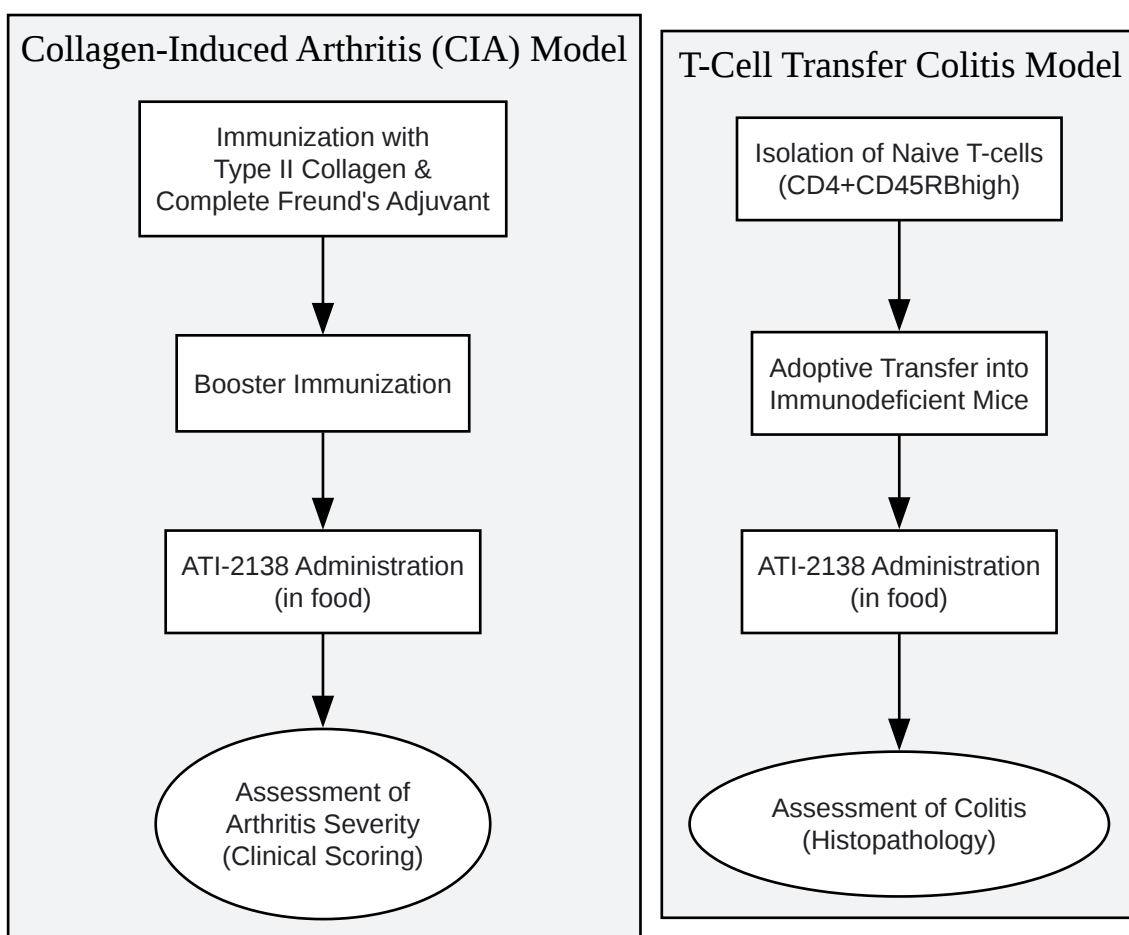

[Click to download full resolution via product page](#)

**Figure 2:** Preclinical Animal Model Workflow.

- Objective: To evaluate the efficacy of ATI-2138 in a model of rheumatoid arthritis.
- Methodology:
  - Induction: DBA/1 mice are immunized with an emulsion of bovine type II collagen and Complete Freund's Adjuvant (CFA) at the base of the tail.
  - Booster: A booster immunization of type II collagen in Incomplete Freund's Adjuvant (IFA) is administered 21 days after the primary immunization.
  - Treatment: ATI-2138 is administered in the chow starting from the day of the booster immunization.

- Assessment: The severity of arthritis in the paws is scored visually on a scale of 0-4 per paw, based on the degree of inflammation and swelling. Clinical scores are recorded regularly.
- Objective: To assess the efficacy of ATI-2138 in a model of inflammatory bowel disease.
- Methodology:
  - Cell Isolation: Naive T-cells (CD4+CD45RBhigh) are isolated from the spleens of donor mice using magnetic-activated cell sorting (MACS) or fluorescence-activated cell sorting (FACS).
  - Adoptive Transfer: The isolated naive T-cells are injected intraperitoneally into immunodeficient recipient mice (e.g., RAG1-/-).
  - Treatment: ATI-2138 is administered in the chow starting a few weeks after T-cell transfer.
  - Assessment: Mice are monitored for weight loss and signs of colitis. At the end of the study, the colon is collected for histopathological analysis to score the degree of inflammation, mucosal ulceration, and crypt hyperplasia.

## Clinical Trial Workflow

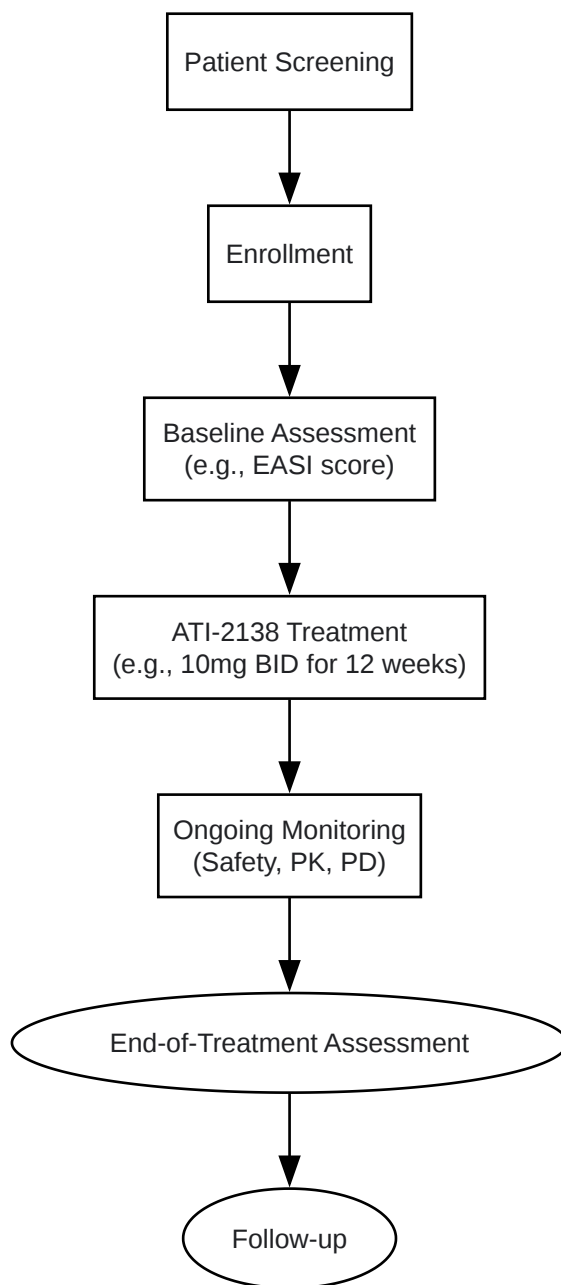

[Click to download full resolution via product page](#)

**Figure 3:** Phase 2a Atopic Dermatitis Trial Workflow.

## Conclusion

ATI-2138 is a potent and selective dual inhibitor of ITK and JAK3 with a promising preclinical and clinical profile. Its unique mechanism of action, targeting both T-cell receptor and common gamma chain cytokine signaling, offers the potential for superior efficacy in a variety of T-cell-mediated diseases. The data presented in this whitepaper demonstrate the robust anti-

inflammatory and immunomodulatory effects of ATI-2138 in vitro, in vivo, and in a clinical setting. The favorable safety and tolerability profile observed in clinical trials further supports its continued development as a novel therapeutic agent for patients with autoimmune and inflammatory disorders. Further clinical investigation is warranted to fully elucidate the therapeutic potential of ATI-2138 in various indications.

### *Need Custom Synthesis?*

*BenchChem offers custom synthesis for rare earth carbides and specific isotopic labeling.*

*Email: [info@benchchem.com](mailto:info@benchchem.com) or [Request Quote Online](#).*

## References

- 1. hcplive.com [hcplive.com]
- 2. Collagen-induced arthritis - PubMed [pubmed.ncbi.nlm.nih.gov]
- 3. docs.publicnow.com [docs.publicnow.com]
- 4. ClinicalTrials.gov [clinicaltrials.gov]
- 5. T cell transfer model of chronic colitis: concepts, considerations, and tricks of the trade - PMC [pmc.ncbi.nlm.nih.gov]
- 6. Characterization of the dual ITK/JAK3 small molecule covalent inhibitor ATI-2138 - PubMed [pubmed.ncbi.nlm.nih.gov]
- 7. Aclaris unveils positive data from trial of ATI-2138 [clinicaltrialsarena.com]
- 8. Aclaris Reports Strong Phase 2a Results for ATI-2138 in Atopic Dermatitis [clival.com]
- 9. Frontiers | Evaluating STAT5 Phosphorylation as a Mean to Assess T Cell Proliferation [frontiersin.org]
- 10. researchgate.net [researchgate.net]
- To cite this document: BenchChem. [The Discovery and Development of ATI-2138: A Dual ITK/JAK3 Inhibitor]. BenchChem, [2025]. [Online PDF]. Available at: [https://www.benchchem.com/product/b15542604#discovery-and-development-of-ati-2138]

---

### Disclaimer & Data Validity:

The information provided in this document is for Research Use Only (RUO) and is strictly not intended for diagnostic or therapeutic procedures. While BenchChem strives to provide accurate protocols, we make no warranties, express or implied, regarding the fitness of this product for every specific experimental setup.

**Technical Support:** The protocols provided are for reference purposes. Unsure if this reagent suits your experiment? [[Contact our Ph.D. Support Team for a compatibility check](#)]

**Need Industrial/Bulk Grade?** [Request Custom Synthesis Quote](#)

## BenchChem

Our mission is to be the trusted global source of essential and advanced chemicals, empowering scientists and researchers to drive progress in science and industry.

### Contact

Address: 3281 E Guasti Rd  
Ontario, CA 91761, United States  
Phone: (601) 213-4426  
Email: [info@benchchem.com](mailto:info@benchchem.com)