

The Biosynthesis of Jasmonates in Plants: A Technical Guide

Author: BenchChem Technical Support Team. **Date:** December 2025

Compound of Interest

Compound Name: *Jasminoid A*

Cat. No.: *B1164407*

[Get Quote](#)

November 20, 2025

Introduction

Jasmonates are a class of lipid-derived plant hormones that play critical roles in a wide array of physiological processes, including growth, development, and defense against biotic and abiotic stresses.^[1] The quintessential member of this family is jasmonic acid (JA), first isolated from the fungus *Lasiodiplodia theobromae* and its methyl ester, methyl jasmonate (MeJA), identified in the essential oil of *Jasminum grandiflorum*.^{[1][2]} The name "jasmonate" itself is derived from the jasmine plant, renowned for these fragrant compounds.^[3] This guide provides an in-depth technical overview of the biosynthesis of jasmonates.

It is important to note that a search of the scientific literature did not yield specific information on a compound named "**Jasminoid A**." Therefore, this document will focus on the well-established and scientifically validated biosynthesis pathway of jasmonic acid, which serves as the precursor for the diverse array of jasmonate-related compounds found in plants.

The Octadecanoid Pathway: Biosynthesis of Jasmonic Acid

The primary pathway for jasmonic acid biosynthesis is the octadecanoid pathway, which initiates in the chloroplasts and concludes in the peroxisomes.^[1] This multi-step process involves the enzymatic conversion of α -linolenic acid, a common fatty acid in plant membranes.

Chloroplast-Localized Events

The initial steps of jasmonate synthesis occur within the chloroplasts.^[1]

- **Release of α -Linolenic Acid:** The pathway is initiated by the release of α -linolenic acid (α -LeA) from plastid membranes, a process mediated by phospholipases.^[4]
- **Oxygenation by Lipoxygenase (LOX):** α -Linolenic acid is then oxygenated by 13-lipoxygenase (13-LOX) to form (13S)-hydroperoxyoctadecatrienoic acid (13-HPOT).^[4]
- **Dehydration by Allene Oxide Synthase (AOS):** The 13-HPOT is rapidly converted to an unstable allene oxide, 12,13(S)-epoxy-octadecatrienoic acid, by the enzyme allene oxide synthase (AOS).^[4]
- **Cyclization by Allene Oxide Cyclase (AOC):** Allene oxide cyclase (AOC) catalyzes the cyclization of the allene oxide to form (9S,13S)-12-oxo-phytodienoic acid (OPDA).^[4]

Peroxisome-Localized Events

OPDA is then transported from the chloroplast to the peroxisome for the final steps of jasmonic acid synthesis.^[1]

- **Reduction by OPDA Reductase (OPR):** Inside the peroxisome, the cyclopentenone ring of OPDA is reduced by 12-oxophytodienoate reductase (OPR3) to yield 3-oxo-2-(2'(Z)-pentenyl)-cyclopentane-1-octanoic acid.
- **β -Oxidation:** The final conversion to (+)-7-iso-jasmonic acid occurs through a series of three cycles of β -oxidation. This process shortens the carboxylic acid side chain. Subsequently, jasmonic acid is formed through spontaneous isomerization.^[1]

Key Enzymes in Jasmonate Biosynthesis

The following table summarizes the key enzymes involved in the jasmonic acid biosynthetic pathway.

Enzyme	Abbreviation	Localization	Substrate	Product
Lipoxygenase	LOX	Chloroplast	α -Linolenic Acid	(13S)-hydroperoxyoctadecatrienoic acid (13-HPOT)
Allene Oxide Synthase	AOS	Chloroplast	13-HPOT	12,13(S)-epoxy-octadecatrienoic acid
Allene Oxide Cyclase	AOC	Chloroplast	12,13(S)-epoxy-octadecatrienoic acid	(9S,13S)-12-oxo-phytodienoic acid (OPDA)
12-oxophytodienoate Reductase	OPR	Peroxisome	OPDA	3-oxo-2-(2'(Z)-pentenyl)-cyclopentane-1-octanoic acid

Jasmonate Derivatives

Jasmonic acid can be further metabolized into a variety of active or inactive derivatives.^[1] These modifications contribute to the diverse signaling roles of jasmonates. Common derivatives include:

- Methyl Jasmonate (MeJA): A volatile compound formed by the methylation of jasmonic acid.^[1]
- Jasmonoyl-isoleucine (JA-Ile): An amino acid conjugate that is a critical signaling molecule in plant defense.
- Tuberonic acid (12-hydroxyjasmonic acid): Involved in processes like tuber formation in potatoes.^[5]

Experimental Protocols

The elucidation of the jasmonate biosynthetic pathway has been made possible through a variety of experimental techniques. Below are generalized protocols for key experiments.

Enzyme Assays

- Lipoxygenase (LOX) Activity Assay:
 - Prepare a crude protein extract from plant tissue.
 - Incubate the extract with a solution of linolenic acid.
 - Monitor the formation of conjugated dienes, a product of LOX activity, by measuring the increase in absorbance at 234 nm using a spectrophotometer.
- Allene Oxide Synthase (AOS) and Allene Oxide Cyclase (AOC) Coupled Assay:
 - Incubate a protein extract with 13-HPOT (the product of the LOX reaction).
 - The reaction is terminated at various time points.
 - The products (OPDA) are extracted with an organic solvent (e.g., ethyl acetate).
 - The extracted products are then analyzed and quantified using techniques such as High-Performance Liquid Chromatography (HPLC) or Gas Chromatography-Mass Spectrometry (GC-MS).

Metabolite Profiling

- Extraction of Jasmonates:
 - Homogenize plant tissue in a solvent mixture, typically containing an organic solvent like ethyl acetate or methanol, often with an acidic aqueous phase to improve extraction efficiency.
 - Include internal standards (e.g., deuterated jasmonic acid) for accurate quantification.
 - Centrifuge the homogenate to pellet cell debris.
 - Collect the supernatant containing the metabolites.
- Analysis by LC-MS/MS (Liquid Chromatography-Tandem Mass Spectrometry):

- The extracted metabolites are separated using a liquid chromatography system.
- The separated compounds are then introduced into a mass spectrometer for detection and quantification.
- Specific parent and daughter ion transitions are monitored for each jasmonate to ensure accurate identification and quantification.

Visualizations

Diagram of the Jasmonic Acid Biosynthesis Pathway

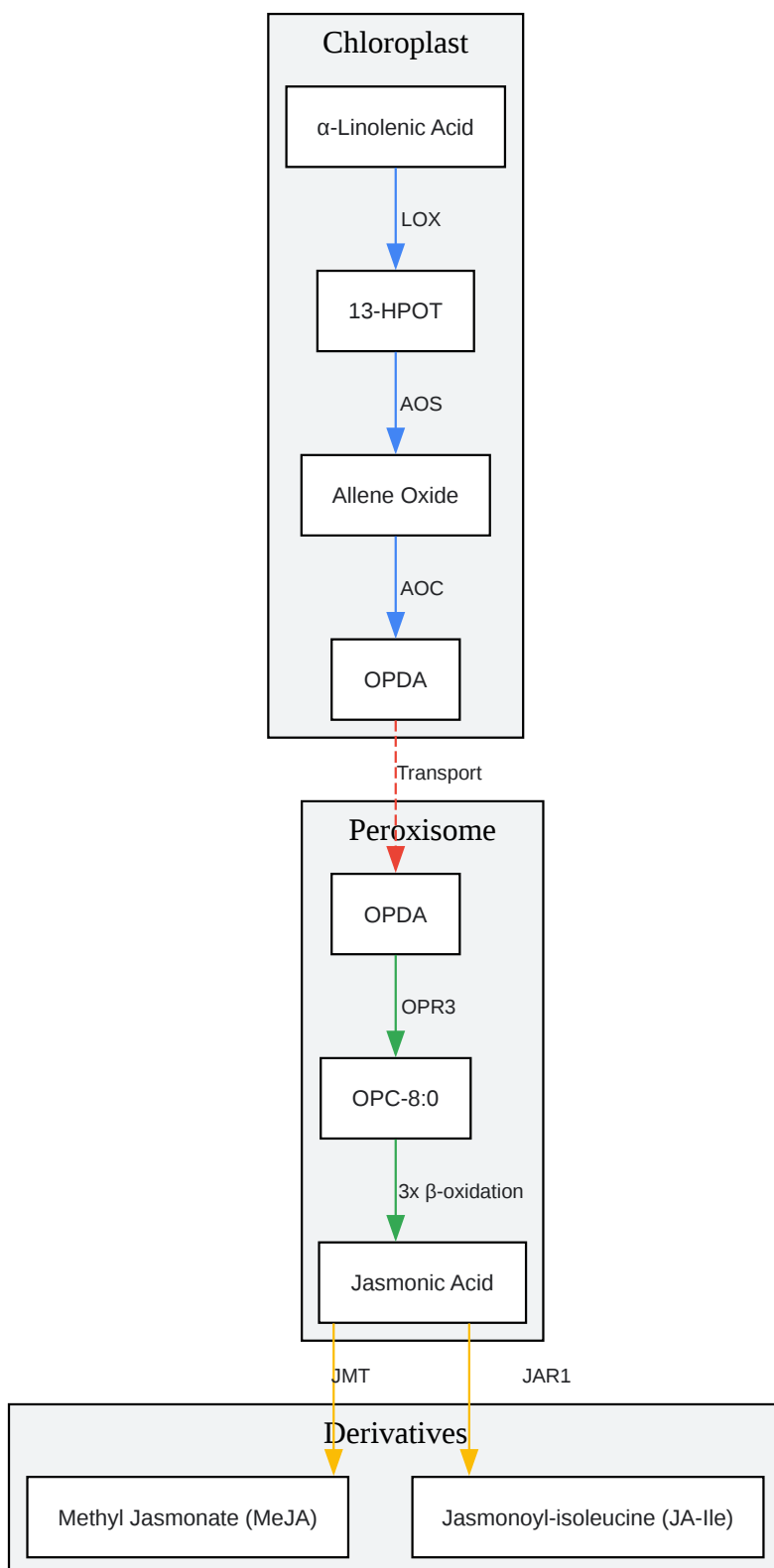

[Click to download full resolution via product page](#)

Caption: The biosynthetic pathway of jasmonic acid and its primary derivatives.

Experimental Workflow for Jasmonate Analysis

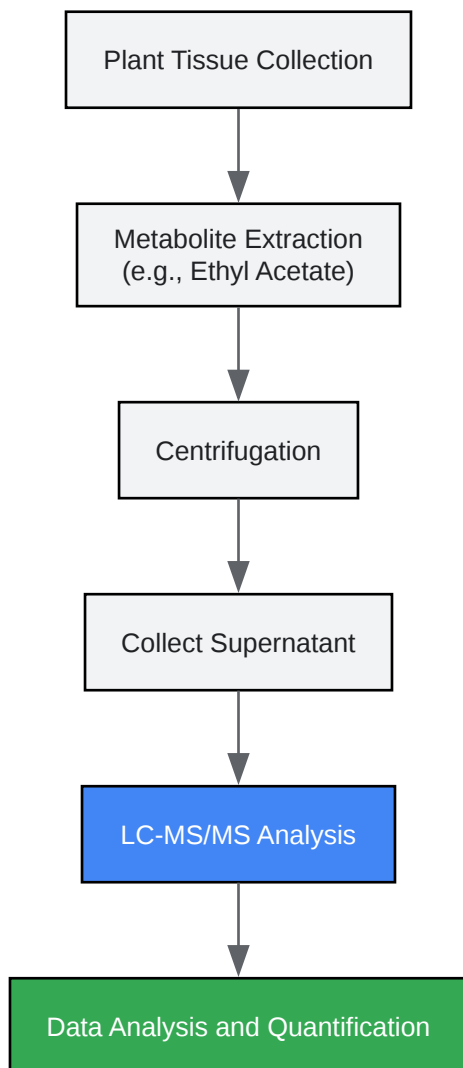

[Click to download full resolution via product page](#)

Caption: A generalized workflow for the extraction and analysis of jasmonates from plant tissues.

Conclusion

The biosynthesis of jasmonic acid via the octadecanoid pathway is a fundamental process in plant biology, giving rise to a diverse suite of signaling molecules that are essential for plant survival and interaction with the environment. Understanding this pathway is crucial for researchers in plant science and for professionals in drug development who may seek to harness the bioactivity of these compounds or engineer plants with enhanced defensive

capabilities. While the specific compound "**Jasminoid A**" remains uncharacterized in the current body of scientific literature, the foundational knowledge of jasmonate biosynthesis provides a robust framework for the study of this important class of plant hormones.

Need Custom Synthesis?

BenchChem offers custom synthesis for rare earth carbides and specific isotopic labeling.

Email: info@benchchem.com or [Request Quote Online](#).

References

- 1. Jasmonate - Wikipedia [en.wikipedia.org]
- 2. Therapeutic Potential of Jasmonic Acid and Its Derivatives - PMC [pmc.ncbi.nlm.nih.gov]
- 3. Jasmine - Wikipedia [en.wikipedia.org]
- 4. Jasmonates in plant growth and development and elicitation of secondary metabolites: An updated overview - PMC [pmc.ncbi.nlm.nih.gov]
- 5. academic.oup.com [academic.oup.com]
- To cite this document: BenchChem. [The Biosynthesis of Jasmonates in Plants: A Technical Guide]. BenchChem, [2025]. [Online PDF]. Available at: [https://www.benchchem.com/product/b1164407#biosynthesis-pathway-of-jasminoid-a-in-plants]

Disclaimer & Data Validity:

The information provided in this document is for Research Use Only (RUO) and is strictly not intended for diagnostic or therapeutic procedures. While BenchChem strives to provide accurate protocols, we make no warranties, express or implied, regarding the fitness of this product for every specific experimental setup.

Technical Support: The protocols provided are for reference purposes. Unsure if this reagent suits your experiment? [[Contact our Ph.D. Support Team for a compatibility check](#)]

Need Industrial/Bulk Grade? [Request Custom Synthesis Quote](#)

BenchChem

Our mission is to be the trusted global source of essential and advanced chemicals, empowering scientists and researchers to drive progress in science and industry.

Contact

Address: 3281 E Guasti Rd

Ontario, CA 91761, United States

Phone: (601) 213-4426

Email: info@benchchem.com