

# Technical Support Center: Wye-354 and the PI3K Signaling Pathway

**Author:** BenchChem Technical Support Team. **Date:** December 2025

## Compound of Interest

Compound Name: Wye-354

Cat. No.: B612256

[Get Quote](#)

This technical support center provides troubleshooting guides and frequently asked questions (FAQs) for researchers, scientists, and drug development professionals using the mTOR inhibitor **Wye-354**, with a specific focus on its off-target effects on the PI3K pathway.

## Frequently Asked Questions (FAQs)

Q1: What is the primary molecular target of **Wye-354**?

A1: **Wye-354** is a potent, ATP-competitive inhibitor of the mammalian target of rapamycin (mTOR).[1][2] It effectively inhibits both mTOR Complex 1 (mTORC1) and mTOR Complex 2 (mTORC2).[3][4] Its high potency against mTOR is demonstrated by an IC50 value of approximately 5 nM in enzymatic assays.[1][3]

Q2: Does **Wye-354** exhibit off-target activity against the PI3K pathway?

A2: Yes, **Wye-354** has known off-target effects against some isoforms of Phosphoinositide 3-kinase (PI3K).[1] Specifically, it has been shown to inhibit PI3K $\alpha$  and PI3K $\gamma$  at micromolar concentrations, making it significantly less potent against these kinases compared to its primary target, mTOR.[3][4]

Q3: What are the specific IC50 values of **Wye-354** for its primary and off-target kinases?

A3: The inhibitory concentrations for **Wye-354** vary significantly between its on-target (mTOR) and off-targets (PI3K isoforms). This selectivity is crucial for experimental design. **Wye-354** is

over 100-fold more selective for mTOR than for PI3K $\alpha$  and over 500-fold more selective for mTOR than for PI3K $\gamma$ .<sup>[1]</sup>

## Data Presentation

Table 1: **Wye-354** Inhibitory Activity (IC<sub>50</sub>)

Target	IC <sub>50</sub> Value	Reference
mTOR	5 nM	[1][3]
PI3K $\alpha$	1.89 $\mu$ M	[3][4]
PI3K $\gamma$	7.37 $\mu$ M	[3][4]
PI3K $\delta$	Weakly Inhibited	[5]

| PI3K $\beta$  | No Apparent Activity |[5] |

## Troubleshooting and Experimental Design

Q4: I am observing inhibition of Akt phosphorylation at Threonine 308 (p-Akt T308). Is this an expected off-target effect of **Wye-354**?

A4: Inhibition of p-Akt at Serine 473 (S473) is the expected on-target effect of **Wye-354** via mTORC2 inhibition.<sup>[1][6]</sup> In contrast, phosphorylation at Threonine 308 (T308) is primarily mediated by PDK1, which is downstream of PI3K. Significant inhibition of p-Akt (T308) suggests that the concentration of **Wye-354** being used is high enough to cause off-target inhibition of PI3K $\alpha$ .<sup>[7]</sup> Studies have shown that **Wye-354** selectively inhibits p-Akt (S473) with little to no significant inhibition of p-Akt (T308) at concentrations that effectively block mTOR.<sup>[6]</sup> <sup>[7]</sup> If you observe a reduction in p-Akt (T308), you are likely operating in the micromolar range where PI3K $\alpha$  is inhibited.<sup>[3][4]</sup>

Q5: How can I design my experiment to isolate the effects of mTOR inhibition from the off-target effects on PI3K?

A5: To ensure you are observing mTOR-specific effects, it is critical to use **Wye-354** at a concentration that is potent for mTOR but well below the IC<sub>50</sub> for PI3K $\alpha$  (1.89  $\mu$ M). A

concentration range of 10 nM to 200 nM is often effective for inhibiting mTORC1 and mTORC2 in cells.[1][2] To confirm the specificity of your observations, consider the following control experiments:

- Use a structurally different mTOR inhibitor: Comparing results with another mTOR inhibitor like Torin1 can help confirm that the observed phenotype is due to mTOR inhibition.[5]
- Use a specific PI3K inhibitor: Treat cells with a selective PI3K inhibitor (e.g., a p110 $\alpha$ -specific inhibitor) to compare the phenotype with that observed with high-concentration **Wye-354**.
- Perform a dose-response curve: Analyze the effects of **Wye-354** across a wide range of concentrations. Effects seen at low nanomolar concentrations are likely mTOR-mediated, while effects appearing only at high nanomolar to micromolar concentrations may be due to off-target PI3K inhibition.

Q6: What are the key downstream markers to differentiate between mTOR and PI3K pathway inhibition?

A6: Monitoring specific phosphorylation events is the most effective way to distinguish between on-target and off-target effects.

Table 2: Key Phosphorylation Sites for Pathway Analysis

Phospho-Protein	Pathway	Significance
p-S6K (T389)	mTORC1	A direct and reliable marker for mTORC1 activity.[1][7]
p-Akt (S473)	mTORC2	A direct marker for mTORC2 activity. Inhibition is an on-target effect of Wye-354.[1][6][7]

| p-Akt (T308) | PI3K / PDK1 | A marker for PI3K pathway activity. Inhibition indicates an off-target effect of **Wye-354** at higher concentrations.[6][7] |

## Visualizations

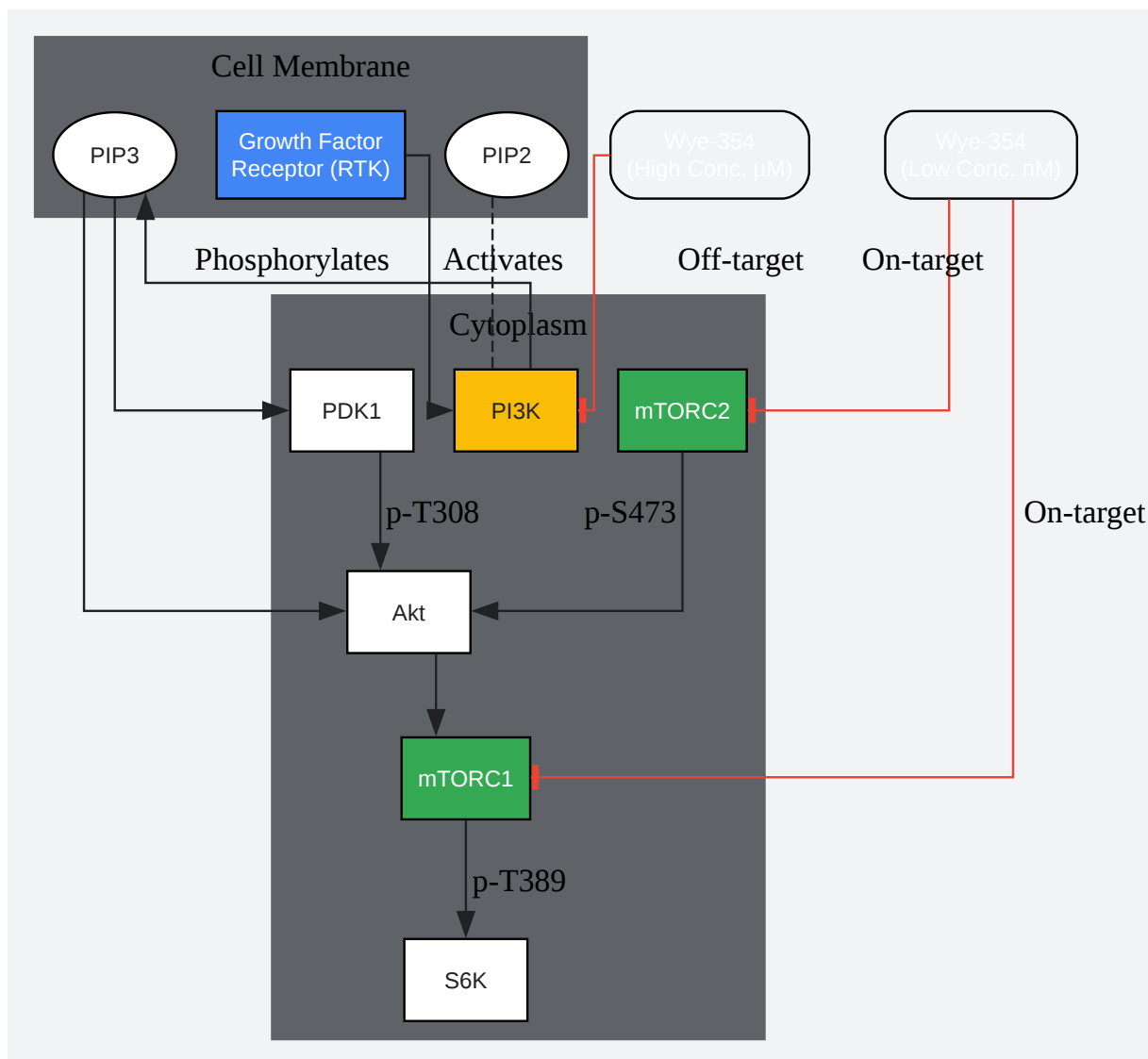

[Click to download full resolution via product page](#)

Caption: PI3K/Akt/mTOR pathway showing **Wye-354** inhibition points.

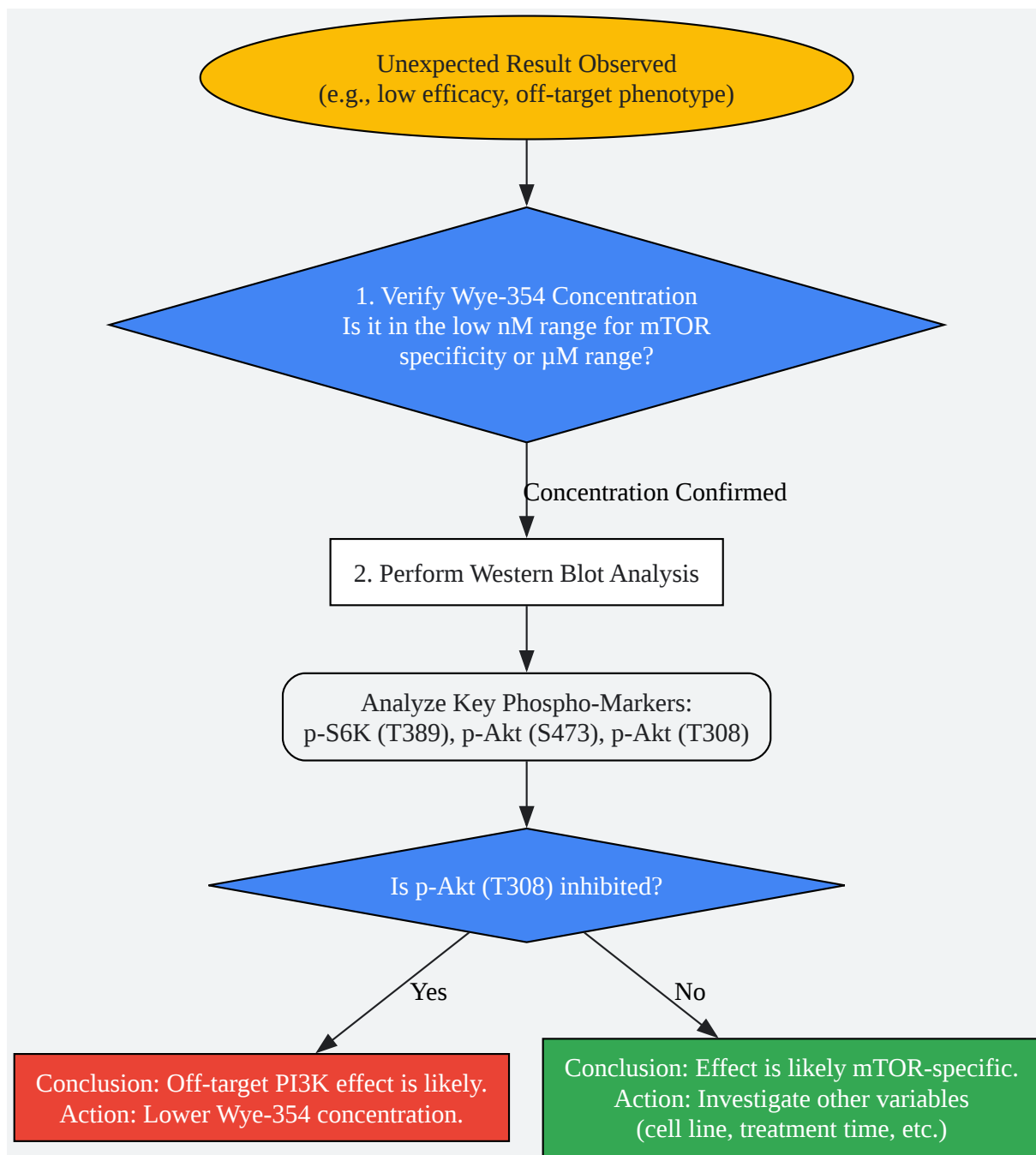

[Click to download full resolution via product page](#)

Caption: Troubleshooting flowchart for unexpected experimental results.

## Key Experimental Protocols

### Protocol 1: Western Blotting for PI3K/mTOR Pathway Activation

This protocol outlines the steps to assess the phosphorylation status of key proteins in the PI3K/mTOR pathway following treatment with **Wye-354**.

- Cell Culture and Treatment:
  - Plate cells (e.g., HEK293, U87MG, MDA-MB-361) at a desired density and allow them to adhere overnight.[1]
  - Starve cells in serum-free media for 4-6 hours to reduce basal pathway activation.
  - Treat cells with a dose-range of **Wye-354** (e.g., 10 nM, 100 nM, 1  $\mu$ M, 5  $\mu$ M) for a specified time (e.g., 1-2 hours).[1] Include a vehicle control (DMSO).
  - (Optional) Stimulate with a growth factor (e.g., insulin or EGF) for the final 15-30 minutes of treatment to induce pathway activation.
- Lysate Preparation:
  - Wash cells twice with ice-cold PBS.
  - Lyse cells on ice using RIPA buffer supplemented with protease and phosphatase inhibitors.
  - Scrape cells, collect the lysate, and centrifuge at 14,000 rpm for 15 minutes at 4°C.
  - Collect the supernatant and determine protein concentration using a BCA or Bradford assay.
- SDS-PAGE and Immunoblotting:
  - Denature 20-40  $\mu$ g of protein per sample by boiling in Laemmli sample buffer.

- Separate proteins on an 8-12% SDS-PAGE gel and transfer to a PVDF or nitrocellulose membrane.
- Block the membrane with 5% non-fat milk or BSA in TBST for 1 hour at room temperature.
- Incubate the membrane with primary antibodies overnight at 4°C. Recommended antibodies:
  - Phospho-S6K (Thr389)
  - Phospho-Akt (Ser473)
  - Phospho-Akt (Thr308)
  - Total S6K, Total Akt,  $\beta$ -actin (as loading controls)
- Wash the membrane three times with TBST.
- Incubate with HRP-conjugated secondary antibody for 1 hour at room temperature.
- Wash three times with TBST.
- Visualize bands using an ECL substrate and an imaging system. Quantify band intensity using software like ImageJ.[7]

## Protocol 2: In Vitro Kinase Assay (IC50 Determination)

This protocol provides a general workflow to determine the IC50 of **Wye-354** against a target kinase. Assays are often performed using FRET-based technologies or by measuring ATP consumption.[5][8]

- Assay Preparation:
  - Prepare an assay buffer suitable for the kinase reaction (typically includes HEPES, MgCl<sub>2</sub>, DTT, and BSA).
  - Dilute the recombinant kinase (e.g., mTOR, PI3K $\alpha$ ) to the desired concentration in the assay buffer. The enzyme concentration should be in the linear range of the assay.[8]

- Prepare the kinase-specific substrate (e.g., His6-S6K for mTORC1, His6-AKT for mTORC2) and ATP.[1][6] The ATP concentration is often set near its  $K_m$  for the enzyme to ensure competitive inhibitors are evaluated accurately.[8]
- Inhibitor Dilution:
  - Perform a serial dilution of **Wye-354** in DMSO, then further dilute in the assay buffer to achieve the final desired concentrations.
- Kinase Reaction:
  - In a 96-well or 384-well plate, add the kinase, the substrate, and the diluted **Wye-354**.
  - Allow the enzyme and inhibitor to pre-incubate for 10-15 minutes.
  - Initiate the reaction by adding ATP.
  - Incubate the reaction at room temperature or 30°C for a fixed period (e.g., 30-60 minutes).
- Detection and Analysis:
  - Stop the reaction and measure the output signal (e.g., fluorescence for FRET, luminescence for ADP generation).
  - Plot the percentage of kinase activity against the logarithm of the **Wye-354** concentration.
  - Fit the data to a four-parameter logistic curve to calculate the IC50 value.

### Need Custom Synthesis?

BenchChem offers custom synthesis for rare earth carbides and specific isotopic labeling.

Email: [info@benchchem.com](mailto:info@benchchem.com) or [Request Quote Online](#).

## References

- 1. selleckchem.com [selleckchem.com]
- 2. abmole.com [abmole.com]



- 3. medchemexpress.com [medchemexpress.com]
- 4. medchemexpress.com [medchemexpress.com]
- 5. scholar.harvard.edu [scholar.harvard.edu]
- 6. apexbt.com [apexbt.com]
- 7. aacrjournals.org [aacrjournals.org]
- 8. Assessing the Inhibitory Potential of Kinase Inhibitors In Vitro: Major Pitfalls and Suggestions for Improving Comparability of Data Using CK1 Inhibitors as an Example - PMC [pmc.ncbi.nlm.nih.gov]
- To cite this document: BenchChem. [Technical Support Center: Wye-354 and the PI3K Signaling Pathway]. BenchChem, [2025]. [Online PDF]. Available at: [https://www.benchchem.com/product/b612256#wye-354-off-target-effects-on-pi3k-pathway]

---

#### Disclaimer & Data Validity:

The information provided in this document is for Research Use Only (RUO) and is strictly not intended for diagnostic or therapeutic procedures. While BenchChem strives to provide accurate protocols, we make no warranties, express or implied, regarding the fitness of this product for every specific experimental setup.

**Technical Support:** The protocols provided are for reference purposes. Unsure if this reagent suits your experiment? [[Contact our Ph.D. Support Team for a compatibility check](#)]

**Need Industrial/Bulk Grade?** [Request Custom Synthesis Quote](#)

## BenchChem

Our mission is to be the trusted global source of essential and advanced chemicals, empowering scientists and researchers to drive progress in science and industry.

#### Contact

Address: 3281 E Guasti Rd  
Ontario, CA 91761, United States  
Phone: (601) 213-4426  
Email: [info@benchchem.com](mailto:info@benchchem.com)