

# Technical Support Center: Validating the Specificity of BIM 23052

**Author:** BenchChem Technical Support Team. **Date:** December 2025

## Compound of Interest

Compound Name: BIM 23052

Cat. No.: B15617972

[Get Quote](#)

Welcome to the technical support center for researchers utilizing **BIM 23052**. This resource provides detailed troubleshooting guides, frequently asked questions (FAQs), and experimental protocols to help you design and execute robust control experiments to validate the specificity of **BIM 23052** for its target receptors.

## Frequently Asked Questions (FAQs) & Troubleshooting Guides

This section addresses common issues and questions that may arise during your experiments with **BIM 23052**.

### General Questions

Q1: What is **BIM 23052** and what is its primary target?

A1: **BIM 23052** is a synthetic linear octapeptide analog of somatostatin.[1] It is described as a somatostatin receptor 5 (sst5) agonist.[2] However, it is important to note that it also exhibits binding affinity for other somatostatin receptor subtypes, particularly sst2, and to a lesser extent, sst1 and sst4. Therefore, validating its specificity for your experimental system is crucial.

Q2: Why is it critical to perform control experiments for **BIM 23052**'s specificity?

A2: As **BIM 23052** shows affinity for multiple somatostatin receptor subtypes, any observed biological effect could be due to its action on sst5, other sst subtypes, or a combination thereof. Control experiments are essential to definitively attribute the observed effects to the intended sst5 target and to rule out off-target effects, ensuring the validity and accuracy of your research findings.

## Troubleshooting Experimental Assays

Below are troubleshooting guides for common assays used to characterize the specificity of **BIM 23052**.

Problem	Possible Cause(s)	Recommended Solution(s)
High non-specific binding	Radioligand concentration is too high.	Use a radioligand concentration at or below its $K_d$ value.
Insufficient washing.	Increase the number and volume of wash steps with ice-cold buffer.	
Hydrophobic interactions of the ligand with the filter or plate.	Add 0.1% BSA to the assay buffer. Consider pre-treating filters with polyethyleneimine (PEI).	
Low or no specific binding	Receptor expression is low in the chosen cell line or tissue.	Use a cell line known to overexpress the target receptor. Confirm receptor expression via Western blot or qPCR.
Incorrect assay conditions (pH, ionic strength).	Optimize the assay buffer composition.	
Degraded radioligand or test compound.	Use fresh stocks and store them properly as recommended by the manufacturer.	
Inconsistent results between experiments	Variability in cell passage number or health.	Use cells within a consistent and low passage number range. Ensure cells are healthy and at the correct confluency.
Pipetting errors.	Use calibrated pipettes and be consistent with pipetting techniques.	

Problem	Possible Cause(s)	Recommended Solution(s)
No inhibition of forskolin-stimulated cAMP	Low receptor expression or coupling to Gi.	Use a cell line with confirmed high expression and functional coupling of the target sst subtype.
BIM 23052 is not an agonist at the target receptor.	Verify with a known agonist for that receptor subtype.	
Phosphodiesterase (PDE) activity is too high, degrading cAMP rapidly.	Include a PDE inhibitor, such as IBMX (0.5 mM), in your assay buffer.[3]	
High basal cAMP levels	Cells are over-stimulated or stressed.	Ensure cells are not overgrown and handle them gently.
Large well-to-well variability	Uneven cell plating.	Ensure a single-cell suspension before plating and use appropriate plating techniques.
Inconsistent stimulation time.	Use a multichannel pipette or automated liquid handler for simultaneous addition of compounds.	

Problem	Possible Cause(s)	Recommended Solution(s)
No calcium signal upon BIM 23052 stimulation	The sst subtype does not couple to the Gq pathway to induce calcium release.	Co-express a promiscuous G protein, such as Gα16, to force coupling to the PLC/calcium pathway.
Low receptor expression.	Use a cell line with higher receptor expression.	
Dye loading issues.	Ensure proper dye concentration and incubation time. Check for dye extrusion by organic anion transporters (probenecid can be added to inhibit this).	
High background fluorescence	Autofluorescence from the compound or cells.	Run a control with the compound and no cells, and cells with no compound.
Cell death or membrane damage.	Ensure cell viability and handle cells gently.	
Rapid signal decay	Receptor desensitization or internalization.	This is a normal physiological response. Analyze the peak of the response.

Problem	Possible Cause(s)	Recommended Solution(s)
No observable internalization (Flow Cytometry/Imaging)	The receptor subtype does not internalize upon agonist binding, or internalizes very slowly.	Increase the incubation time with BIM 23052. Confirm with a known internalizing agonist for that receptor.
Antibody is binding to an epitope that is not accessible or is masked after activation.	Use a different antibody targeting a different epitope (e.g., an N-terminal tag).	
Fixation/permeabilization artifacts.	For surface staining, perform all steps on ice with ice-cold buffers to prevent internalization before analysis. [4] Optimize fixation and permeabilization protocols for intracellular targets.	
High background staining (Flow Cytometry)	Non-specific antibody binding.	Use an Fc receptor blocking reagent. Include an isotype control antibody.
Dead cells are non-specifically taking up the antibody.	Use a viability dye to exclude dead cells from the analysis.	
Weak signal (Imaging)	Low receptor expression.	Use a cell line with higher receptor expression or a brighter fluorophore.
Photobleaching.	Minimize exposure to the excitation light source. Use an anti-fade mounting medium.	

## Quantitative Data Summary

The following tables summarize the known binding affinities and functional potencies of **BIM 23052** for the five human somatostatin receptor subtypes. This data is compiled from various sources and should be used as a reference. It is highly recommended to determine these values in your specific experimental system.

Table 1: Binding Affinities (Ki) of **BIM 23052** for Human Somatostatin Receptors

Receptor Subtype	Ki (nM)	Reference(s)
sst1	31.3	
sst2	13.5	
sst3	>1000	
sst4	141	
sst5	7.3	

Table 2: Functional Activity (EC50/IC50) of **BIM 23052** at Human Somatostatin Receptors

Receptor Subtype	Assay Type	EC50/IC50 (nM)	Reference(s)
sst1	cAMP Inhibition	>1000	
sst2	cAMP Inhibition	~50 - 200	
sst3	cAMP Inhibition	>1000	
sst4	cAMP Inhibition	>1000	
sst5	cAMP Inhibition	~1 - 10	
sst5	Calcium Flux (with Gα16)	~5 - 20	

Note: Functional activity data can vary significantly depending on the cell line, expression level, and specific assay conditions.

## Experimental Protocols & Methodologies

This section provides detailed protocols for key experiments to validate the specificity of **BIM 23052**.

### Competitive Radioligand Binding Assay

This assay determines the binding affinity ( $K_i$ ) of **BIM 23052** for each somatostatin receptor subtype by measuring its ability to compete with a known radioligand.

Materials:

- Cell membranes from cells expressing a single sst subtype (e.g., CHO-K1 or HEK293 cells)
- Radioligand specific for the sst subtype (e.g., [ $^{125}$ I]-SRIF-14 or a subtype-selective radiolabeled antagonist)
- **BIM 23052**
- Non-specific binding control (e.g., a high concentration of unlabeled somatostatin-14)
- Assay buffer (e.g., 50 mM HEPES, 5 mM  $MgCl_2$ , 1 mM  $CaCl_2$ , 0.2% BSA, pH 7.4)
- 96-well plates
- Glass fiber filters
- Cell harvester
- Scintillation counter

Procedure:

- Prepare serial dilutions of **BIM 23052** in assay buffer.
- In a 96-well plate, add assay buffer, cell membranes, and either **BIM 23052**, buffer (for total binding), or the non-specific binding control.
- Add the radioligand to all wells at a final concentration close to its  $K_d$ .
- Incubate the plate at room temperature for 60-90 minutes to reach equilibrium.
- Rapidly filter the contents of each well through a glass fiber filter using a cell harvester.
- Wash the filters multiple times with ice-cold wash buffer.



- Measure the radioactivity retained on the filters using a scintillation counter.
- Calculate specific binding by subtracting non-specific binding from total binding.
- Plot the percentage of specific binding against the concentration of **BIM 23052** and fit the data to a one-site competition model to determine the IC50.
- Calculate the  $K_i$  value using the Cheng-Prusoff equation:  $K_i = IC_{50} / (1 + [L]/K_d)$ , where  $[L]$  is the concentration of the radioligand and  $K_d$  is its dissociation constant.

## cAMP Inhibition Assay

This functional assay measures the ability of **BIM 23052** to inhibit adenylyl cyclase and reduce cAMP levels in cells expressing a Gi-coupled somatostatin receptor.

Materials:

- Cells expressing a single sst subtype (e.g., CHO-K1 or HEK293)
- **BIM 23052**
- Forskolin (an adenylyl cyclase activator)
- IBMX (a phosphodiesterase inhibitor)
- cAMP assay kit (e.g., HTRF, AlphaScreen, or ELISA-based)
- 96- or 384-well plates

Procedure:

- Seed the cells in 96- or 384-well plates and allow them to attach overnight.
- Prepare serial dilutions of **BIM 23052**.
- Pre-incubate the cells with the different concentrations of **BIM 23052** in the presence of IBMX for 15-30 minutes.

- Stimulate the cells with a fixed concentration of forskolin (typically 1-10  $\mu\text{M}$ ) to induce cAMP production.
- Incubate for the recommended time according to the cAMP assay kit manufacturer's instructions.
- Lyse the cells and measure the intracellular cAMP levels using the detection reagents from the kit.
- Plot the cAMP levels against the concentration of **BIM 23052** and fit the data to a dose-response curve to determine the IC<sub>50</sub>.

## Receptor Internalization Assay using Flow Cytometry

This assay quantifies the internalization of a cell surface receptor upon agonist stimulation.

Materials:

- Cells expressing an epitope-tagged sst subtype (e.g., with a FLAG or HA tag at the N-terminus)
- **BIM 23052**
- Primary antibody against the epitope tag
- Fluorophore-conjugated secondary antibody
- Flow cytometer
- FACS tubes or 96-well V-bottom plates

Procedure:

- Incubate the cells with different concentrations of **BIM 23052** for a defined period (e.g., 30-60 minutes) at 37°C to allow for internalization.
- Place the cells on ice to stop the internalization process.
- Wash the cells with ice-cold FACS buffer (e.g., PBS with 2% FBS).

- Incubate the cells with the primary antibody against the epitope tag on ice for 30-60 minutes.
- Wash the cells to remove unbound primary antibody.
- Incubate the cells with the fluorophore-conjugated secondary antibody on ice, protected from light.
- Wash the cells to remove unbound secondary antibody.
- Resuspend the cells in FACS buffer and analyze them on a flow cytometer.
- Quantify the mean fluorescence intensity (MFI) of the cell population. A decrease in MFI indicates receptor internalization.
- Plot the percentage of remaining surface receptors (normalized to untreated cells) against the concentration of **BIM 23052** to determine the EC50 for internalization.

## Mandatory Visualizations

### Signaling Pathways

The following diagrams illustrate the primary signaling pathways activated by the five somatostatin receptor subtypes.

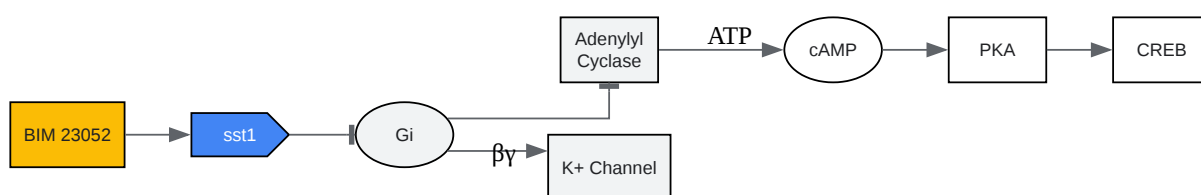

[Click to download full resolution via product page](#)

Caption: sst1 Signaling Pathway

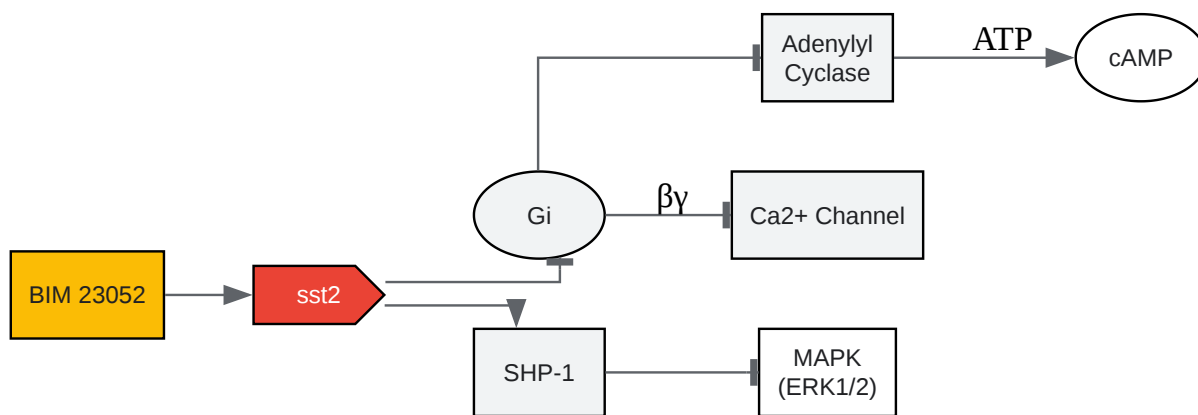

[Click to download full resolution via product page](#)

Caption: sst2 Signaling Pathway

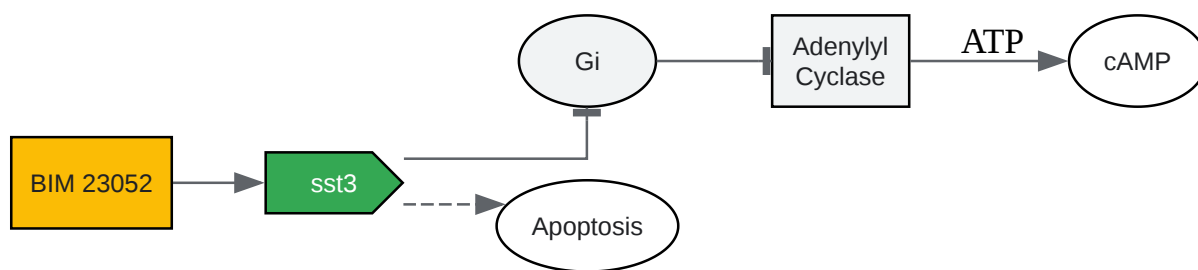

[Click to download full resolution via product page](#)

Caption: sst3 Signaling Pathway

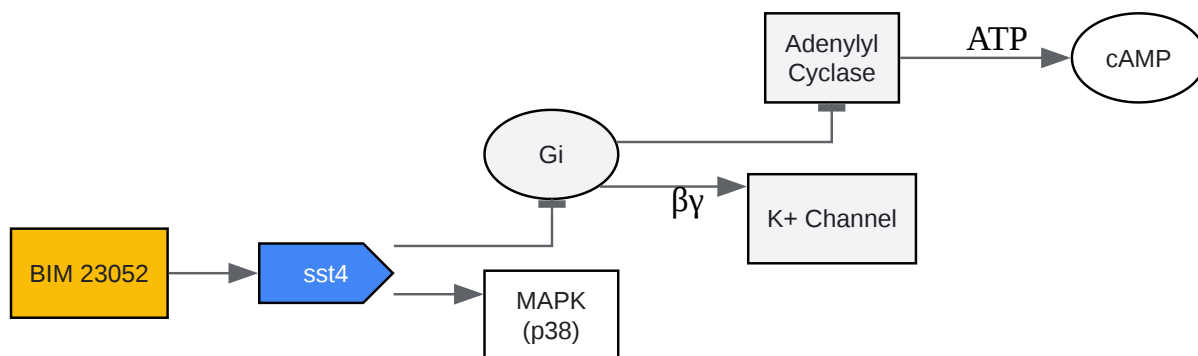

[Click to download full resolution via product page](#)

Caption: sst4 Signaling Pathway

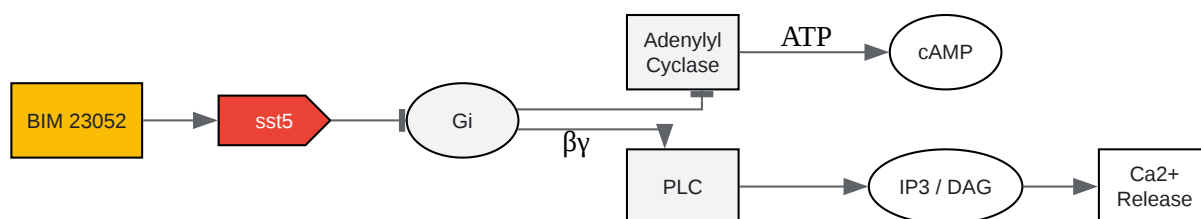

[Click to download full resolution via product page](#)

Caption: sst5 Signaling Pathway

## Experimental Workflow

The following diagram outlines a logical workflow for validating the specificity of **BIM 23052**.

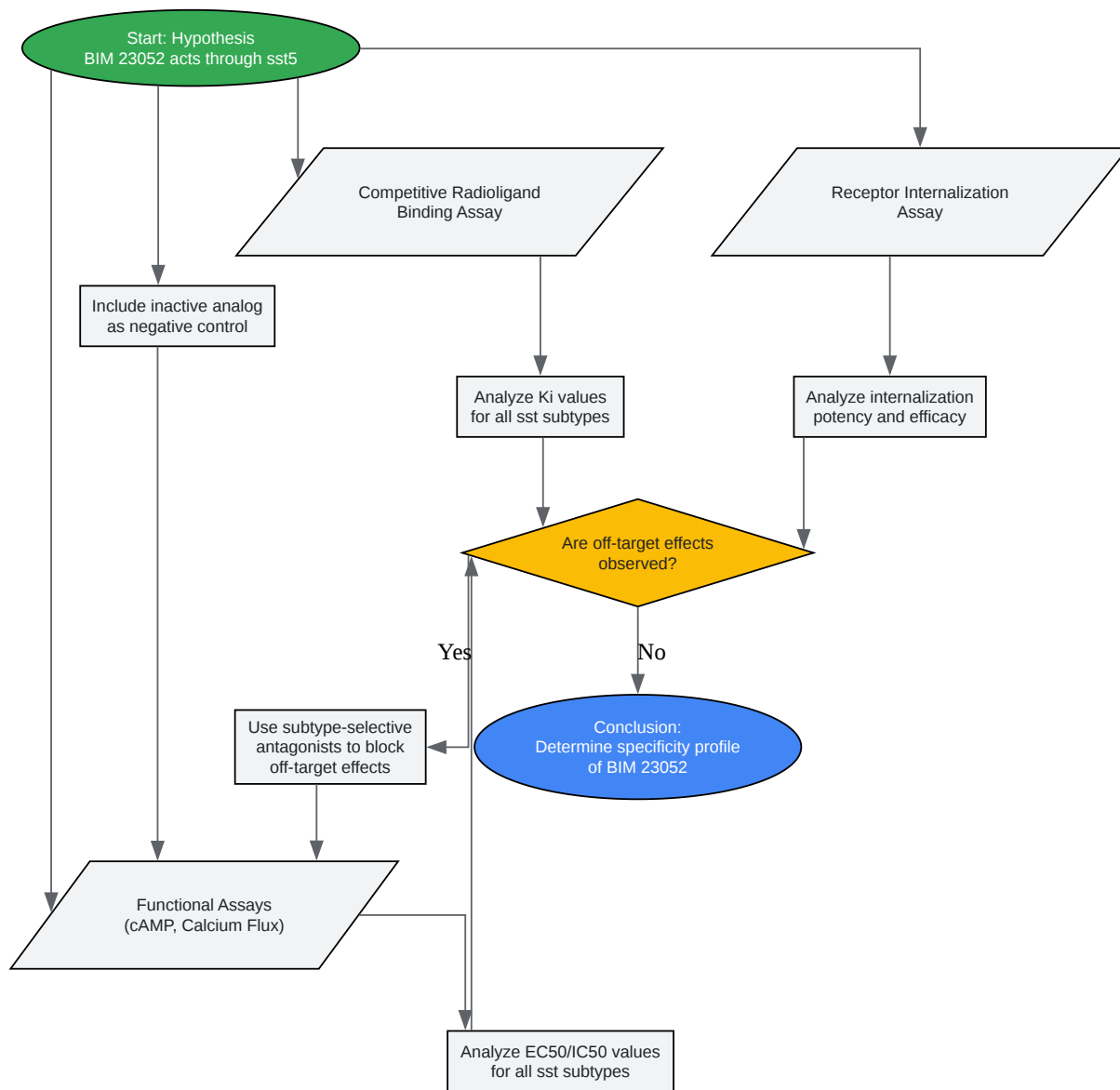

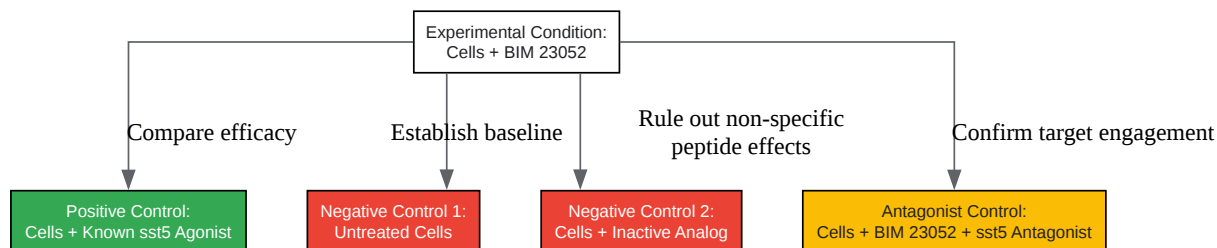

[Click to download full resolution via product page](#)

### Need Custom Synthesis?

BenchChem offers custom synthesis for rare earth carbides and specific isotopic labeling.

Email: [info@benchchem.com](mailto:info@benchchem.com) or [Request Quote Online](#).

## References

- 1. Synthesis, Antiproliferative Effect and In Silico LogP Prediction of BIM-23052 Analogs Containing Tyr Instead of Phe - PMC [pmc.ncbi.nlm.nih.gov]
- 2. medchemexpress.com [medchemexpress.com]
- 3. resources.revvity.com [resources.revvity.com]
- 4. Flow Cytometry Troubleshooting Guide: Novus Biologicals [novusbio.com]
- To cite this document: BenchChem. [Technical Support Center: Validating the Specificity of BIM 23052]. BenchChem, [2025]. [Online PDF]. Available at: [https://www.benchchem.com/product/b15617972#control-experiments-for-validating-bim-23052-s-specificity]

### Disclaimer & Data Validity:

The information provided in this document is for Research Use Only (RUO) and is strictly not intended for diagnostic or therapeutic procedures. While BenchChem strives to provide accurate protocols, we make no warranties, express or implied, regarding the fitness of this product for every specific experimental setup.

**Technical Support:** The protocols provided are for reference purposes. Unsure if this reagent suits your experiment? [[Contact our Ph.D. Support Team for a compatibility check](#)]

**Need Industrial/Bulk Grade?** [Request Custom Synthesis Quote](#)

## BenchChem

Our mission is to be the trusted global source of essential and advanced chemicals, empowering scientists and researchers to drive progress in science and industry.

### Contact

Address: 3281 E Guasti Rd

Ontario, CA 91761, United States

Phone: (601) 213-4426

Email: [info@benchchem.com](mailto:info@benchchem.com)