

Technical Support Center: Troubleshooting Darifenacin Off-Target Effects

Author: BenchChem Technical Support Team. **Date:** December 2025

Compound of Interest

Compound Name: Tarafenacin D-tartrate

Cat. No.: B611152

[Get Quote](#)

This technical support center provides guidance for researchers, scientists, and drug development professionals who are using Darifenacin (formerly referred to as **Tarafenacin D-tartrate** in the user query) and encountering potential off-target effects in their experiments. The following information is intended to help troubleshoot unexpected results and differentiate between on-target and off-target pharmacological activities.

Frequently Asked Questions (FAQs) and Troubleshooting Guides

Q1: My in vivo animal model is exhibiting excessive anticholinergic side effects (e.g., severe dry mouth, constipation, blurred vision) at a dose that is supposed to be selective for the M3 receptor. Is this an off-target effect?

A1: While Darifenacin is selective for the M3 muscarinic receptor, it is not entirely specific and can interact with other muscarinic receptor subtypes, particularly at higher concentrations.[1] The observed side effects are characteristic of systemic anticholinergic activity, which can result from the blockade of M1, M2, and M3 receptors in various tissues.[2]

Troubleshooting Steps:

- **Dose-Response Analysis:** Conduct a dose-response study to determine if the side effects are dose-dependent. A steep dose-response curve for the side effects may suggest off-target activity at higher concentrations.

- **Pharmacokinetic Analysis:** Analyze the plasma and tissue concentrations of Darifenacin to ensure they are within the expected therapeutic range for M3 receptor antagonism. Higher than expected concentrations could lead to engagement of other muscarinic receptor subtypes.
- **Selective Antagonist Comparison:** Compare the in vivo effects of Darifenacin with a non-selective muscarinic antagonist like atropine and another M3-selective antagonist. This can help to dissect the contribution of M3 versus other muscarinic receptor blockades to the observed effects.
- **In Vitro Tissue Bath Studies:** Use isolated tissues known to be rich in specific muscarinic receptor subtypes (e.g., rabbit vas deferens for M1, guinea pig atria for M2, guinea pig ileum for M3) to determine the functional potency of Darifenacin at each subtype.

Q2: In my cell-based assay using a cell line that only expresses the recombinant M3 receptor, I am observing a response that is not consistent with simple competitive antagonism. What could be the cause?

A2: Unexpected behavior in a well-defined in vitro system could be due to several factors:

Troubleshooting Steps:

- **Receptor Expression and Functionality:**
 - **Verify Receptor Expression:** Confirm the expression level and localization of the M3 receptor in your cell line using techniques like Western blot, ELISA, or immunofluorescence.
 - **Confirm Agonist Response:** Ensure that your cells respond robustly and consistently to a known muscarinic agonist (e.g., carbachol, acetylcholine).
- **Assay Conditions:**
 - **Ligand Stability:** Ensure the stability of Darifenacin in your assay medium over the course of the experiment.

- Kinetic Artifacts: Consider the binding kinetics of Darifenacin. A slow binding antagonist might appear non-competitive in assays with short incubation times.[3]
- Biased Signaling: Investigate the possibility of biased agonism/antagonism. Darifenacin might be acting as an antagonist for one signaling pathway (e.g., Gq-mediated calcium mobilization) but as an agonist or partial agonist for another (e.g., β -arrestin recruitment).[4] Functional assays that measure different downstream signaling events (e.g., calcium flux, cAMP production, ERK phosphorylation) can help to explore this.[4][5]

Q3: My results suggest that Darifenacin is interacting with a non-muscarinic receptor. How can I investigate this?

A3: While Darifenacin is known for its activity at muscarinic receptors, off-target interactions with other receptors, ion channels, or enzymes are possible, especially at higher concentrations.

Troubleshooting Steps:

- Broad Panel Screening: The most comprehensive approach is to screen Darifenacin against a broad panel of receptors, ion channels, and enzymes. Commercial services are available for this purpose.
- Literature Review: Conduct a thorough literature search for any reported interactions of Darifenacin or structurally similar compounds with other targets.
- Competitive Binding Assays: If you have a hypothesis about a specific off-target receptor, perform competitive binding assays using a radiolabeled ligand for that receptor to determine Darifenacin's binding affinity.
- Functional Assays for a Hypothesized Off-Target: If binding is confirmed, conduct a functional assay to determine if Darifenacin acts as an antagonist, agonist, or partial agonist at the off-target receptor.

Data Presentation

Table 1: Binding Affinities of Darifenacin for Human Muscarinic Receptor Subtypes

This table summarizes the binding affinities of Darifenacin for the five human muscarinic receptor subtypes (M1-M5). The data is presented as pKi values, which are the negative logarithm of the inhibition constant (Ki). A higher pKi value indicates a higher binding affinity.

| Receptor Subtype | pKi | Selectivity Ratio (vs. M3) |
|------------------|-----|----------------------------|
| M1 | 8.2 | 8-fold lower than M3 |
| M2 | 7.4 | 50-fold lower than M3 |
| M3 | 9.1 | - |
| M4 | 7.3 | 63-fold lower than M3 |
| M5 | 8.0 | 12-fold lower than M3 |

Note: Selectivity ratios are approximate and calculated from the pKi values.

Experimental Protocols

1. Radioligand Competition Binding Assay

Objective: To determine the binding affinity (Ki) of Darifenacin for a specific muscarinic receptor subtype.

Methodology:

- **Preparation of Cell Membranes:** Homogenize cells or tissues expressing the target muscarinic receptor subtype in a suitable buffer (e.g., Tris-HCl) and prepare a membrane fraction by centrifugation.
- **Assay Setup:** In a 96-well plate, add the cell membranes, a constant concentration of a radiolabeled muscarinic antagonist (e.g., [3H]-N-methylscopolamine), and varying concentrations of unlabeled Darifenacin.
- **Incubation:** Incubate the plate at room temperature for a sufficient time to reach binding equilibrium.

- Separation of Bound and Free Radioligand: Rapidly filter the contents of each well through a glass fiber filter to separate the membrane-bound radioligand from the free radioligand.
- Quantification: Measure the radioactivity retained on the filters using a scintillation counter.
- Data Analysis: Plot the percentage of specific binding against the logarithm of the Darifenacin concentration. Fit the data to a one-site competition model to determine the IC50 value. Calculate the Ki value using the Cheng-Prusoff equation.

2. In Vitro Calcium Mobilization Assay

Objective: To assess the functional antagonist activity of Darifenacin at the M3 receptor.

Methodology:

- Cell Culture: Culture a cell line stably expressing the human M3 muscarinic receptor (e.g., CHO-M3 or HEK-M3 cells).
- Cell Loading: Load the cells with a calcium-sensitive fluorescent dye (e.g., Fura-2 AM or Fluo-4 AM).
- Compound Treatment: Pre-incubate the cells with varying concentrations of Darifenacin for a specific period.
- Agonist Stimulation: Add a known muscarinic agonist (e.g., carbachol) at a concentration that elicits a submaximal response (EC80).
- Fluorescence Measurement: Measure the change in intracellular calcium concentration by monitoring the fluorescence intensity using a plate reader or a fluorescence microscope.
- Data Analysis: Plot the agonist-induced calcium response as a percentage of the control response (agonist alone) against the logarithm of the Darifenacin concentration. Fit the data to a sigmoidal dose-response curve to determine the IC50 value.

Mandatory Visualization

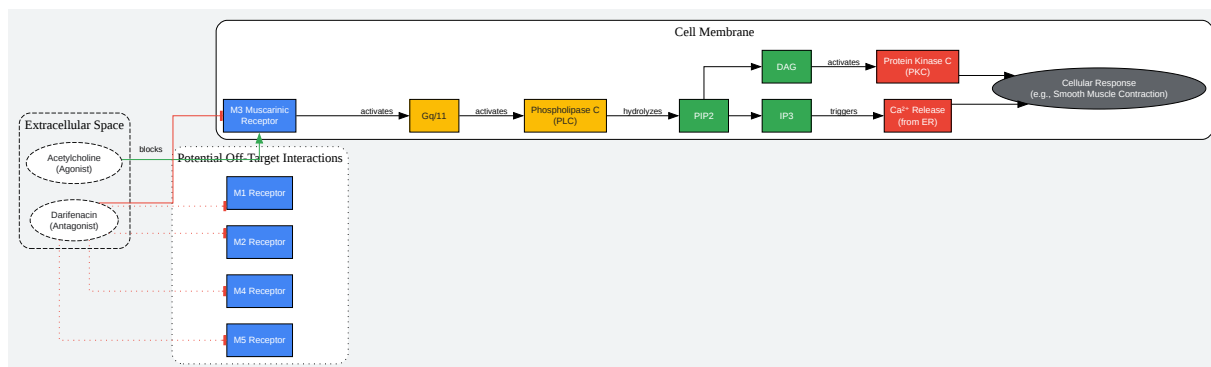

[Click to download full resolution via product page](#)

Caption: Darifenacin signaling pathway at the M3 muscarinic receptor.

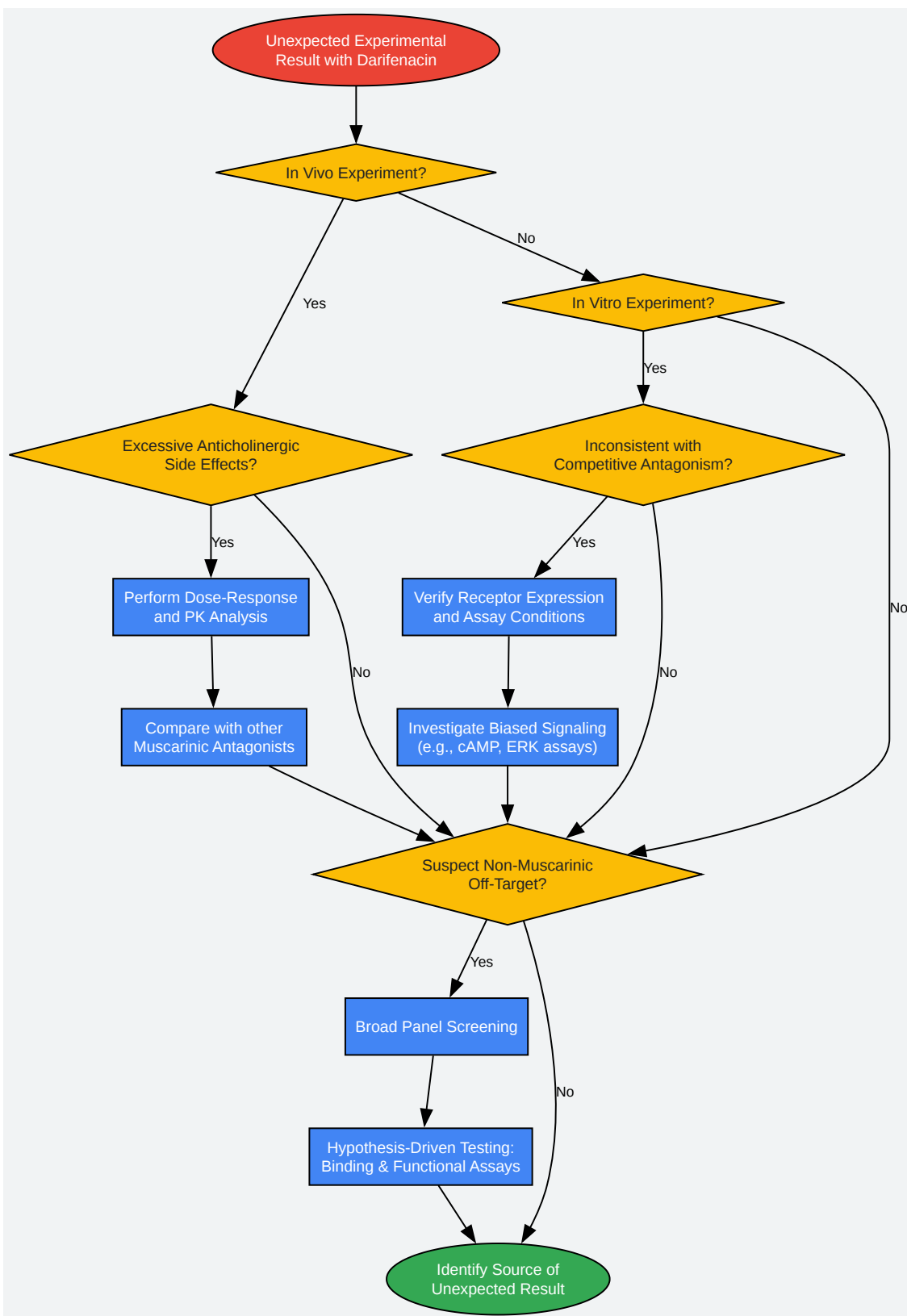

[Click to download full resolution via product page](#)

Caption: Troubleshooting workflow for Darifenacin off-target effects.

Need Custom Synthesis?

BenchChem offers custom synthesis for rare earth carbides and specific isotopic labeling.

Email: info@benchchem.com or [Request Quote Online](#).

References

- 1. Muscarinic Receptors as Model Targets and Antitargets for Structure-Based Ligand Discovery - PMC [pmc.ncbi.nlm.nih.gov]
- 2. Muscarinic Antagonists - StatPearls - NCBI Bookshelf [ncbi.nlm.nih.gov]
- 3. pubs.acs.org [pubs.acs.org]
- 4. Teaching an Old Drug New Tricks: Agonism, Antagonism, and Biased Signaling of Pilocarpine through M3 Muscarinic Acetylcholine Receptor - PubMed [pubmed.ncbi.nlm.nih.gov]
- 5. aacrjournals.org [aacrjournals.org]
- To cite this document: BenchChem. [Technical Support Center: Troubleshooting Darifenacin Off-Target Effects]. BenchChem, [2025]. [Online PDF]. Available at: [https://www.benchchem.com/product/b611152#troubleshooting-tarafenacin-d-tartrate-off-target-effects]

Disclaimer & Data Validity:

The information provided in this document is for Research Use Only (RUO) and is strictly not intended for diagnostic or therapeutic procedures. While BenchChem strives to provide accurate protocols, we make no warranties, express or implied, regarding the fitness of this product for every specific experimental setup.

Technical Support: The protocols provided are for reference purposes. Unsure if this reagent suits your experiment? [[Contact our Ph.D. Support Team for a compatibility check](#)]

Need Industrial/Bulk Grade? [Request Custom Synthesis Quote](#)

BenchChem

Our mission is to be the trusted global source of essential and advanced chemicals, empowering scientists and researchers to drive progress in science and industry.

Contact

Address: 3281 E Guasti Rd
Ontario, CA 91761, United States
Phone: (601) 213-4426
Email: info@benchchem.com