

# Technical Support Center: TG100-115 In Vivo Efficacy

**Author:** BenchChem Technical Support Team. **Date:** December 2025

## Compound of Interest

Compound Name: TG100-115

Cat. No.: B1684651

[Get Quote](#)

This technical support center provides troubleshooting guidance and frequently asked questions (FAQs) to assist researchers, scientists, and drug development professionals in optimizing the in vivo efficacy of **TG100-115**.

## Frequently Asked Questions (FAQs)

Q1: What is the primary mechanism of action of **TG100-115**?

A1: **TG100-115** is a potent and selective dual inhibitor of phosphoinositide 3-kinase gamma (PI3K $\gamma$ ) and delta (PI3K $\delta$ ) with IC<sub>50</sub> values of 83 nM and 235 nM, respectively.[1][2][3][4] It shows significantly less activity against PI3K $\alpha$  and PI3K $\beta$  isoforms.[1][2][3][4] More recently, **TG100-115** has also been identified as a potent inhibitor of the transient receptor potential melastatin 7 (TRPM7) kinase.[5][6][7][8]

Q2: What are the reported in vivo applications of **TG100-115**?

A2: **TG100-115** has been investigated in various preclinical models for conditions including:

- Myocardial ischemia/reperfusion injury[1][7][9]
- Asthma and Chronic Obstructive Pulmonary Disease (COPD)[9][10]
- Inflammation and edema[1][2][7][9]
- Glioblastoma[5]

- Breast cancer metastasis[6][7]

Q3: What is the solubility of **TG100-115**?

A3: **TG100-115** is soluble in DMSO but insoluble in water and ethanol.[1][4] For in vivo use, specific formulations are required.

Q4: How should I prepare **TG100-115** for in vivo administration?

A4: Due to its poor water solubility, a common formulation involves dissolving **TG100-115** in a vehicle such as a mixture of DMSO, PEG300, and water.[1] One suggested protocol for a 1 mL working solution involves adding 50  $\mu$ L of an 8 mg/mL DMSO stock solution to 300  $\mu$ L of PEG300, mixing until clear, and then adding 650  $\mu$ L of ddH<sub>2</sub>O.[1] This solution should be used immediately.[1] For oral administration, a homogeneous suspension in CMC-NA has also been mentioned.[1]

Q5: What are typical dosage ranges for **TG100-115** in animal models?

A5: Effective doses in rodent and porcine models have been reported to range from 0.5 mg/kg to 10 mg/kg.[1][2][3] In some studies, a dose as low as 0.5 mg/kg has shown significant efficacy in reducing infarct size in myocardial infarction models.[2][3]

Q6: What routes of administration have been used for **TG100-115** in vivo?

A6: Both intravenous (i.v.) injection and aerosolized inhalation have been successfully used.[1][10] The choice of administration route depends on the disease model. For example, aerosolized delivery has been shown to be effective in lung-specific inflammatory models like asthma, achieving high local concentrations with minimal systemic exposure.[10]

## Troubleshooting Guide

Issue	Potential Cause	Recommended Solution
Poor or inconsistent efficacy	Suboptimal formulation: TG100-115 may be precipitating out of solution.	Prepare the formulation fresh before each use. <sup>[1]</sup> Ensure the DMSO stock is fully dissolved before adding other components. Consider alternative formulation strategies if precipitation is observed.
Inadequate dosage: The dose may be too low for the specific animal model or disease state.	Conduct a dose-response study to determine the optimal dose, starting from reported effective ranges (0.5-10 mg/kg). <sup>[2][3]</sup>	
Ineffective route of administration: The drug may not be reaching the target tissue at a sufficient concentration.	For localized diseases like asthma, consider local delivery routes such as aerosolization. <sup>[10]</sup> For systemic effects, intravenous administration is a common choice. <sup>[1]</sup>	
Toxicity or adverse events	High dosage: The administered dose may be too high.	Reduce the dosage and perform a dose-escalation study to find the maximum tolerated dose (MTD).
Vehicle toxicity: The vehicle used for formulation may be causing adverse effects.	Run a vehicle-only control group to assess the toxicity of the formulation vehicle itself.	
Difficulty dissolving the compound	Poor solubility: TG100-115 is known to be insoluble in aqueous solutions. <sup>[1]</sup>	Use a co-solvent system such as DMSO and PEG300. <sup>[1]</sup> Gentle warming (to 37°C) and sonication can aid in dissolution. <sup>[11]</sup>

Inconsistent results between experiments	Variability in formulation preparation: Inconsistent preparation can lead to different effective concentrations.	Standardize the formulation protocol, ensuring precise measurements and mixing procedures. Prepare a fresh batch for each experiment. <sup>[1]</sup>
Animal-to-animal variability: Biological differences can lead to varied responses.	Increase the number of animals per group to improve statistical power. Ensure animals are of similar age and weight.	

## Quantitative Data Summary

Table 1: IC50 Values of **TG100-115** for PI3K Isoforms

Kinase	IC50 (nM)
PI3K $\gamma$	83 <sup>[1][2][3]</sup>
PI3K $\delta$	235 <sup>[1][2][3]</sup>
PI3K $\alpha$	>1,000 (1,300) <sup>[1][12]</sup>
PI3K $\beta$	>1,000 (1,200) <sup>[1][12]</sup>
TRPM7	1,070 <sup>[7]</sup>

Table 2: In Vivo Dosing and Efficacy of **TG100-115** in a Myocardial Infarction Model

Animal Model	Dose	Administration Route	Key Finding
Porcine	0.5 mg/kg	Intravenous	35% reduction in infarct size as a percentage of the area at risk.[7]
Rodent	0.5 mg/kg	Intravenous	Maximal efficacy in reducing infarct size by $\geq 40\%$ .[11]

## Experimental Protocols

### PI3K Kinase Assay Protocol

This protocol is adapted from published methodologies.[1][11]

- Prepare a reaction buffer containing 20 mM Tris, 4 mM MgCl<sub>2</sub>, and 10 mM NaCl at pH 7.4.
- In a 96-well plate, aliquot 40  $\mu$ L of the reaction buffer containing 50  $\mu$ M D-myo-phosphatidylinositol 4,5-bisphosphate substrate and the desired PI3K isoform (250-500 ng/well).
- Add 2.5  $\mu$ L of **TG100-115** from a DMSO stock to achieve final concentrations ranging from 1 nM to 100  $\mu$ M.
- Initiate the kinase reaction by adding 10  $\mu$ L of ATP to a final concentration of 3  $\mu$ M.
- Incubate for 90 minutes to allow for linear kinetics.
- Add 50  $\mu$ L of a suitable reagent (e.g., Kinase-Glo®) to quantify the remaining ATP.
- Measure the luminescence to determine the kinase activity.

## Visualizations

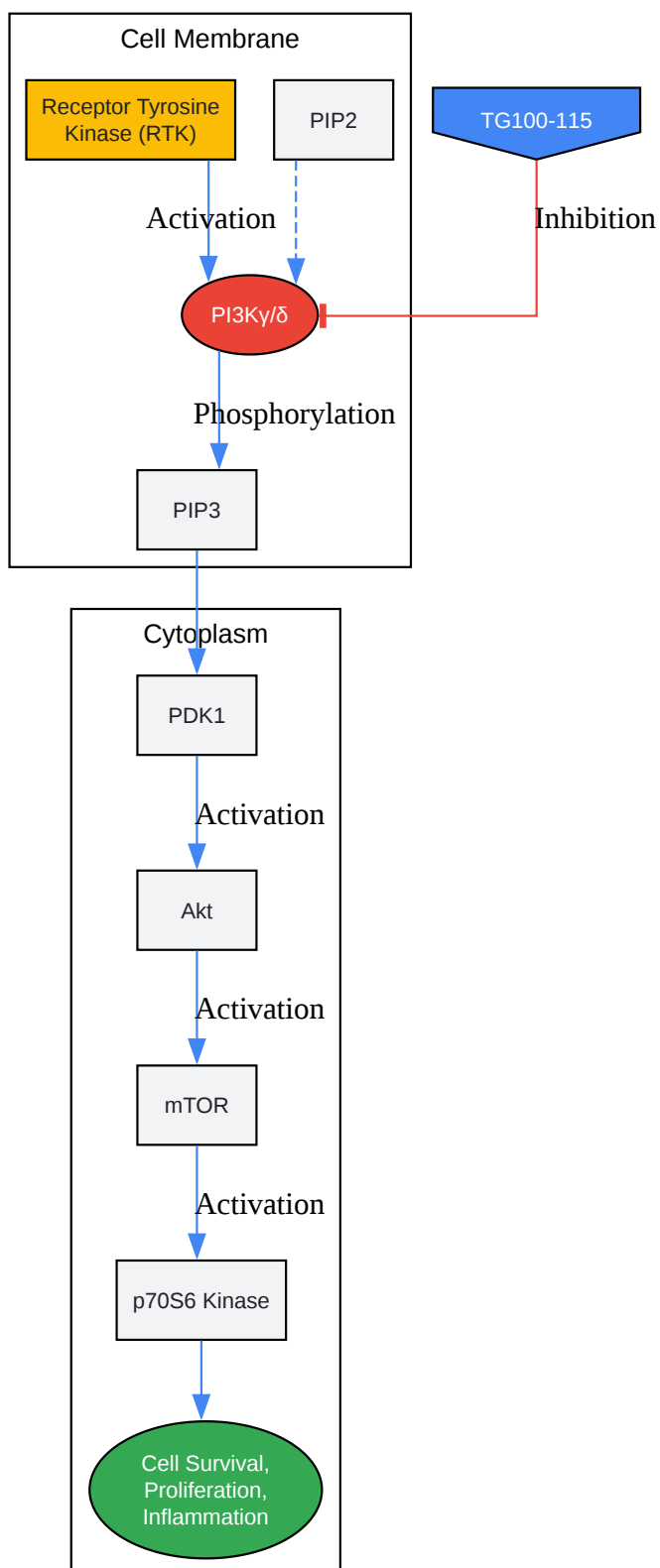

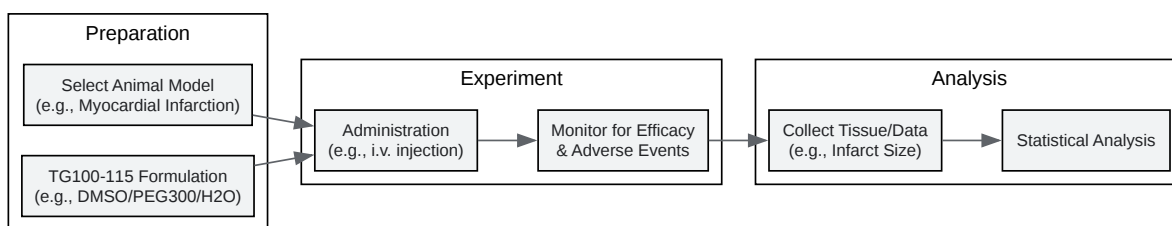
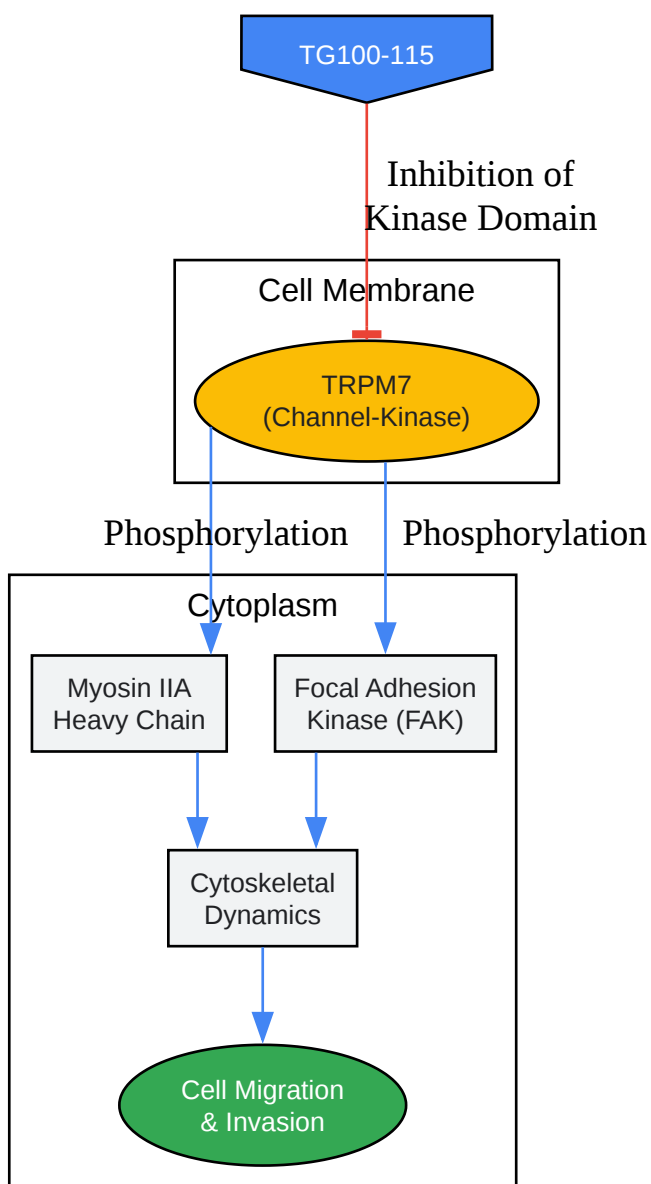

[Click to download full resolution via product page](#)

### Need Custom Synthesis?

BenchChem offers custom synthesis for rare earth carbides and specific isotopic labeling.

Email: [info@benchchem.com](mailto:info@benchchem.com) or [Request Quote Online](#).

## References

- 1. selleckchem.com [selleckchem.com]
- 2. medchemexpress.com [medchemexpress.com]
- 3. TG100-115 | CAS#:677297-51-7 | Chemsrce [chemsrc.com]
- 4. medkoo.com [medkoo.com]
- 5. In vitro suppression of glioblastoma cell functions by TG100-115, a transient receptor potential melastatin 7 kinase inhibitor [accscience.com]
- 6. Identification of TG100-115 as a new and potent TRPM7 kinase inhibitor, which suppresses breast cancer cell migration and invasion - PubMed [pubmed.ncbi.nlm.nih.gov]
- 7. caymanchem.com [caymanchem.com]
- 8. TG-100-115 | Ligand page | IUPHAR/BPS Guide to PHARMACOLOGY [guidetopharmacology.org]
- 9. TG100-115 - LKT Labs [lktlabs.com]
- 10. Aerosolized phosphoinositide 3-kinase gamma/delta inhibitor TG100-115 [3-[2,4-diamino-6-(3-hydroxyphenyl)pteridin-7-yl]phenol] as a therapeutic candidate for asthma and chronic obstructive pulmonary disease - PubMed [pubmed.ncbi.nlm.nih.gov]
- 11. glpbio.com [glpbio.com]
- 12. TG100-115产品说明书 [selleck.cn]
- To cite this document: BenchChem. [Technical Support Center: TG100-115 In Vivo Efficacy]. BenchChem, [2025]. [Online PDF]. Available at: [https://www.benchchem.com/product/b1684651#improving-the-efficacy-of-tg100-115-in-vivo]

---

### Disclaimer & Data Validity:



The information provided in this document is for Research Use Only (RUO) and is strictly not intended for diagnostic or therapeutic procedures. While BenchChem strives to provide accurate protocols, we make no warranties, express or implied, regarding the fitness of this product for every specific experimental setup.

**Technical Support:** The protocols provided are for reference purposes. Unsure if this reagent suits your experiment? [[Contact our Ph.D. Support Team for a compatibility check](#)]

**Need Industrial/Bulk Grade?** [Request Custom Synthesis Quote](#)

## BenchChem

Our mission is to be the trusted global source of essential and advanced chemicals, empowering scientists and researchers to drive progress in science and industry.

### Contact

Address: 3281 E Guasti Rd  
Ontario, CA 91761, United States  
Phone: (601) 213-4426  
Email: [info@benchchem.com](mailto:info@benchchem.com)