

Technical Support Center: Stabilizing Bryodulcosigenin in Solution

Author: BenchChem Technical Support Team. **Date:** December 2025

Compound of Interest

Compound Name: *Bryodulcosigenin*

Cat. No.: *B150003*

[Get Quote](#)

This technical support center provides researchers, scientists, and drug development professionals with essential guidance on stabilizing **Bryodulcosigenin** in solution for experimental use. The following troubleshooting guides and frequently asked questions (FAQs) address common challenges to ensure the integrity and reproducibility of your results.

Frequently Asked Questions (FAQs)

Q1: What is the recommended solvent for dissolving **Bryodulcosigenin**?

A1: For most in vitro experiments, Dimethyl Sulfoxide (DMSO) is the recommended solvent for creating stock solutions of **Bryodulcosigenin**.^[1] It is capable of dissolving a wide range of polar and nonpolar compounds.^[1] For in vivo studies, a common practice is to first dissolve the compound in a small amount of DMSO and then dilute it with a pharmaceutically acceptable vehicle such as saline, phosphate-buffered saline (PBS), or a solution containing a solubilizing agent like Tween 80 or Cremophor EL.

Q2: What are the optimal storage conditions for **Bryodulcosigenin** solutions?

A2: To minimize degradation, **Bryodulcosigenin** solutions should be stored under the following conditions:

- **Temperature:** For short-term storage (1-2 weeks), refrigeration at 2-8°C is recommended. For long-term storage, freezing at -20°C or -80°C is ideal.

- Light: Protect solutions from light by using amber vials or by wrapping the container in aluminum foil.
- Air: For sensitive compounds, it may be beneficial to purge the vial with an inert gas like nitrogen or argon before sealing to prevent oxidation.

Q3: How can I avoid precipitation of **Bryodulcosigenin** in my aqueous experimental media?

A3: Precipitation in aqueous media is a common issue with hydrophobic compounds like **Bryodulcosigenin**. Here are some strategies to prevent this:

- Use a Co-solvent: Ensure the final concentration of the organic solvent (e.g., DMSO) in your aqueous media is kept low, typically below 1%, to avoid solvent-induced artifacts, but high enough to maintain solubility.
- Incorporate a Surfactant: The addition of a non-ionic surfactant, such as Tween 80 or Pluronic F-68, at a low concentration (e.g., 0.1-1%) can help to maintain the solubility of the compound.
- pH Adjustment: The solubility of some compounds is pH-dependent. While specific data for **Bryodulcosigenin** is limited, you can empirically test a narrow pH range around the physiological pH of your experiment to see if it improves solubility without affecting the compound's activity or your experimental system.

Troubleshooting Guides

Issue 1: Inconsistent experimental results or loss of compound activity.

This issue often points to the degradation of **Bryodulcosigenin** in your stock or working solutions.

Potential Cause	Troubleshooting Step	Recommended Action
Hydrolysis	Monitor the pH of your solutions. Acidic or basic conditions can lead to the hydrolysis of ester or glycosidic bonds. Studies on other cucurbitane-type triterpenoids have shown transformations under acidic conditions.[2]	Maintain the pH of your solutions within a neutral range (pH 6-8) unless your experimental protocol requires otherwise. Prepare fresh solutions before each experiment.
Oxidation	The presence of dissolved oxygen can lead to oxidative degradation, especially for compounds with sensitive functional groups.	De-gas your solvents and buffers. Consider adding a small amount of an antioxidant, such as ascorbic acid or butylated hydroxytoluene (BHT), if compatible with your experimental system.
Photodegradation	Exposure to light, particularly UV light, can cause degradation of light-sensitive compounds.	Always store and handle Bryodulcosigenin solutions in light-protected containers.
Repeated Freeze-Thaw Cycles	Repeatedly freezing and thawing stock solutions can lead to compound degradation and precipitation.	Aliquot your stock solution into single-use vials to avoid multiple freeze-thaw cycles.

Issue 2: Precipitation of the compound during the experiment.

Precipitation can lead to a lower effective concentration of the compound and inaccurate results.

Potential Cause	Troubleshooting Step	Recommended Action
Poor Aqueous Solubility	The compound may be crashing out of solution when diluted into an aqueous buffer from an organic stock.	Decrease the final concentration of the compound. Increase the concentration of the co-solvent (e.g., DMSO) slightly, ensuring it remains within a non-toxic range for your cells or animal model. Add a biocompatible surfactant to your media.
Interaction with Media Components	Components of your cell culture media or buffer (e.g., proteins in serum) may interact with the compound, causing it to precipitate.	Perform a solubility test of Bryodulcosigenin in your specific experimental media. If precipitation occurs, consider using a serum-free media for the duration of the treatment or a different solubilizing agent.
Temperature Changes	A decrease in temperature can reduce the solubility of some compounds.	Ensure all solutions are at the experimental temperature before mixing.

Experimental Protocols

Protocol 1: Preparation of **Bryodulcosigenin** Stock Solution

- **Weighing:** Accurately weigh the required amount of **Bryodulcosigenin** powder in a sterile microcentrifuge tube.
- **Dissolution:** Add the appropriate volume of sterile, anhydrous DMSO to achieve the desired stock concentration (e.g., 10 mM).
- **Solubilization:** Vortex the solution for 1-2 minutes until the compound is completely dissolved. Gentle warming in a 37°C water bath may be used if necessary, but avoid excessive heat.

- Storage: Aliquot the stock solution into single-use, light-protected vials and store at -20°C or -80°C.

Protocol 2: Preparation of Working Solution for In Vitro Assays

- Thawing: Thaw a single aliquot of the **Bryodulcosigenin** stock solution at room temperature.
- Dilution: Serially dilute the stock solution in your cell culture medium or assay buffer to the final desired concentrations. Ensure thorough mixing after each dilution step.
- Final DMSO Concentration: Calculate the final percentage of DMSO in your working solutions and ensure it is consistent across all experimental and control groups and is at a non-toxic level (typically <0.5%).
- Use Immediately: Use the freshly prepared working solutions for your experiment immediately to minimize degradation.

Visualizations

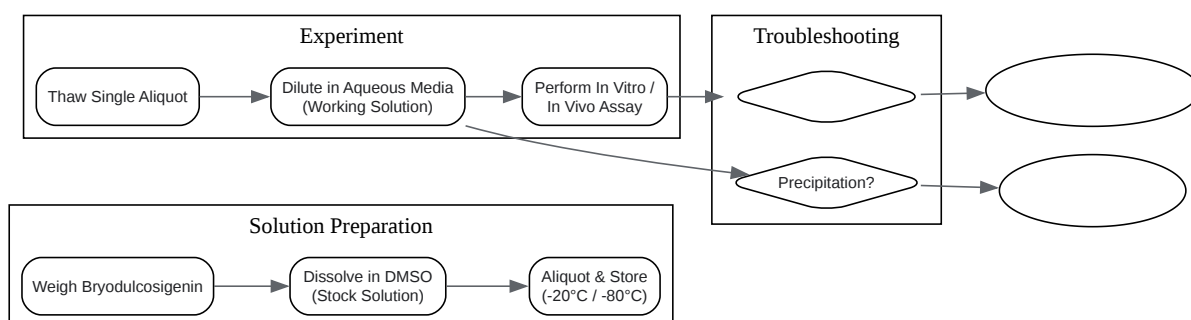

[Click to download full resolution via product page](#)

Caption: Experimental workflow for preparing and using **Bryodulcosigenin** solutions.

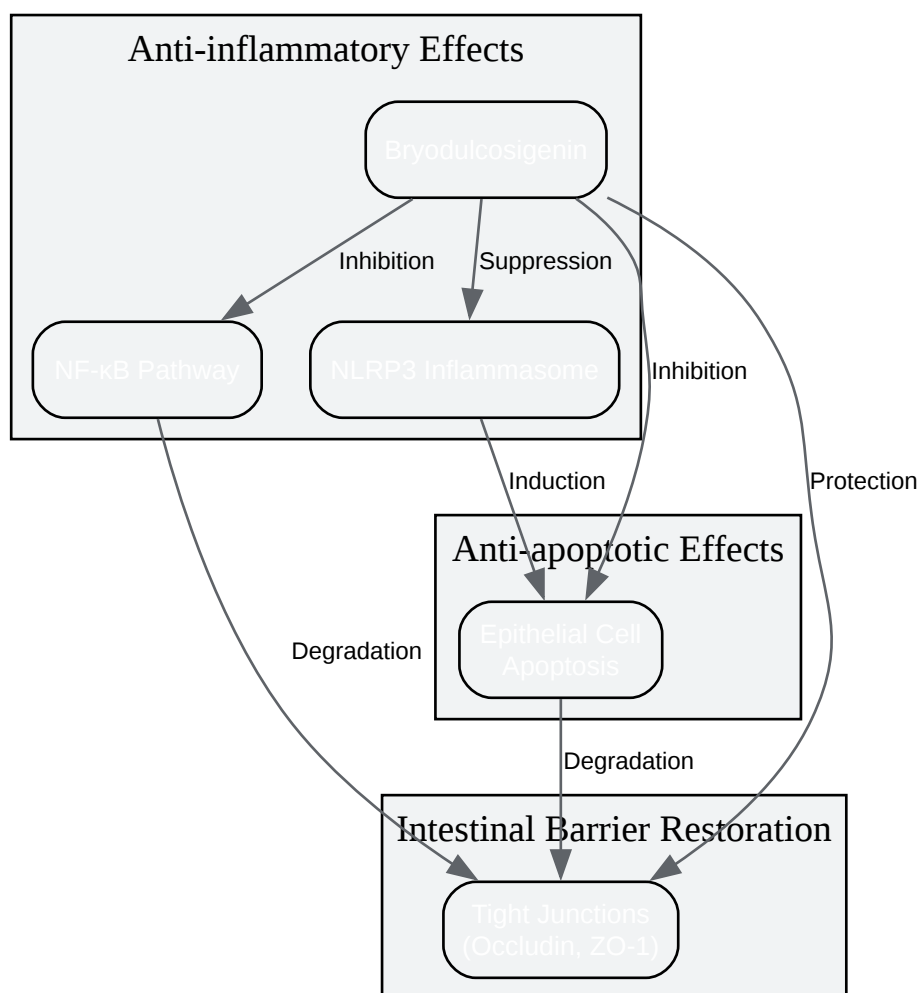

[Click to download full resolution via product page](#)

Caption: Postulated signaling pathways affected by **Bryodulcosigenin**.^{[3][4]}

Need Custom Synthesis?

BenchChem offers custom synthesis for rare earth carbides and specific isotopic labeling.

Email: info@benchchem.com or [Request Quote Online](#).

References

- 1. Dimethyl sulfoxide - Wikipedia [en.wikipedia.org]

- 2. Rethinking the Cucurbitane-Type Triterpenoid Profile of Bitter Gourd (*Momordica charantia* L.): The Chemical Transformation of Momordicine I in Solution - PubMed [pubmed.ncbi.nlm.nih.gov]
- 3. Bryodulcosigenin a natural cucurbitane-type triterpenoid attenuates dextran sulfate sodium (DSS)-induced colitis in mice - PubMed [pubmed.ncbi.nlm.nih.gov]
- 4. Anti-inflammatory and neuroprotective effect of bryodulcosigenin against cerebral ischemia/reperfusion injury via modulation of inflammatory signaling pathways - PubMed [pubmed.ncbi.nlm.nih.gov]
- To cite this document: BenchChem. [Technical Support Center: Stabilizing Bryodulcosigenin in Solution]. BenchChem, [2025]. [Online PDF]. Available at: [https://www.benchchem.com/product/b150003#stabilizing-bryodulcosigenin-in-solution-for-experiments]

Disclaimer & Data Validity:

The information provided in this document is for Research Use Only (RUO) and is strictly not intended for diagnostic or therapeutic procedures. While BenchChem strives to provide accurate protocols, we make no warranties, express or implied, regarding the fitness of this product for every specific experimental setup.

Technical Support: The protocols provided are for reference purposes. Unsure if this reagent suits your experiment? [[Contact our Ph.D. Support Team for a compatibility check](#)]

Need Industrial/Bulk Grade? [Request Custom Synthesis Quote](#)

BenchChem

Our mission is to be the trusted global source of essential and advanced chemicals, empowering scientists and researchers to drive progress in science and industry.

Contact

Address: 3281 E Guasti Rd
Ontario, CA 91761, United States
Phone: (601) 213-4426
Email: info@benchchem.com