

# Technical Support Center: Scaling Up Reactions with Tetrabutylammonium Cyanide

**Author:** BenchChem Technical Support Team. **Date:** December 2025

## Compound of Interest

Compound Name: Tetrabutylammonium cyanide

Cat. No.: B079372

[Get Quote](#)

This guide provides troubleshooting advice, frequently asked questions (FAQs), and detailed protocols for researchers, scientists, and drug development professionals who are scaling up chemical reactions involving **tetrabutylammonium cyanide** (TBACN).

## Frequently Asked Questions (FAQs)

Q1: What is **tetrabutylammonium cyanide** and why is it used in organic synthesis?

**Tetrabutylammonium cyanide** (TBACN) is a quaternary ammonium salt consisting of a tetrabutylammonium cation and a cyanide anion.<sup>[1]</sup> It is a white to off-white solid typically soluble in polar organic solvents like acetone, acetonitrile, and dimethylformamide (DMF).<sup>[1]</sup> Its primary use is as a source of soluble cyanide ions in organic solvents for reactions such as nucleophilic substitutions and cyanosilylations.<sup>[1][2][3]</sup> Unlike simple alkali metal cyanides (e.g., NaCN, KCN), TBACN's lipophilic cation enhances its solubility in organic media, often accelerating reaction rates and improving yields.<sup>[1][4]</sup>

Q2: What are the critical safety precautions for handling TBACN at scale?

Due to the presence of the cyanide ion, TBACN is highly toxic if inhaled, ingested, or absorbed through the skin.<sup>[1][5]</sup> When scaling up, the risks are magnified.

- **Engineering Controls:** Always handle TBACN in a well-ventilated chemical fume hood.<sup>[5][6]</sup> For large quantities, consider a glove box or other contained system.

- Personal Protective Equipment (PPE): Wear a lab coat, splash goggles or a face shield, and double nitrile gloves (>5 MIL).[7] For reactions with organic solvents, select gloves with appropriate chemical resistance.[7]
- Incompatible Materials: Keep TBACN strictly separated from acids and strong oxidizing agents.[5] Contact with acids will liberate highly toxic and flammable hydrogen cyanide (HCN) gas.[5][6]
- Spill & Emergency Procedures: Have a cyanide spill kit and emergency procedures in place. All personnel must be trained on the specific hazards and the immediate first aid response for cyanide exposure, which may include administering oxygen or specific antidotes like amyl nitrite.[5]

Q3: How does the solubility of TBACN affect scale-up?

TBACN's solubility is crucial for reaction success but can complicate purification. While it is soluble in many aprotic polar solvents, its solubility in less polar solvents is limited, and it is only slightly soluble in water.[1][8] At larger scales, incomplete dissolution can lead to non-reproducible reaction kinetics and lower yields. Conversely, its high solubility in the reaction solvent can make its removal during work-up challenging.[9]

Q4: What are the best methods for removing residual tetrabutylammonium salts during work-up?

Removing the tetrabutylammonium cation post-reaction is a common challenge. Standard aqueous extractions can be ineffective if the product is also polar, or can lead to emulsions.[9]

- Aqueous Extraction: For non-polar products, repeated washing with brine can help partition the salt into the aqueous layer.[9]
- Ion-Exchange Chromatography: Using a cation exchange resin (e.g., Dowex® 50WX8) is a highly effective method.[9][10][11] The resin captures the tetrabutylammonium cation, which can then be filtered off.[10]
- Precipitation/Crystallization: If the product is crystalline, crystallization can leave the highly soluble TBACN and related salts in the mother liquor.

## Troubleshooting Guide

Issue	Potential Cause(s)	Recommended Solution(s)
Low or Inconsistent Yield	<p>1. Incomplete Dissolution: TBACN may not be fully dissolved at the start of the reaction, especially in large volumes. 2. Moisture Contamination: TBACN is hygroscopic and can decompose in the presence of water, potentially forming HCN. [12] 3. Inefficient Mixing: Poor agitation in a large reactor can lead to localized concentration gradients and side reactions.</p>	<p>1. Choose a solvent with high solubility for TBACN (see table below). Consider gentle heating or starting with a more concentrated solution and then diluting. 2. Dry solvents and reagents thoroughly. Handle TBACN under an inert atmosphere (e.g., Nitrogen, Argon). 3. Use an appropriate overhead stirrer and ensure the vessel has baffles to improve mixing efficiency. Monitor the reaction at different locations in the reactor if possible.</p>
Formation of Side Products	<p>1. Excess Nucleophile: The cyanide concentration may be too high, leading to undesired secondary reactions. 2. Reaction Temperature: Exothermic reactions can experience temperature spikes ("runaways") at scale due to a lower surface-area-to-volume ratio, leading to decomposition or side reactions.[13]</p>	<p>1. Perform stoichiometric calculations carefully. Consider adding the TBACN solution slowly over time to control its concentration. 2. Use a reactor with efficient heat exchange (e.g., a jacketed reactor). Add reagents slowly and monitor the internal temperature continuously. Perform a reaction calorimetry study on a small scale first.</p>
Difficult Product Purification	<p>1. Emulsion during Work-up: The tetrabutylammonium salt can act as a surfactant or phase-transfer catalyst, stabilizing emulsions between aqueous and organic layers.[9] 2. Co-elution during</p>	<p>1. Add brine (saturated NaCl solution) to the aqueous layer to break the emulsion.[9] Alternatively, filter the entire mixture through a pad of Celite® or use centrifugation. 2. Use a cation exchange resin</p>

Chromatography: The salt may have similar polarity to the desired product, making separation by silica gel chromatography difficult. to remove the tetrabutylammonium cation before chromatography.[9][10] This is often the most robust solution.

Safety Concerns (e.g., HCN detection)

1. Acidic Conditions:  
Accidental introduction of an acid (even atmospheric CO<sub>2</sub> in the presence of moisture) can generate HCN gas.[5]

1. Ensure all reagents and solvents are neutral or basic. Work in a well-ventilated fume hood with an HCN detector present. Maintain a slightly basic pH if compatible with the reaction chemistry.

## Data Presentation

Table 1: Solubility of **Tetrabutylammonium Cyanide** in Common Solvents

Solvent	Solubility (g / 100 mL)	Reference
Methylene Chloride	~80	
Acetonitrile	~70	
Acetone	~60	
Dimethylformamide (DMF)	~50	
Tetrahydrofuran (THF)	~40	
Benzene	~25	
Water	Slightly Soluble / Decomposes	[1][12]
Methanol	Slightly Soluble	[8]

Table 2: Physical Properties of **Tetrabutylammonium Cyanide**

Property	Value	Reference
Molecular Formula	C <sub>17</sub> H <sub>36</sub> N <sub>2</sub>	[1]
Molar Mass	268.48 g/mol	[14]
Appearance	White to off-white solid/powder	[1][5]
Melting Point	89-92 °C	[15]
Purity (Typical)	≥95%	[1]

## Experimental Protocols

### Protocol: Scale-Up of a Nucleophilic Substitution Reaction (General)

This protocol outlines a general procedure for a nucleophilic substitution of an alkyl halide with TBACN, scaling from a 10 mmol lab scale to a 200 mmol pilot scale.

Materials:

- Alkyl Halide (R-X)
- **Tetrabutylammonium Cyanide (TBACN)**, handled under inert gas
- Anhydrous Acetonitrile (MeCN)
- Dowex® 50WX8 Cation Exchange Resin
- Diatomaceous Earth (Celite®)
- Ethyl Acetate (EtOAc)
- Deionized Water & Brine

Procedure:

- Reactor Setup (200 mmol scale):

- Set up a 1 L jacketed glass reactor equipped with an overhead mechanical stirrer, temperature probe, condenser, and nitrogen inlet.
- Ensure the system is completely dry by purging with nitrogen while gently heating.
- Reagent Charging:
  - Charge the reactor with the Alkyl Halide (200 mmol).
  - Add anhydrous acetonitrile (400 mL) via cannula transfer.
  - Begin stirring to ensure a homogeneous solution.
  - In a separate dry flask under nitrogen, dissolve TBACN (59.1 g, 220 mmol, 1.1 eq) in anhydrous acetonitrile (100 mL). Note: A slight excess of TBACN is used to ensure full conversion.
- Reaction Execution:
  - Slowly add the TBACN solution to the reactor via an addition funnel or syringe pump over 30 minutes.
  - Monitor the internal temperature. If a significant exotherm is observed, slow the addition rate and/or cool the reactor jacket.
  - Heat the reaction mixture to the desired temperature (e.g., 60 °C) and maintain for 4-12 hours.
  - Monitor reaction progress by taking aliquots and analyzing via TLC, GC, or LCMS until the starting material is consumed.
- Work-up and Catalyst Removal:
  - Cool the reactor to room temperature.
  - In a separate vessel, swell Dowex® 50WX8 resin (120 g, ~3 eq) in methanol, then filter and wash with fresh acetonitrile.

- Add the pre-swelled resin to the reaction mixture and stir vigorously for 2 hours.[9][10]
- Set up a filter funnel with a pad of Celite® and filter the reaction mixture, washing the resin cake thoroughly with acetonitrile.
- Combine the filtrates and concentrate under reduced pressure using a rotary evaporator.
- Purification:
  - Dissolve the crude residue in Ethyl Acetate (500 mL).
  - Transfer to a separatory funnel and wash with water (2 x 250 mL) and then brine (1 x 250 mL) to remove any remaining water-soluble impurities.
  - Dry the organic layer over anhydrous sodium sulfate, filter, and concentrate in vacuo to yield the crude nitrile product (R-CN).
  - If necessary, perform final purification by flash column chromatography or crystallization.

## Mandatory Visualizations



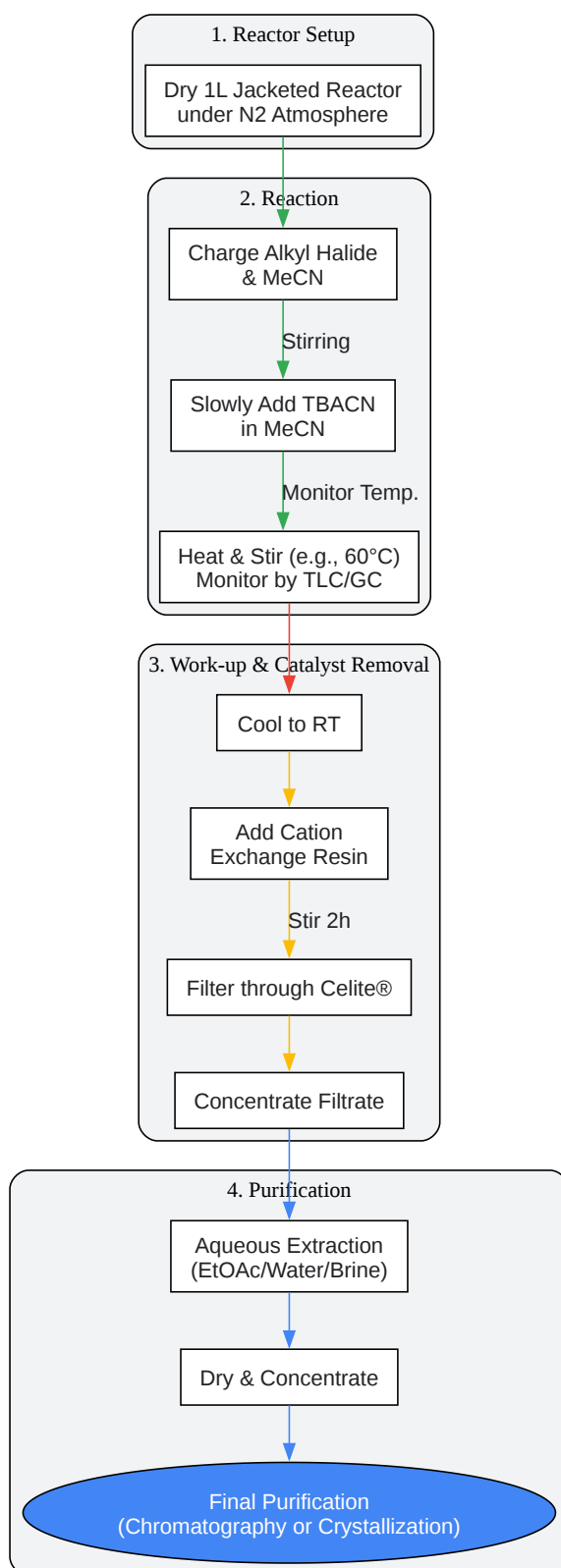

[Click to download full resolution via product page](#)

Caption: General workflow for a scaled-up reaction using TBACN.

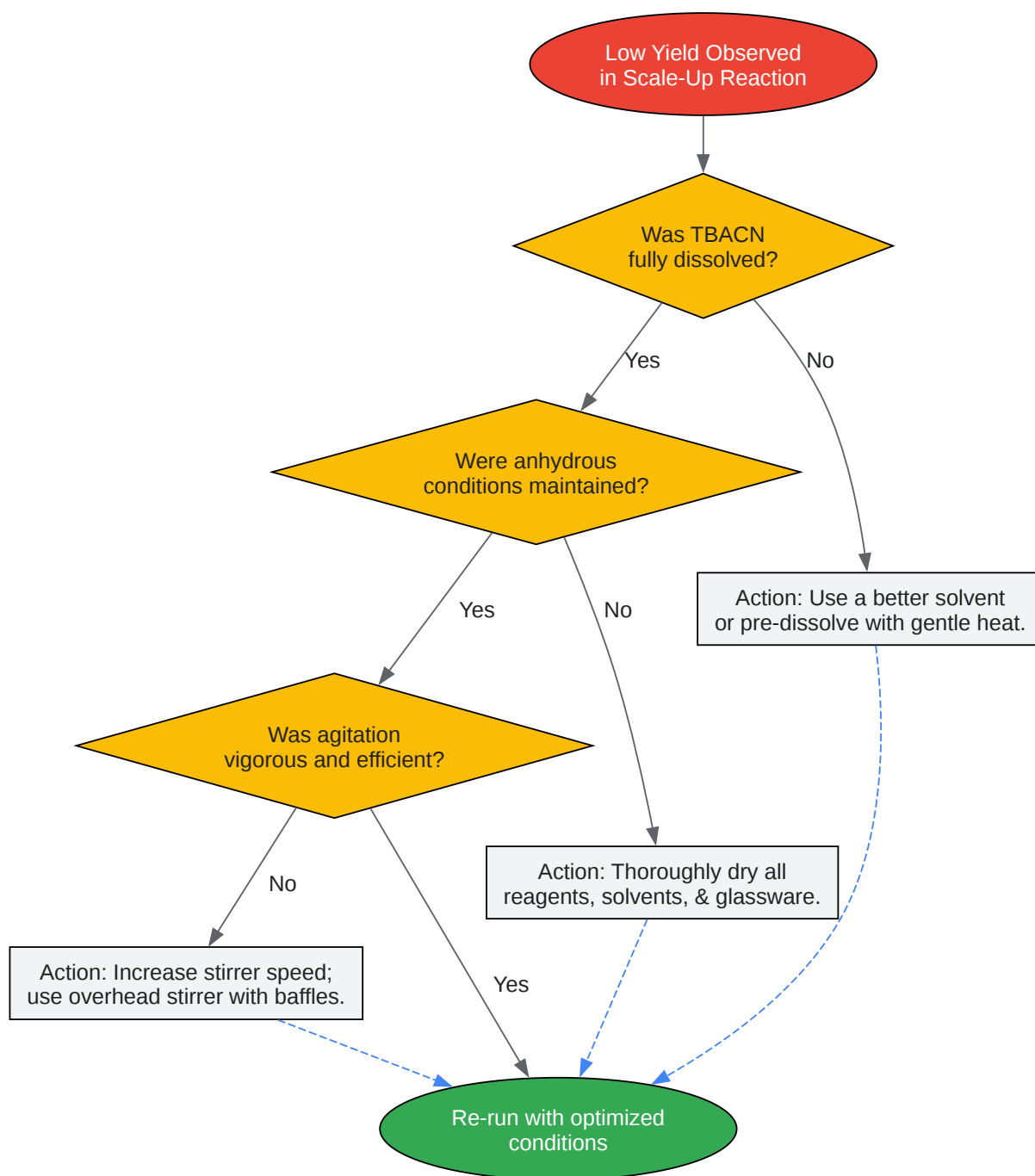

[Click to download full resolution via product page](#)

Caption: Troubleshooting logic for low yield in TBACN reactions.

**Need Custom Synthesis?**

BenchChem offers custom synthesis for rare earth carbides and specific isotopic labeling.

Email: [info@benchchem.com](mailto:info@benchchem.com) or [Request Quote Online](#).

## References

- 1. CAS 10442-39-4: tetrabutylammonium cyanide | CymitQuimica [[cymitquimica.com](http://cymitquimica.com)]
- 2. [researchgate.net](http://researchgate.net) [[researchgate.net](http://researchgate.net)]
- 3. [researchgate.net](http://researchgate.net) [[researchgate.net](http://researchgate.net)]
- 4. [phasetransfercatalysis.com](http://phasetransfercatalysis.com) [[phasetransfercatalysis.com](http://phasetransfercatalysis.com)]
- 5. [datasheets.scbt.com](http://datasheets.scbt.com) [[datasheets.scbt.com](http://datasheets.scbt.com)]
- 6. [ehs.unm.edu](http://ehs.unm.edu) [[ehs.unm.edu](http://ehs.unm.edu)]
- 7. [bu.edu](http://bu.edu) [[bu.edu](http://bu.edu)]
- 8. Tetrabutylammonium cyanide 95 10442-39-4 [[sigmaaldrich.com](http://sigmaaldrich.com)]
- 9. [benchchem.com](http://benchchem.com) [[benchchem.com](http://benchchem.com)]
- 10. [orgsyn.org](http://orgsyn.org) [[orgsyn.org](http://orgsyn.org)]
- 11. CN113651865A - Method for removing tetrabutylammonium fluoride - Google Patents [[patents.google.com](http://patents.google.com)]
- 12. [chemicalbook.com](http://chemicalbook.com) [[chemicalbook.com](http://chemicalbook.com)]
- 13. [benchchem.com](http://benchchem.com) [[benchchem.com](http://benchchem.com)]
- 14. [chembk.com](http://chembk.com) [[chembk.com](http://chembk.com)]
- 15. 四丁基氰化铵 95% | Sigma-Aldrich [[sigmaaldrich.com](http://sigmaaldrich.com)]
- To cite this document: BenchChem. [Technical Support Center: Scaling Up Reactions with Tetrabutylammonium Cyanide]. BenchChem, [2025]. [Online PDF]. Available at: [<https://www.benchchem.com/product/b079372#scaling-up-reactions-involving-tetrabutylammonium-cyanide>]

---

**Disclaimer & Data Validity:**

The information provided in this document is for Research Use Only (RUO) and is strictly not intended for diagnostic or therapeutic procedures. While BenchChem strives to provide accurate protocols, we make no warranties, express or implied, regarding the fitness of this product for every specific experimental setup.

**Technical Support:** The protocols provided are for reference purposes. Unsure if this reagent suits your experiment? [[Contact our Ph.D. Support Team for a compatibility check](#)]

**Need Industrial/Bulk Grade?** [Request Custom Synthesis Quote](#)

## BenchChem

Our mission is to be the trusted global source of essential and advanced chemicals, empowering scientists and researchers to drive progress in science and industry.

### Contact

Address: 3281 E Guasti Rd  
Ontario, CA 91761, United States  
Phone: (601) 213-4426  
Email: [info@benchchem.com](mailto:info@benchchem.com)