

# Technical Support Center: Saucerneol Stability and Degradation in Solution

**Author:** BenchChem Technical Support Team. **Date:** December 2025

## Compound of Interest

Compound Name: Saucerneol

Cat. No.: B12426789

[Get Quote](#)

This technical support center provides guidance for researchers, scientists, and drug development professionals on the stability and degradation of **Saucerneol** in solution. The information is presented in a question-and-answer format to address common issues encountered during experimental work.

## Frequently Asked Questions (FAQs)

Q1: What are the primary factors that can influence the stability of **Saucerneol** in solution?

The stability of **Saucerneol**, a lignan isolated from *Saururus chinensis*, can be influenced by several factors. While specific data for **Saucerneol** is limited, general principles of chemical stability suggest that the following should be considered:

- **pH:** The acidity or alkalinity of the solution can catalyze hydrolytic degradation, particularly if ester or ether linkages are present in the molecule's structure.
- **Temperature:** Elevated temperatures can accelerate the rate of chemical degradation.
- **Light:** Exposure to ultraviolet (UV) or visible light can lead to photolytic degradation. It is advisable to handle and store **Saucerneol** solutions in light-protected containers.
- **Oxygen:** The presence of oxygen can lead to oxidative degradation. Using de-gassed solvents and storing solutions under an inert atmosphere (e.g., nitrogen or argon) can mitigate this.

- **Solvent Type:** The choice of solvent can impact stability. Protic solvents may participate in degradation reactions. It is crucial to use high-purity solvents and assess their compatibility with **Saucerneol**.

Q2: How can I monitor the degradation of **Saucerneol** in my experiments?

Monitoring the degradation of **Saucerneol** typically involves analytical techniques that can separate the parent compound from its potential degradation products. High-Performance Liquid Chromatography (HPLC) is one of the most common methods used for stability testing due to its high sensitivity and resolving power.[1] Other techniques include Liquid Chromatography-Mass Spectrometry (LC-MS) for identifying unknown degradation products.[2]

Q3: What are the expected degradation products of **Saucerneol**?

Currently, there is limited published information detailing the specific degradation products of **Saucerneol**. To identify potential degradation products, it is recommended to perform forced degradation studies.[3][4] These studies involve subjecting a **Saucerneol** solution to harsh conditions (e.g., strong acid, strong base, high temperature, UV light, and oxidizing agents) to intentionally induce degradation.[3][4] The resulting mixture can then be analyzed, typically by LC-MS, to identify and characterize the degradation products.

Q4: Are there any known signaling pathways affected by **Saucerneol** that I should be aware of during my experiments?

Yes, studies on **Saucerneol F** and **Saucerneol G** have elucidated their effects on specific cellular signaling pathways. This is crucial for researchers in drug development as degradation of the compound could alter its biological activity.

- **Saucerneol F** has been shown to inhibit degranulation and eicosanoid generation in mast cells by suppressing the phosphorylation of Mitogen-Activated Protein Kinases (MAPKs), including ERK1/2, JNK, and p38.[5] It also reduces intracellular Ca<sup>2+</sup> influx by inhibiting PLC $\gamma$ 1 phosphorylation.[5]
- **Saucerneol G** has been found to inhibit the induction of matrix metalloproteinase-9 (MMP-9) in lipopolysaccharide-stimulated cells by blocking the activation of Nuclear Factor- $\kappa$ B (NF- $\kappa$ B) and MAPKs.[6]

## Troubleshooting Guides

Issue 1: I am observing a rapid loss of **Saucerneol** in my solution, even under standard storage conditions.

- Possible Cause 1: Inappropriate Solvent: The solvent may be reacting with **Saucerneol**.
  - Troubleshooting Step: Prepare fresh solutions in different high-purity solvents (e.g., ethanol, DMSO, acetonitrile) to assess solvent compatibility. Ensure the solvents are anhydrous and free of peroxides.
- Possible Cause 2: Presence of Contaminants: Contaminants in the solvent or on the glassware may be catalyzing degradation.
  - Troubleshooting Step: Use fresh, high-purity solvents and thoroughly clean all glassware. Consider using amber-colored glassware to protect from light.
- Possible Cause 3: Exposure to Light: **Saucerneol** may be photolabile.
  - Troubleshooting Step: Prepare and store the solution in the dark or in amber vials. Wrap containers in aluminum foil for extra protection.
- Possible Cause 4: Oxidative Degradation: Dissolved oxygen in the solvent could be degrading the compound.
  - Troubleshooting Step: Use solvents that have been de-gassed by sparging with an inert gas like nitrogen or argon. Store the solution under an inert atmosphere.

Issue 2: I am seeing multiple unexpected peaks in my chromatogram when analyzing a **Saucerneol** sample.

- Possible Cause 1: Degradation During Sample Preparation or Analysis: The analytical method itself might be causing degradation.
  - Troubleshooting Step: Evaluate the stability of **Saucerneol** in the mobile phase. Prepare a sample and inject it at different time points (e.g., 0, 2, 4, 8 hours) to see if new peaks appear or if the main peak decreases over time.

- Possible Cause 2: Contaminated Sample or Solvent: The unexpected peaks could be impurities.
  - Troubleshooting Step: Analyze a blank (solvent only) to rule out solvent contamination. Ensure the purity of your **Saucerneol** standard.
- Possible Cause 3: Formation of Degradation Products: The additional peaks are likely degradation products.
  - Troubleshooting Step: If the appearance of these peaks correlates with a decrease in the **Saucerneol** peak over time or under stress conditions, they are likely degradation products. Further characterization using techniques like LC-MS would be necessary for identification.

## Data Presentation

When presenting quantitative stability data for **Saucerneol**, it is essential to use a clear and structured format. The following tables are templates for how such data can be organized.

Table 1: Example of pH Stability Data for **Saucerneol**

pH	Temperature (°C)	Initial Concentration (µg/mL)	Concentration after 24h (µg/mL)	% Degradation
2.0	25	100.0	95.2	4.8
4.0	25	100.0	98.1	1.9
7.0	25	100.0	99.5	0.5
9.0	25	100.0	92.3	7.7
12.0	25	100.0	85.6	14.4

Table 2: Example of Thermal and Photostability Data for **Saucerneol**

Condition	Duration	Initial Concentration (µg/mL)	Final Concentration (µg/mL)	% Degradation
40°C	48h	100.0	97.8	2.2
60°C	48h	100.0	91.5	8.5
80°C	48h	100.0	78.9	21.1
UV Light (254 nm)	24h	100.0	88.4	11.6
Visible Light	24h	100.0	99.1	0.9

## Experimental Protocols

The following are detailed methodologies for key experiments to assess the stability of **Saucerneol**.

### Protocol 1: Forced Degradation Study - Hydrolytic Degradation

- Preparation of Stock Solution: Prepare a stock solution of **Saucerneol** in a suitable organic solvent (e.g., methanol or acetonitrile) at a concentration of 1 mg/mL.
- Acidic Hydrolysis:
  - Add 1 mL of the stock solution to a vial containing 9 mL of 0.1 M HCl.
  - Incubate the solution at a controlled temperature (e.g., 60°C) for a specified time (e.g., 24 hours).
  - At designated time points, withdraw an aliquot, neutralize it with an equivalent amount of 0.1 M NaOH, and dilute with mobile phase to the target concentration for analysis.
- Alkaline Hydrolysis:
  - Add 1 mL of the stock solution to a vial containing 9 mL of 0.1 M NaOH.

- Incubate and sample as described for acidic hydrolysis, neutralizing with 0.1 M HCl.
- Neutral Hydrolysis:
  - Add 1 mL of the stock solution to a vial containing 9 mL of purified water.
  - Incubate and sample as described above.
- Analysis: Analyze all samples by a stability-indicating HPLC method to determine the percentage of **Saucerneol** remaining and to observe the formation of degradation products.

#### Protocol 2: Forced Degradation Study - Oxidative Degradation

- Preparation of Stock Solution: Prepare a 1 mg/mL stock solution of **Saucerneol**.
- Oxidative Stress:
  - Add 1 mL of the stock solution to a vial containing 9 mL of 3% hydrogen peroxide.
  - Keep the solution at room temperature and protect it from light.
  - Monitor the reaction for a specified period (e.g., up to 24 hours).
- Sampling and Analysis: At various time points, withdraw an aliquot, dilute with mobile phase, and immediately analyze by HPLC.

#### Protocol 3: Forced Degradation Study - Photolytic Degradation

- Sample Preparation: Prepare a solution of **Saucerneol** in a suitable solvent (e.g., methanol:water 1:1) at a known concentration.
- Light Exposure:
  - Expose the solution in a photostability chamber to a light source with a specific wavelength (e.g., UV at 254 nm or a combination of UV and visible light).
  - Simultaneously, keep a control sample in the dark at the same temperature.

- Analysis: After a defined period of exposure, analyze both the exposed and control samples by HPLC to quantify the extent of photodegradation.

## Visualizations

The following diagrams illustrate the known signaling pathways affected by **Saucerneol** derivatives.

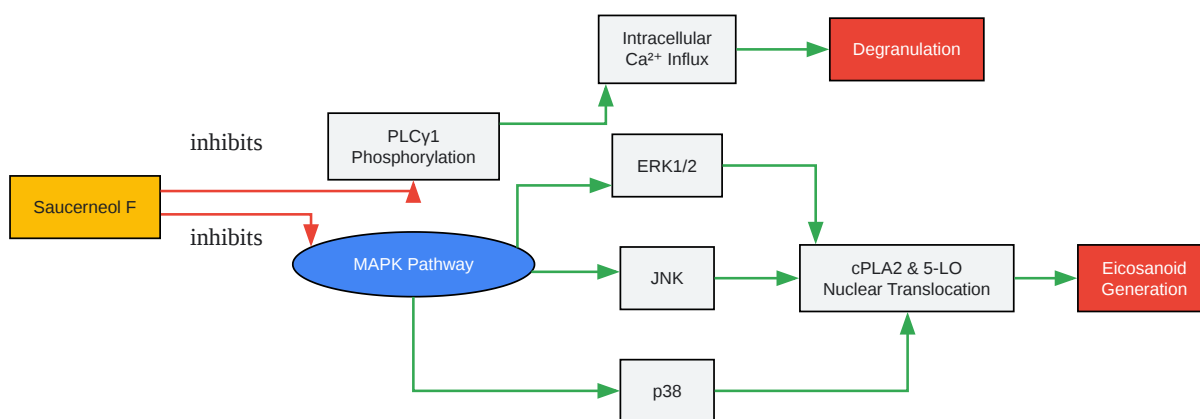

[Click to download full resolution via product page](#)

Caption: Signaling pathway of **Saucerneol** F in mast cells.

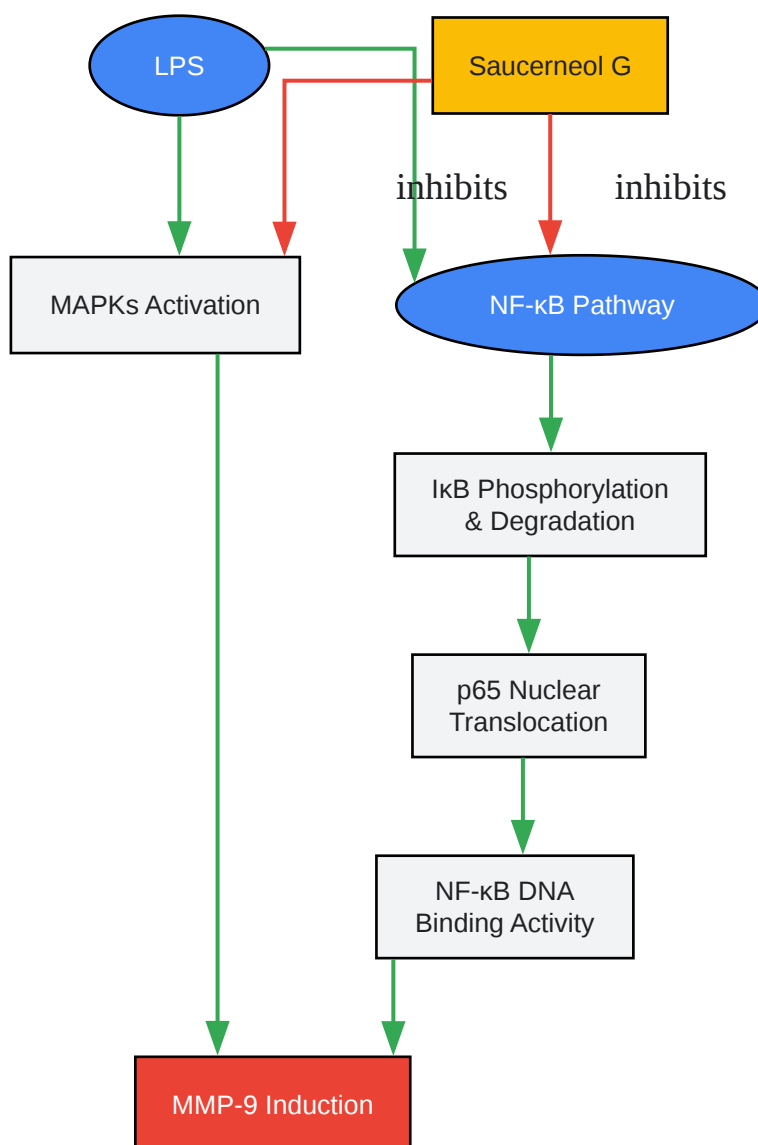

[Click to download full resolution via product page](#)

Caption: Inhibition of MMP-9 induction by **Saucerneol G**.

### Need Custom Synthesis?

BenchChem offers custom synthesis for rare earth carbides and specific isotopic labeling.

Email: [info@benchchem.com](mailto:info@benchchem.com) or [Request Quote Online](#).

## References



- 1. Analytical Techniques In Stability Testing | Separation Science [sepscience.com]
- 2. chromatographyonline.com [chromatographyonline.com]
- 3. researchgate.net [researchgate.net]
- 4. journals.ekb.eg [journals.ekb.eg]
- 5. Saucerneol F, a New Lignan Isolated from Saururus chinensis, Attenuates Degranulation via Phospholipase Cy 1 Inhibition and Eicosanoid Generation by Suppressing MAP Kinases in Mast Cells - PubMed [pubmed.ncbi.nlm.nih.gov]
- 6. Saucerneol G, a new lignan, from Saururus chinensis inhibits matrix metalloproteinase-9 induction via a nuclear factor κB and mitogen activated protein kinases in lipopolysaccharide-stimulated RAW264.7 cells - PubMed [pubmed.ncbi.nlm.nih.gov]
- To cite this document: BenchChem. [Technical Support Center: Saucerneol Stability and Degradation in Solution]. BenchChem, [2025]. [Online PDF]. Available at: [https://www.benchchem.com/product/b12426789#saucerneol-stability-and-degradation-in-solution]

---

#### Disclaimer & Data Validity:

The information provided in this document is for Research Use Only (RUO) and is strictly not intended for diagnostic or therapeutic procedures. While BenchChem strives to provide accurate protocols, we make no warranties, express or implied, regarding the fitness of this product for every specific experimental setup.

**Technical Support:** The protocols provided are for reference purposes. Unsure if this reagent suits your experiment? [[Contact our Ph.D. Support Team for a compatibility check](#)]

**Need Industrial/Bulk Grade?** [Request Custom Synthesis Quote](#)

## BenchChem

Our mission is to be the trusted global source of essential and advanced chemicals, empowering scientists and researchers to drive progress in science and industry.

#### Contact

Address: 3281 E Guasti Rd

Ontario, CA 91761, United States

Phone: (601) 213-4426

Email: [info@benchchem.com](mailto:info@benchchem.com)