

Technical Support Center: Overcoming Saredutant Delivery Challenges for CNS Targets

Author: BenchChem Technical Support Team. **Date:** December 2025

Compound of Interest

Compound Name: Saredutant

Cat. No.: B1681467

[Get Quote](#)

This technical support center provides researchers, scientists, and drug development professionals with essential guidance for navigating the complexities of delivering **saredutant** to Central Nervous System (CNS) targets. The information is presented in a question-and-answer format to directly address potential issues encountered during experimentation.

Frequently Asked Questions (FAQs)

Q1: What are the predicted challenges in delivering **saredutant** across the Blood-Brain Barrier (BBB)?

A1: Based on its physicochemical properties, **saredutant** presents a mixed profile for CNS penetration. While its topological polar surface area (TPSA) is favorable, its high molecular weight and predicted high lipophilicity may pose challenges.

- **High Molecular Weight:** **Saredutant** has a molecular weight of 552.53 g/mol, which is above the generally accepted optimal range of <450 g/mol for CNS drugs[1]. This larger size can hinder passive diffusion across the tight junctions of the BBB.
- **High Lipophilicity:** The predicted XLogP for **saredutant** is 6.27[2]. While a moderate degree of lipophilicity is required to cross the BBB, very high values can lead to increased binding to plasma proteins and non-specific binding within the brain tissue, potentially reducing the unbound concentration available to engage the target.

- Potential for P-glycoprotein (P-gp) Efflux: Although not definitively confirmed in publicly available literature, molecules with high lipophilicity can be substrates for efflux transporters like P-glycoprotein (P-gp) at the BBB. If **saredutant** is a P-gp substrate, it would be actively transported out of the brain, significantly limiting its CNS exposure.

Q2: Is **saredutant** likely to be a substrate for P-glycoprotein (P-gp)?

A2: There is no direct experimental evidence in the public domain confirming that **saredutant** is a P-gp substrate. However, its high lipophilicity is a characteristic shared by many known P-gp substrates[3]. Therefore, it is crucial to experimentally determine the P-gp efflux ratio for **saredutant** to accurately assess its potential for CNS penetration.

Q3: What formulation strategies could potentially improve the CNS delivery of **saredutant**?

A3: Several formulation strategies could be explored to enhance the brain uptake of **saredutant**:

- Nanoparticle-based Delivery Systems: Encapsulating **saredutant** in nanoparticles, such as liposomes or polymeric nanoparticles, could protect it from metabolic degradation and potentially facilitate its transport across the BBB[4].
- Prodrug Approach: Modifying the **saredutant** molecule to create a more lipophilic or actively transported prodrug that is converted to the active form in the brain is a viable strategy[4].
- Intranasal Delivery: Bypassing the BBB altogether through intranasal administration is a promising alternative route for direct-to-brain delivery.

Troubleshooting Guides

In Vitro Blood-Brain Barrier (BBB) Model: Low Transendothelial Electrical Resistance (TEER)

Problem: You are establishing an in vitro BBB model (e.g., Caco-2 or co-culture with brain endothelial cells and astrocytes) to test **saredutant** permeability, but the TEER values are consistently low, indicating a leaky monolayer.

| Potential Cause | Troubleshooting Step |
|-------------------------|---|
| Cell Culture Conditions | Ensure optimal cell seeding density and allow sufficient time for differentiation (typically 21 days for Caco-2 cells). Use high-quality, pre-coated Transwell inserts. |
| Media Composition | Supplementing the media with hydrocortisone can enhance tight junction formation. Ensure the media is fresh and at the correct pH. |
| Cell Line Integrity | Use a low passage number for the cell line, as high passage numbers can lead to a loss of differentiation capacity. |
| Measurement Technique | Ensure the "chopstick" electrodes are properly positioned and not touching the cell monolayer. Allow the plate to equilibrate to room temperature before measurement. |

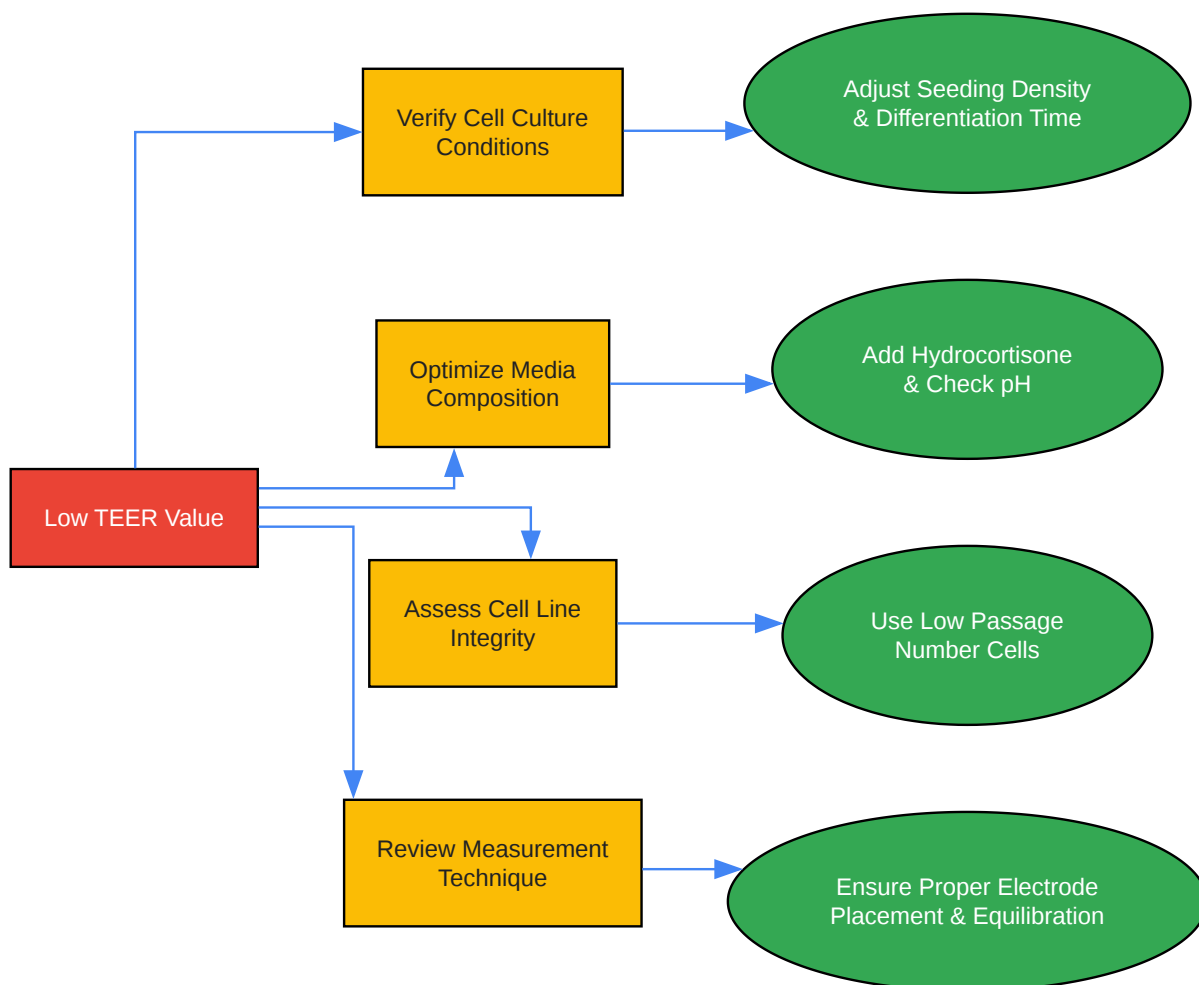

[Click to download full resolution via product page](#)

Caption: Troubleshooting workflow for low TEER values.

In Vitro Permeability Assay: High Variability

Problem: You are performing a Caco-2 permeability assay with **saredutant**, and the results show high variability between wells and experiments.

| Potential Cause | Troubleshooting Step |
|----------------------|--|
| Compound Solubility | Saredutant's high lipophilicity may lead to poor aqueous solubility. Ensure it is fully dissolved in the transport buffer. A small percentage of a co-solvent like DMSO can be used, but the final concentration should be low (<1%) to avoid cell toxicity. |
| Non-specific Binding | The compound may be binding to the plastic of the assay plate. Include a protein like Bovine Serum Albumin (BSA) in the receiver buffer to reduce non-specific binding. |
| Pipetting Errors | Calibrate pipettes regularly. Use reverse pipetting for potentially viscous solutions. |
| Edge Effects | Avoid using the outermost wells of the multi-well plate, as they are more prone to evaporation and temperature fluctuations. |

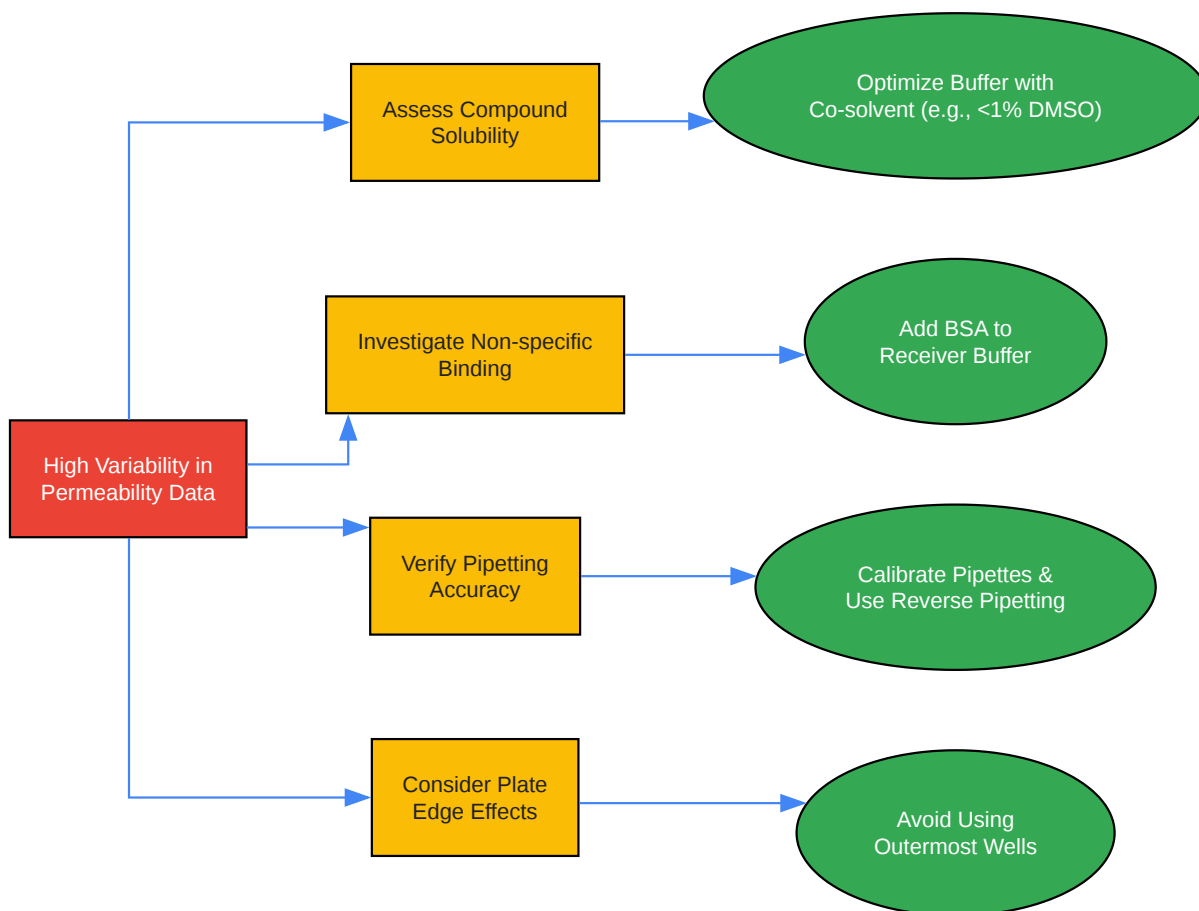

[Click to download full resolution via product page](#)

Caption: Troubleshooting workflow for high permeability variability.

Data Presentation

Physicochemical Properties of Saredutant

| Property | Value | Implication for CNS Delivery |
|---------------------------------------|---------------------|--|
| Molecular Weight | 552.53 g/mol | Potentially unfavorable (ideal <450 g/mol) |
| Topological Polar Surface Area (TPSA) | 52.7 Å ² | Favorable (ideal <90 Å ²) |
| XLogP (Predicted) | 6.27 | Potentially unfavorable (high lipophilicity) |
| Hydrogen Bond Donors | 1 | Favorable (ideal ≤3) |
| Hydrogen Bond Acceptors | 5 | Borderline (ideal <7) |

Experimental CNS Delivery Parameters for Saredutant (To be Determined)

| Parameter | Experimental Value | Method |
|---|--------------------|---|
| Apparent Permeability (P _{app}) in Caco-2 (A-B) | Not available | Caco-2 Permeability Assay |
| Apparent Permeability (P _{app}) in Caco-2 (B-A) | Not available | Caco-2 Permeability Assay |
| Efflux Ratio (B-A / A-B) | Not available | Caco-2 Permeability Assay |
| Brain-to-Plasma Ratio (K _p) | Not available | In vivo Biodistribution Study |
| Unbound Brain-to-Plasma Ratio (K _{p,uu}) | Not available | In vivo Biodistribution with Brain Slice Method |

Experimental Protocols

Protocol 1: Caco-2 Permeability Assay for Saredutant

- Cell Culture:
 - Seed Caco-2 cells onto Transwell inserts at a density of 6×10^4 cells/cm².

- Culture for 21-25 days to allow for differentiation and monolayer formation.
- Monitor monolayer integrity by measuring Transendothelial Electrical Resistance (TEER) weekly. Proceed with the assay when TEER values are stable and $>200 \Omega \cdot \text{cm}^2$.
- Permeability Assay:
 - Wash the Caco-2 monolayers with pre-warmed transport buffer (e.g., Hank's Balanced Salt Solution with 25 mM HEPES, pH 7.4).
 - Prepare the dosing solution of **saredutant** in transport buffer. A final DMSO concentration of $<1\%$ is recommended if required for solubility.
 - For apical-to-basolateral (A-B) permeability, add the **saredutant** dosing solution to the apical chamber and fresh transport buffer to the basolateral chamber.
 - For basolateral-to-apical (B-A) permeability, add the **saredutant** dosing solution to the basolateral chamber and fresh transport buffer to the apical chamber.
 - Incubate at 37°C with gentle shaking for 2 hours.
 - At the end of the incubation, collect samples from both the donor and receiver chambers.
- Sample Analysis:
 - Quantify the concentration of **saredutant** in the samples using a validated LC-MS/MS method.
 - Calculate the apparent permeability coefficient (P_{app}) using the following formula: $P_{\text{app}} = (dQ/dt) / (A * C_0)$ Where dQ/dt is the rate of permeation, A is the surface area of the membrane, and C_0 is the initial concentration in the donor chamber.

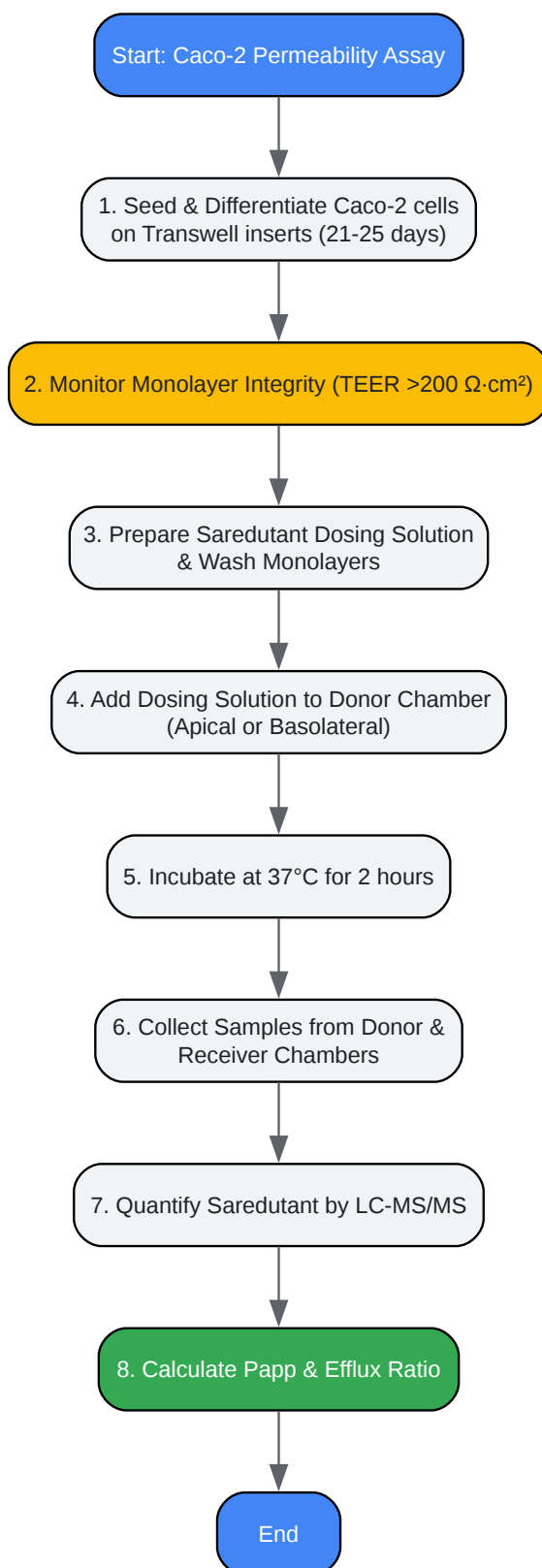

[Click to download full resolution via product page](#)

Caption: Experimental workflow for the Caco-2 permeability assay.

Protocol 2: In Vivo Brain Penetration Study

- Animal Dosing:
 - Administer **saredutant** to a cohort of rodents (e.g., mice or rats) via the intended clinical route (e.g., oral gavage or intravenous injection).
 - Use a formulation that ensures adequate bioavailability.
- Sample Collection:
 - At predetermined time points post-dosing (e.g., 0.5, 1, 2, 4, 6, and 24 hours), collect blood samples via cardiac puncture into heparinized tubes.
 - Immediately following blood collection, euthanize the animals and perfuse the vasculature with saline to remove residual blood from the brain.
 - Harvest the brains and store them at -80°C until analysis.
- Sample Processing:
 - Centrifuge the blood samples to separate the plasma.
 - Homogenize the brain tissue in a suitable buffer.
 - Perform protein precipitation on both plasma and brain homogenate samples.
- Quantitative Analysis:
 - Determine the concentration of **saredutant** in the plasma and brain homogenate samples using a validated LC-MS/MS method.
 - Calculate the brain-to-plasma concentration ratio (K_p) at each time point.

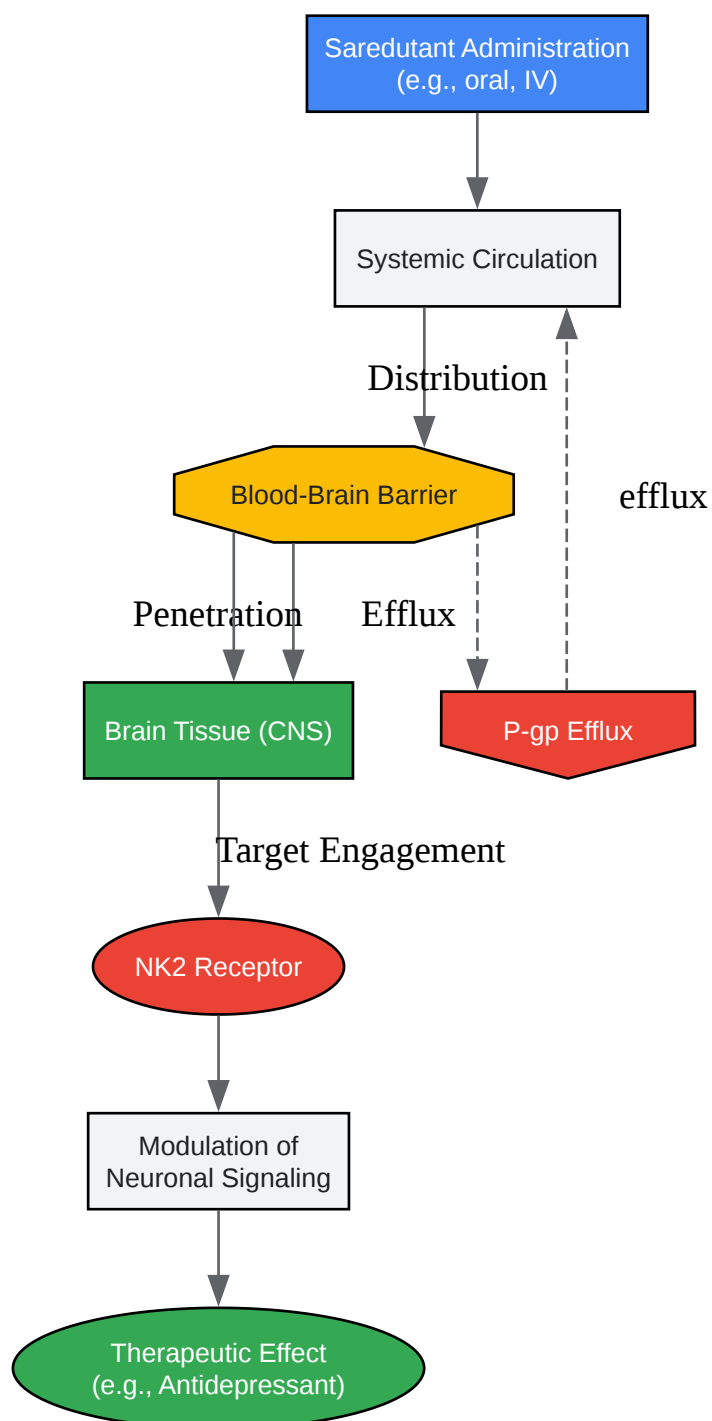

[Click to download full resolution via product page](#)

Caption: **Saredutant's** pathway to CNS target engagement.

Need Custom Synthesis?

BenchChem offers custom synthesis for rare earth carbides and specific isotopic labeling.

Email: info@benchchem.com or [Request Quote Online](#).

References

- 1. Validated LC-MS/MS method for simultaneous quantification of resveratrol levels in mouse plasma and brain and its application to pharmacokinetic and brain distribution studies - PubMed [pubmed.ncbi.nlm.nih.gov]
- 2. saredutant | Ligand page | IUPHAR/BPS Guide to PHARMACOLOGY [guidetopharmacology.org]
- 3. researchgate.net [researchgate.net]
- 4. Saredutant | C31H35Cl2N3O2 | CID 104974 - PubChem [pubchem.ncbi.nlm.nih.gov]
- To cite this document: BenchChem. [Technical Support Center: Overcoming Saredutant Delivery Challenges for CNS Targets]. BenchChem, [2025]. [Online PDF]. Available at: [https://www.benchchem.com/product/b1681467#overcoming-saredutant-delivery-challenges-for-cns-targets]

Disclaimer & Data Validity:

The information provided in this document is for Research Use Only (RUO) and is strictly not intended for diagnostic or therapeutic procedures. While BenchChem strives to provide accurate protocols, we make no warranties, express or implied, regarding the fitness of this product for every specific experimental setup.

Technical Support: The protocols provided are for reference purposes. Unsure if this reagent suits your experiment? [[Contact our Ph.D. Support Team for a compatibility check](#)]

Need Industrial/Bulk Grade? [Request Custom Synthesis Quote](#)

BenchChem

Our mission is to be the trusted global source of essential and advanced chemicals, empowering scientists and researchers to drive progress in science and industry.

Contact

Address: 3281 E Guasti Rd

Ontario, CA 91761, United States

Phone: (601) 213-4426

Email: info@benchchem.com