

Technical Support Center: Overcoming Resistance to Naproxen Sodium in Cell Lines

Author: BenchChem Technical Support Team. **Date:** December 2025

Compound of Interest

Compound Name: *Tixanox sodium*

Cat. No.: *B1262176*

[Get Quote](#)

This technical support center provides researchers, scientists, and drug development professionals with troubleshooting guides and frequently asked questions (FAQs) to address challenges encountered during in vitro experiments with naproxen sodium.

Frequently Asked Questions (FAQs)

Q1: My cell line is showing reduced sensitivity to naproxen sodium. How can I confirm resistance?

A1: Resistance to naproxen sodium is characterized by a significant increase in the half-maximal inhibitory concentration (IC₅₀). To confirm resistance, you should perform a dose-response assay, such as the MTT assay, to determine the IC₅₀ value in your cell line and compare it to a known sensitive cell line or previously established values for your cell line. A fold-increase of 2-5 or higher in the IC₅₀ value is generally considered indicative of resistance.

Q2: What are the common mechanisms of resistance to naproxen sodium in cancer cell lines?

A2: Resistance to naproxen sodium can arise from several mechanisms, broadly categorized as either target-related or non-target-related.

- **Target-Related Mechanisms:** While naproxen's primary targets are the cyclooxygenase (COX) enzymes, COX-1 and COX-2, resistance is often COX-independent.^[1]
- **Non-Target-Related Mechanisms:**

- Increased Drug Efflux: Overexpression of ATP-binding cassette (ABC) transporters, such as P-glycoprotein (ABCB1), can actively pump naproxen out of the cell, reducing its intracellular concentration and efficacy.[2]
- Activation of Alternative Signaling Pathways: Cancer cells can develop resistance by activating pro-survival signaling pathways that bypass the effects of naproxen. A key pathway implicated in naproxen resistance is the PI3K/Akt signaling pathway.[3][4]

Q3: How can I investigate the potential mechanisms of resistance in my cell line?

A3: To elucidate the resistance mechanisms in your cell line, you can perform a series of experiments:

- Assess Drug Efflux: Perform an efflux pump activity assay, such as the rhodamine 123 efflux assay, to determine if your cells are actively pumping out substrates of ABC transporters.
- Analyze Protein Expression: Use Western blotting to quantify the expression levels of key proteins involved in resistance, such as ABCB1 (P-glycoprotein), and components of the PI3K/Akt pathway (e.g., phosphorylated Akt).[3][5]
- Gene Expression Analysis: Conduct quantitative real-time PCR (qRT-PCR) or microarray analysis to identify changes in the expression of genes associated with drug resistance and survival pathways.

Q4: Are there strategies to overcome naproxen sodium resistance in my cell line?

A4: Yes, several strategies can be employed to overcome naproxen resistance in vitro:

- Combination Therapy:
 - With Efflux Pump Inhibitors: Co-administration of naproxen with an ABC transporter inhibitor, such as verapamil or cyclosporin A, can increase the intracellular concentration of naproxen and restore sensitivity.
 - With PI3K/Akt Pathway Inhibitors: Combining naproxen with a PI3K inhibitor (e.g., LY294002) or an Akt inhibitor can synergistically induce cell death in resistant cells.[6]

- With Other Chemotherapeutic Agents: Naproxen has been shown to have synergistic effects when combined with other anticancer drugs like sorafenib.[7]
- Use of Naproxen Derivatives: Novel derivatives of naproxen have been synthesized that may exhibit enhanced cytotoxic activity and bypass existing resistance mechanisms.[8]

Troubleshooting Guides

Problem 1: High variability in IC50 values from MTT assays.

Possible Cause	Troubleshooting Step
Uneven cell seeding	Ensure a homogenous single-cell suspension before seeding. Mix the cell suspension between pipetting into wells. Avoid "edge effects" by not using the outermost wells of the 96-well plate or by filling them with sterile PBS. [9]
Inconsistent incubation times	Adhere strictly to the same incubation times for drug treatment and MTT reagent addition across all experiments.
Incomplete formazan solubilization	Ensure complete dissolution of the formazan crystals by thorough mixing after adding the solubilization solution. Visually inspect wells under a microscope before reading the plate. [10]
Contamination	Regularly check cell cultures for any signs of bacterial or fungal contamination. Use sterile techniques and reagents.

Problem 2: No or weak signal in Western blot for target proteins (e.g., ABCB1, p-Akt).

Possible Cause	Troubleshooting Step
Low protein expression	Increase the amount of protein loaded onto the gel. Use a positive control cell line known to express the protein of interest.
Inefficient protein transfer	Optimize the transfer conditions (voltage, time, and buffer composition). Check the transfer efficiency by staining the membrane with Ponceau S after transfer.
Poor antibody quality	Use a validated antibody at the recommended dilution. Include a positive control to confirm antibody reactivity.
Protein degradation	Add protease and phosphatase inhibitors to your lysis buffer and keep samples on ice throughout the procedure.

Problem 3: Inconclusive results from the efflux pump activity assay.

Possible Cause	Troubleshooting Step
Suboptimal dye concentration	Titrate the concentration of the fluorescent substrate (e.g., rhodamine 123) to determine the optimal concentration that gives a strong signal without causing cytotoxicity. [11]
Incorrect incubation times	Optimize the loading and efflux times for your specific cell line.
Cell death	Ensure cell viability throughout the assay using a viability dye like propidium iodide.
Low expression of efflux pumps	Confirm the expression of the relevant ABC transporter (e.g., ABCB1) by Western blot or qRT-PCR.

Quantitative Data Summary

Table 1: IC50 Values of Naproxen Sodium in Various Cancer Cell Lines

Cell Line	Cancer Type	IC50 (μM)	Reference
MCF-7	Breast Cancer	>1000	[8]
MDA-MB-231	Breast Cancer	>1000	[8]
UM-UC-5	Bladder Cancer	~1000	[3]
UM-UC-14	Bladder Cancer	~1000	[3]
HCT-116	Colon Cancer	>1000	[2]
Caco-2	Colorectal Adenocarcinoma	>1000	[2]
HepG2	Hepatocellular Carcinoma	>1000	[2]
Hela	Epitheloid Cervix Carcinoma	>1000	[2]
A549	Lung Carcinoma	>1000	[2]
Hep2	Epidermoid Larynx Carcinoma	>1000	[2]
MCF-7 (Naproxen Derivative 4)	Breast Cancer	5.8	[8]
MDA-MB-231 (Naproxen Derivative 4)	Breast Cancer	6.2	[8]

Note: The high IC50 values for the parent compound, naproxen sodium, in many cancer cell lines suggest intrinsic resistance or the need for high concentrations to observe cytotoxic effects in vitro.

Experimental Protocols

Determination of IC50 using MTT Assay

This protocol is adapted from standard MTT assay procedures.[\[10\]](#)

Materials:

- Naproxen sodium
- Cell line of interest
- Complete culture medium
- 96-well plates
- MTT (3-(4,5-dimethylthiazol-2-yl)-2,5-diphenyltetrazolium bromide) solution (5 mg/mL in sterile PBS)
- Solubilization solution (e.g., DMSO or 0.01 M HCl in 10% SDS)
- Microplate reader

Procedure:

- Seed cells in a 96-well plate at a predetermined optimal density and allow them to adhere overnight.
- Prepare serial dilutions of naproxen sodium in complete culture medium.
- Remove the old medium from the wells and add 100 μ L of the various concentrations of naproxen sodium. Include untreated control wells (medium only).
- Incubate the plate for the desired treatment period (e.g., 24, 48, or 72 hours).
- After incubation, add 10 μ L of MTT solution to each well and incubate for 2-4 hours at 37°C, allowing the formation of formazan crystals.
- Carefully remove the medium and add 100 μ L of solubilization solution to each well.
- Mix thoroughly to dissolve the formazan crystals.

- Measure the absorbance at 570 nm using a microplate reader.
- Calculate the percentage of cell viability for each concentration relative to the untreated control.
- Plot the percentage of cell viability against the log of the naproxen sodium concentration and determine the IC₅₀ value using non-linear regression analysis.

Western Blot for ABCB1 and Phospho-Akt

This protocol is based on standard Western blotting procedures.[\[3\]](#)[\[5\]](#)

Materials:

- Cell lysates from treated and untreated cells
- RIPA buffer with protease and phosphatase inhibitors
- BCA protein assay kit
- SDS-PAGE gels
- Transfer buffer
- PVDF or nitrocellulose membrane
- Blocking buffer (e.g., 5% non-fat milk or BSA in TBST)
- Primary antibodies (anti-ABCB1, anti-phospho-Akt, anti-total-Akt, anti-GAPDH or β -actin)
- HRP-conjugated secondary antibodies
- ECL detection reagent
- Chemiluminescence imaging system

Procedure:

- Lyse cells in RIPA buffer and determine the protein concentration using a BCA assay.

- Denature equal amounts of protein from each sample by boiling in Laemmli buffer.
- Separate the proteins by SDS-PAGE.
- Transfer the separated proteins to a PVDF or nitrocellulose membrane.
- Block the membrane with blocking buffer for 1 hour at room temperature.
- Incubate the membrane with the primary antibody overnight at 4°C with gentle agitation.
- Wash the membrane three times with TBST.
- Incubate the membrane with the appropriate HRP-conjugated secondary antibody for 1 hour at room temperature.
- Wash the membrane three times with TBST.
- Apply ECL detection reagent and visualize the protein bands using a chemiluminescence imaging system.
- Quantify the band intensities using image analysis software and normalize to a loading control (e.g., GAPDH or β -actin).

Rhodamine 123 Efflux Assay

This protocol is adapted from standard efflux pump activity assays.[\[11\]](#)[\[12\]](#)

Materials:

- Cell line of interest
- Rhodamine 123
- Efflux buffer (e.g., HBSS with 1% FBS)
- Positive control inhibitor (e.g., verapamil)
- Flow cytometer or fluorescence plate reader

Procedure:

- Harvest cells and resuspend them in efflux buffer at a concentration of 1×10^6 cells/mL.
- Load the cells with rhodamine 123 (e.g., $1 \mu\text{g/mL}$) for a predetermined time (e.g., 30-60 minutes) at 37°C in the dark.
- Wash the cells twice with ice-cold efflux buffer to remove excess dye.
- Resuspend the cells in pre-warmed efflux buffer with or without the efflux pump inhibitor.
- Incubate the cells at 37°C to allow for efflux.
- At different time points (e.g., 0, 30, 60, 90 minutes), take aliquots of the cell suspension.
- Measure the intracellular fluorescence of rhodamine 123 using a flow cytometer or a fluorescence plate reader.
- A decrease in fluorescence over time indicates active efflux. Reduced efflux in the presence of an inhibitor confirms the involvement of efflux pumps.

Visualizations

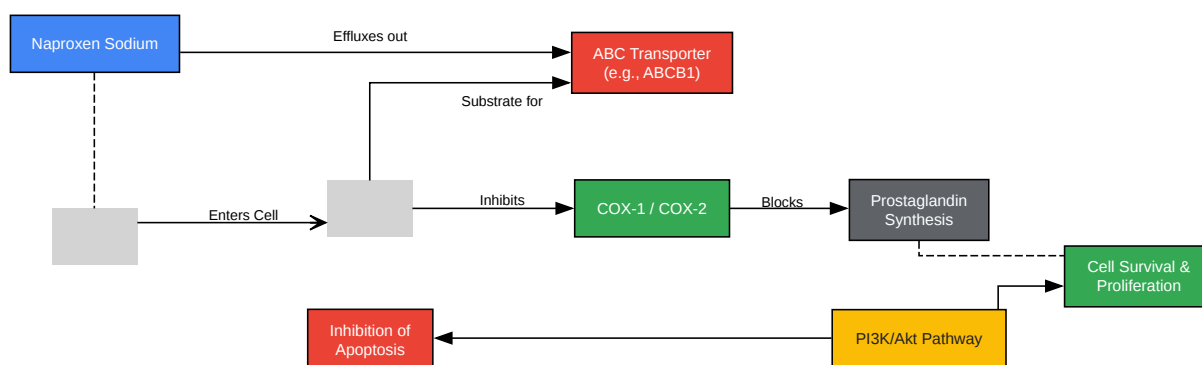

[Click to download full resolution via product page](#)

Caption: Mechanisms of naproxen action and resistance in a cancer cell.



[Click to download full resolution via product page](#)

Caption: Workflow for troubleshooting naproxen sodium resistance.

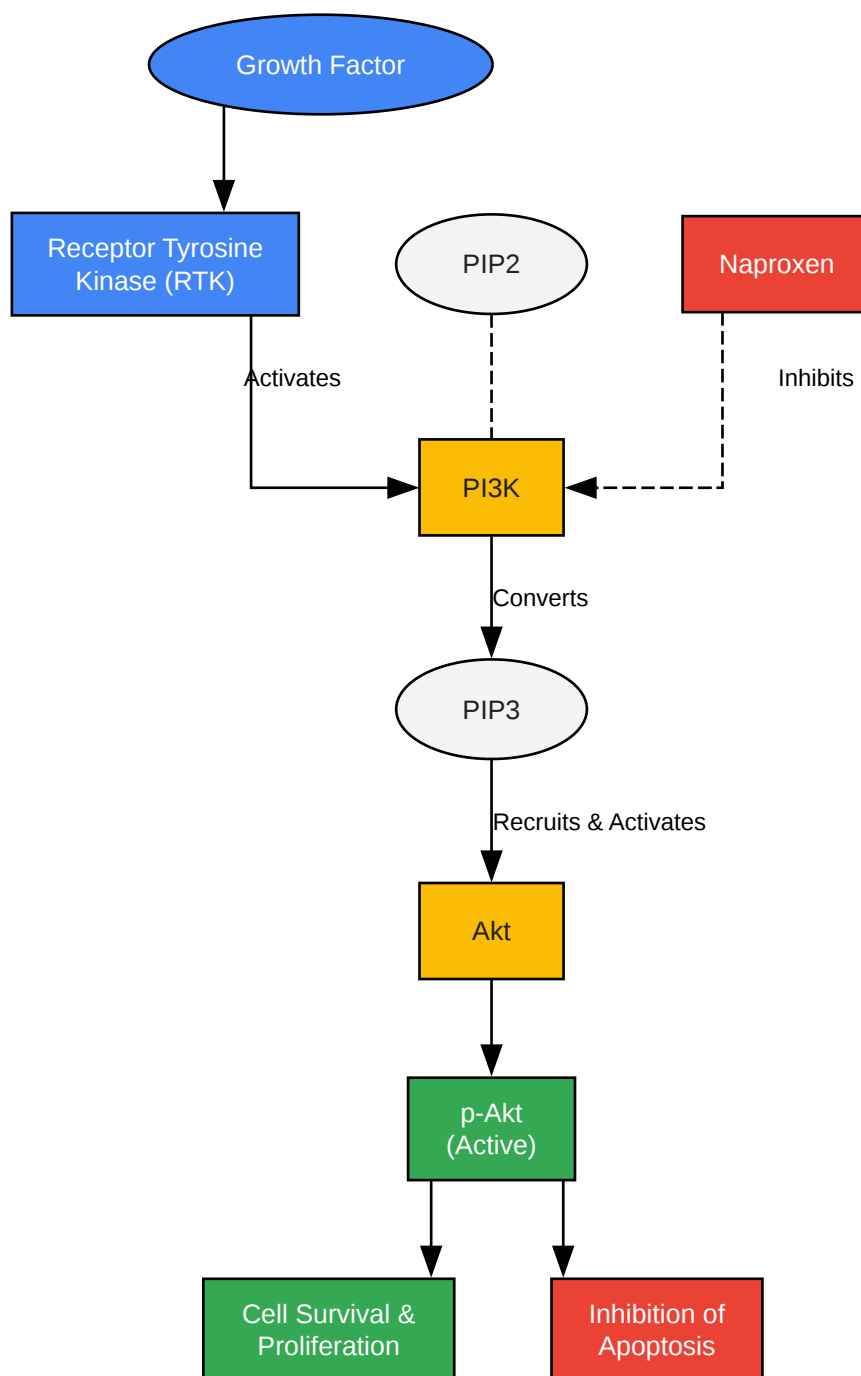

[Click to download full resolution via product page](#)

Need Custom Synthesis?

BenchChem offers custom synthesis for rare earth carbides and specific isotopic labeling.

Email: info@benchchem.com or [Request Quote Online](#).

References

- 1. youtube.com [youtube.com]
- 2. Repurposing of Indomethacin and Naproxen as anticancer agents: progress from 2017 to present - PMC [pmc.ncbi.nlm.nih.gov]
- 3. Naproxen induces cell cycle arrest and apoptosis in human urinary bladder cancer cell lines and chemically induced cancers by targeting PI3-K - PMC [pmc.ncbi.nlm.nih.gov]
- 4. Naproxen induces cell-cycle arrest and apoptosis in human urinary bladder cancer cell lines and chemically induced cancers by targeting PI3K - PubMed [pubmed.ncbi.nlm.nih.gov]
- 5. pubcompare.ai [pubcompare.ai]
- 6. open.metu.edu.tr [open.metu.edu.tr]
- 7. biorxiv.org [biorxiv.org]
- 8. A novel naproxen derivative capable of displaying anti-cancer and anti-migratory properties against human breast cancer cells - PMC [pmc.ncbi.nlm.nih.gov]
- 9. reddit.com [reddit.com]
- 10. MTT assay overview | Abcam [abcam.com]
- 11. Flow cytometric analysis of P-glycoprotein function using rhodamine 123 - PubMed [pubmed.ncbi.nlm.nih.gov]
- 12. The detection of rhodamine 123 efflux at low levels of drug resistance - PubMed [pubmed.ncbi.nlm.nih.gov]
- To cite this document: BenchChem. [Technical Support Center: Overcoming Resistance to Naproxen Sodium in Cell Lines]. BenchChem, [2025]. [Online PDF]. Available at: [https://www.benchchem.com/product/b1262176#overcoming-resistance-to-naproxen-sodium-in-cell-lines]

Disclaimer & Data Validity:

The information provided in this document is for Research Use Only (RUO) and is strictly not intended for diagnostic or therapeutic procedures. While BenchChem strives to provide accurate protocols, we make no warranties, express or implied, regarding the fitness of this product for every specific experimental setup.

Technical Support: The protocols provided are for reference purposes. Unsure if this reagent suits your experiment? [[Contact our Ph.D. Support Team for a compatibility check](#)]

Need Industrial/Bulk Grade? [Request Custom Synthesis Quote](#)

BenchChem

Our mission is to be the trusted global source of essential and advanced chemicals, empowering scientists and researchers to drive progress in science and industry.

Contact

Address: 3281 E Guasti Rd

Ontario, CA 91761, United States

Phone: (601) 213-4426

Email: info@benchchem.com